

# SEAC<sup>®</sup>

sea is calling

[www.seacsub.com](http://www.seacsub.com)



scuba | snorkeling | freediving | 2020



**seac**<sup>®</sup>  
sea is calling



### Passion fast forward

SEAC® SUB has been a leading dive company since 1971. Founded by **Marco Arata** and **Attilio Rapallini**, our company has grown since then in size, strength, and innovation to become a benchmark in the industry. With the arrival of Marco's son **Daniele Arata**, we strategically reorganized the company, expanding our product lines and repositioning our brand image, bringing us to the forefront while continuing to honor our founding principles.

### Internal R&D department

In order to continuously improve our products and deliver our famous high quality, at SEAC® we have an **internal R&D department**. Our designers boast extensive expertise in the sector and work with some of the most advanced design and development systems in existence. Our staff supports every phase of our industrial design with help from expert consultants who also have vast experience in the diving sector. Products are of the finest quality only insofar as the materials used to make them are equally exceptional. That's why our company produces the components for our products using materials like rubber, liquid silicone, and technopolymers. What's more, our fins, masks, and snorkels are manufactured in modern facilities under the careful eye of staff with long-standing experience.

### In-house manufacture of regulators

SEAC® regulators are designed, developed, and manufactured entirely in Italy in our own internal departments. Our regulators department is equipped with **the most advanced calibration and testing devices available**. Every regulator undergoes test bench testing, calibration, and inspection. Our lab has two ANSTI machines for dynamic control, and dive simulations are performed under the most real and extreme conditions, measuring and recording parameters and breathing effort as dictated by European Regulations.

### Internal moulding

From October 2019, SEAC® will inaugurate a department completely dedicated to plastic moulding in its main location in San Colombano Certenoli. This innovative and ambitious project demonstrates **the company's continuous growth** and constant focus on a market that values quality. A new team of technicians specialized in industrial plastic moulding and printing will ensure excellent production capacity and high quality standards that will confirm the added value of the Made in Italy brand.

### Manufacture of spearguns

Spearfishing guns are one of SEAC's true points of excellence. With **more than forty years of experience and a daily passion** for underwater spearfishing are two of the greatest guarantees that we can offer our customers. Our careful focus on production and quality controls on both materials and finished products - including the ballistic testing our products undergo - allows us to offer a range of accurate, high quality weapons that meet the needs of even the most demanding spearfishermen.

### Slings made of 100% natural latex

SEAC® speargun slings are manufactured using **the best latex tubes** on the market, and every batch must pass the most stringent of testing. We test our slings with dynamometric and accelerated aging equipment to ensure the correct consistency in quality. The slings are assembled using special hydraulic equipment designed specifically for this purpose.

### Logistics and shipping

Building on the changes we made in response to new challenges and a constantly evolving market, in 2014 we revised and reorganized our logistical and production departments and further expanded them in 2019. We brought new technologies and new management systems online to make our shipping and supply department work better and more efficiently as we continue to serve the entire world. Our high standards and **advanced production and orders management** criteria can satisfy every customer.

### Pasión por un avance rápido

SEAC® SUB ha sido una empresa líder en buceo desde 1971. Fundada por **Marco Arata y Attilio Rapallini**, nuestra empresa desde entonces ha crecido en tamaño, solidez e innovación, hasta llegar a convertirse en una marca de referencia dentro del sector. Con la llegada del hijo de Marco, **Daniele Arata**, llegó también la reorganización estratégica de la empresa, que se dirigió a ampliar nuestras líneas de productos y reposicionar nuestra imagen de marca, lo cual nos ha colocado hoy en día a la primera línea de vanguardia al tiempo que seguimos haciendo honor a nuestros principios fundacionales.

### Departamento interno de I+D

Con el fin de ofrecer una mejora continuada de nuestros productos junto con nuestra famosa garantía de alta calidad, en SEAC® disponemos de nuestro **departamento interno de I+D**. Nuestros diseñadores gozan de una amplísima experiencia en el sector y trabajan con algunos de los sistemas de diseño y de desarrollo más avanzados que existen. Nuestro personal resigue cada una de las fases de nuestros diseños industriales mediante la ayuda de consultores expertos, los cuales vienen respaldados también por una amplia experiencia en el sector del buceo. No obstante, nuestros productos son resultado de la mejor calidad por el simple hecho de que los materiales que utilizamos son de una calidad igualmente excepcional. Este es el motivo por el que nuestra empresa produce los componentes para nuestros productos usando materiales como caucho, silicona líquida y tecnopolímeros. Y lo que es más, tanto aletas, máscaras como boquillas, todo ello se fabrica en nuestras modernas instalaciones bajo la supervisión minuciosa de equipos con una larga experiencia y trayectoria.

### Fabricación interna de reguladores

Los reguladores SEAC® se diseñan, desarrollan y fabrican por entero en Italia, en nuestros propios departamentos internos. Nuestro departamento de reguladores está equipado con los **dispositivos de calibración y pruebas más avanzados**. Todos los reguladores se someten a un proceso de pruebas, calibración e inspección que son de referencia en el sector. En nuestro laboratorio disponemos de dos máquinas ANSTI de control dinámico, y las simulaciones de buceo se llevan a cabo bajo condiciones que son altamente reales y extremas, midiendo y registrando los parámetros y esfuerzos de respiración de acuerdo con los dictámenes aprobados por las regulaciones europeas.

### Estampación interna

Desde octubre de 2019 SEAC® inaugurará un nuevo departamento totalmente dedicado a la estampación plástica en su sede central de San Colombano Certenoli (Génova). Un proyecto innovador y ambicioso que da fe del **constante crecimiento de la empresa** y de su gran atención a un mercado en el que se premia la calidad. Un nuevo equipo de técnicos especializados en la estampación y elaboración plástica industrial garantizará una gran capacidad productiva y altos estándares cualitativos para que el "Made in Italy" se convierta en un auténtico valor añadido.

### La fabricación de fusiles de pesca submarina

Los fusiles de pesca submarina son uno de los verdaderos puntos de excelencia de SEAC. Nuestros **más de cuarenta años de experiencia y una pasión diaria** por la pesca submarina son dos de las mejores garantías que ofrecemos a nuestros clientes. Nuestro cuidadoso foco de atención puesto en la producción y los controles de calidad tanto de materiales como de los productos acabados —incluidas las pruebas de balística que pasan nuestros productos— nos permite ofrecer una gama de armas precisas y de alta calidad que satisfacen las necesidades de los pescadores más exigentes.

### Gomas fabricadas en 100 % látex natural

Las gomas para fusiles de SEAC® se fabrican a partir de **los mejores tubos de látex** que existen en el mercado, y se requiere que cada lote supere las pruebas de calidad necesarias. Probamos nuestras gomas mediante un equipo dinamométrico y de envejecimiento acelerado para asegurar una consistencia adecuada en su calidad. Las gomas se montan usando un equipo hidráulico especial diseñado específicamente para este propósito.

### Logística y transporte

Creciendo a partir de los cambios que hemos ido incorporando para dar respuesta a nuevos retos y a un mercado en evolución constante, en 2014 llegó el momento de revisar y reorganizar nuestros departamentos de logística y producción y los expandió aún más en 2019. Esto nos ha llevado a trasladar todas nuestras nuevas tecnologías y sistemas nuevos de gestión a un ámbito digitalizado y en línea, de modo que nuestro departamento de envíos y suministros pueda gozar de una operativa mejorada y más eficaz, al mismo tiempo que seguimos ofreciendo nuestros productos en todo el mundo. Nuestros altos estándares y criterios de **producción avanzada y gestión de pedidos** nos permiten satisfacer a todos nuestros clientes.





**seac**<sup>®</sup>  
sea is calling





SCUBA	
COMPUTERS AND GAUGES   ORDENADORES E INSTRUMENTOS	6
REGULATORS   REGULADORES	12
BCDS   BCD	27
TORCHES   LINTERNAS	36
DIVING SUITS   TRAJES DE BUCEO	43
FINS   ALETAS	63
MASKS AND SNORKELS   MÁSCARAS Y ESNÓRQUELES	69
KNIVES   CUCHILLOS	83
BAGS AND ACCESSORIES   BOLSAS Y ACCESORIOS	90
SNORKELING	
FULL-FACE MASKS   MÁSCARAS COMPLETAS	99
MASKS AND SNORKELS   MÁSCARAS Y ESNÓRQUELES	106
FINS   ALETAS	125
SNORKELING SET   CONJUNTO DE ESNÓRQUEL	130
RASH GUARD	142
ACCESSORIES   ACCESORIOS	147
FREEDIVING	
COMPUTERS   ORDENADOR	156
WETSUITS   TRAJES HÚMEDOS	161
SPEARGUNS   FUSILES	174
FINS   ALETAS	193
MASKS AND SNORKELS   MÁSCARAS Y ESNÓRQUELES	198
TORCHES AND KNIVES   LINTERNAS Y CUCHILLOS	206
BAGS AND ACCESSORIES   BOLSAS Y ACCESORIOS	213
MERCHANDISING   ARTÍCULOS PUBLICITARIOS	223
PARTNERSHIP	230

© PHOTO CREDITS | CRÉDITOS DE LAS FOTOS  
 Stefano D'Urso & Santo Acciaro - Francesca Cambi  
 Massimo Prampi - Renata Romeo

GRAPHIC DESIGN | DISEÑO GRÁFICO  
 SEAC® Advertising Department







# Computers and gauges | Ordenadores e instrumentos

SEAC® dive computers and consoles are designed to guarantee the maximum data accuracy, without compromising on style and functionality.

Our focus on safety combines with our research into perfect ergonomics and making our products as easy as possible to use. This results in a line of instruments that enables you to consistently monitor your dive profile clearly and precisely.

Los ordenadores de buceo y consolas SEAC® están diseñados para garantizar la precisión máxima de los datos, sin comprometer el estilo y la funcionalidad. Combinamos nuestra atención a la seguridad con nuestra investigación para lograr la ergonomía perfecta y obtener productos fáciles de utilizar. Esto da como resultado una línea de instrumentos que le permiten monitorear constantemente su perfil de inmersión, con claridad y precisión.





# ACTION HR

## HIGH RESISTANCE

ITALIAN DESIGN



48.8 mm



38.4 mm



OS / WINDOWS COMPATIBLE



100 METERS



VERSION   VERSIÓN	HR
 BLACK/RED	160-6NR
 BLACK	160-6N



- SEAC® ACTION and SEAC® ACTION HR are new wrist-mount diving computers for scuba and freediving. Easy to use, with 3 main modes:
- SCUBA MODE: full management of recreational dive profiles with a Bühlmann ZHL-16C decompression algorithm for 1 or 2 mixes (air, Nitrox, and mixes with O<sub>2</sub> concentrations up to 99%).
- GAUGE MODE: Depth gauge and stopwatch for managing your dive profiles independently.
- FREEDIVING MODE: Dive/surface time, current/maximum depth.
- LOGBOOK MEMORY: SCUBA mode: 40 hours with records every 5'. FREEDIVING mode: 18 hours of activity with records every 2'.
- Safety warning: MOD exceeded alarm, deco stop violated alarm, ascent speed alarm, NoFly time and desaturation calculations, maximum permitted altitude warning.
- "NDL only" Dive Planner.
- Dive Manager software for MAC/PC (requires Windows 10), available free of charge at seacsub.com.
- Download data via USB cable (optional accessory).
- Ultra-durable structure treated for improved resistance to blows, corrosion, and swings in temperature.
- LCD screen with contrast and adjustable-intensity backlighting.
- Long-lasting CR2450 battery.
- Available in version with crown, buttons, and buckle in stainless steel (ACTION) or with HR treatment (ACTION HR).

## ACTION

 ITALIAN DESIGN

NEW



scuba | 2020



VERSION   VERSIÓN	INOX
■ BLACK	160-5N
■ BLACK/WHITE	160-5NW

- SEAC® ACTION y SEAC® ACTION HR son los nuevos ordenadores de muñeca para submarinismo y apnea. Muy fáciles de usar, con 3 modalidades principales:
- Modo SCUBA: gestión completa de los perfiles de inmersión recreativa con algoritmo de descompresión Bühlmann ZHL-16C para 1 o 2 mezclas (aire, Nitrox y mezclas con concentración de O<sub>2</sub> hasta el 99 %).
- Modo GAUGE: profundímetro y cronómetro para la gestión en autonomía de los perfiles de inmersión.
- Modo FREEDIVING: tiempo de inmersión/superficie, profundidad actual/máxima.
- MEMORIA DEL DIARIO DE INMERSIONES: Modo SCUBA: 40 horas con registros cada 5". Modo FREEDIVING: 18 horas de actividad con registros cada 2".
- Avisos de seguridad: alarma de superación de la MOD, alarma de violación de la parada de descompresión, alarma de velocidad de ascenso, cálculo del tiempo de prohibición de vuelo y desaturación, aviso de altitud máxima permitida.
- Planificador de inmersiones "solo NDL".
- Software de gestión de las inmersiones para MAC/PC (requiere Windows 10) disponible gratuitamente en seacsub.com.
- Descarga de datos con cable USB (disponible como extra).
- Estructura extremadamente sólida y tratada para una mayor resistencia a los golpes, la corrosión y las oscilaciones térmicas.
- Pantalla LCD con contraste y retroiluminación con intensidad regulable.
- Pila CR2450 de larga duración.
- Disponible en versión con corona, botones y hebilla de acero inoxidable (ACTION) o con tratamiento HR (ACTION HR).







ACTION

ACTION HR



COD. 163-21



VERSION   VERSIÓN	BUCKLE   HEBILLA: INOX	BUCKLE   HEBILLA: HR
 BLACK/RED	-	163-22NR
 BLACK/WHITE	163-20NW	-
 BLACK	163-20N	163-22N

**COMPACT PRESSURE GAUGE | MANÓMETRO COMPACT**

 MADE IN ITALY

- Case: molded brass, chrome-plated exterior.
- Hose: 800 mm high-performance HP.
- Glass: high-performance polycarbonate
- Face: luminescent.
- Scale: 0-400 BAR (10 BAR increments).
- Carcasa: latón moldeado, exterior cromado.
- Latiguillo: HP de alto rendimiento, 800 mm.
- Vidrio: policarbonato de alto rendimiento.
- Cuadrante: luminiscente.
- Escala: 0-400 BAR (incrementos de 10 BAR).

UNITS   UNIDADES	BAR	PSI
COD.	60-1	60-1/PSI

**CONSOLLE 2**

 MADE IN ITALY

- Depth gauge.
- Internal system: Bourdon gauge in oil bath.
- Face: luminescent.
- Scale: 0-70 m (1 m increments).
- Profundímetro.
- Sistema interno: manómetro de Bourdon en baño de aceite.
- Cuadrante: luminiscente.
- Escala: 0-70 m (incrementos de 1 m).

UNITS   UNIDADES	BAR/M	PSI/FT
COD.	60-11	60-11/PSI+FT

**CONSOLLE 3**

 MADE IN ITALY

Includes pressure gauge, depth gauge and Compass.  
 Incluye el manómetro de presión, profundímetro y brújula.

UNITS   UNIDADES	BAR/M	PSI/FT
COD.	60-12	60-12/PSI+FT

**WRIST COMPASS | BRÚJULA DE MUÑECA**

 MADE IN ITALY

- Case: high-performance ABS.
- Glass: High-performance polycarbonate.
- Face: luminescent.
- Scale: 0-360° (10 degree increments).
- Vidrio: ABS de alto rendimiento.
- Cristal: policarbonato de alto rendimiento.
- Cuadrante: luminiscente.
- Escala: 0-360° (incrementos en 10 grados).



COD. 60-13

**HP HOSE + SWIVEL | LATIGUILLO HP + CONEXIÓN GIRATORIA**

 MADE IN ITALY

Universal pressure gauge hose with swivel.

Latiguillo universal para manómetro con swivel.



VERSION   VERSIÓN	HP 80 cm	SWIVEL
COD.	S125001	S125004







# Regulators | Reguladores

SEAC® regulators are made using some of the most reliable and precise production methods.

This is why our company has made sizable investments in the design and internal manufacture of its regulators.

Assembled, calibrated, and tested one by one, they undergo a series of quality control phases to certify them even under the most recent CE EN 250 standards. Safety in the water, first and foremost.

Los reguladores SEAC® SUB se fabrican a partir de algunos de los métodos de producción más fiables y precisos que existen. Esta es la razón por la que nuestra empresa ha realizado importantes inversiones en el diseño y la fabricación interna de nuestros reguladores. Ensamblados, calibrados y probados uno a uno, todos nuestros reguladores pasan por diversas fases de control de calidad a fin de obtener su certificación incluso bajo los estándares de aplicación más recientes CE EN 250. Lo primero y fundamental es la seguridad en el agua.





**DX200 ICE DIN 300 BAR**

MADE IN ITALY

**DX200 ICE INT 230 BAR**

MADE IN ITALY

**First Stage:**

- Made of Sand-blasted forged brass.
- High-performance balanced diaphragm design: The Intermediate Pressure is always constant during the dive at any depth.
- ICE Kit: fully isolates all moving parts from contact with the water, ensuring excellent thermal protection in cold water.
- Simple and fast maintenance.
- HP ports: 2
- LP ports: 4
- Replaceable stainless-steel Valve Seat: designed to offer great safety, it can be easily disassembled to make maintenance easy.

**Second Stage:**

- Made of technopolimers, elastomers, and metal componets.
- Front cover enhanced with rust-proofing and scratch-resistant Luxury Technology treatment.
- Adjustable breathing effort and Venturi effect.
- OWS System: the Cover is designed to prevent free flow even in strong currents.

**Primera etapa:**

- Hecha de latón forjado y arenado.
- Diseño de diafragma compensado de alto rendimiento: La presión intermedia siempre es constante durante la inmersión, a cualquier profundidad.
- Kit Ice: aísla completamente todas las piezas en movimiento del contacto con el agua, garantizando una excelente protección térmica en aguas frías.
- Mantenimiento simple y rápido
- Puertos HP (alta presión): 2
- Puertos LP (baja presión): 4
- Asiento de la válvula de acero inoxidable, reemplazable: diseñado para ofrecer mucha seguridad, se puede desmontar fácilmente para que el mantenimiento sea sencillo.

**Segunda etapa:**

- Hecha de tecnopolímeros, elastómeros y componentes de metal.
- Cubierta frontal enriquecida con tratamiento anticorrosión y antiarañazos Luxury Technology.
- Permite ajustar el esfuerzo respiratorio y el efecto Venturi.
- Sistema OWS: la cubierta está diseñada para evitar el flujo libre, aun en corrientes fuertes.

REGULATORS REGULADORES	ICE DIN 300 BAR	ICE INT 230 BAR
COD.	35-72/I300D	35-72/I230I
WEIGHT   PESO (g)	1059	1210



1 <sup>ST</sup> STAGE 1ª ETAPA	ICE DIN 300 BAR	ICE INT 230 BAR
COD.	35-75/I300D	35-75/I230I
WEIGHT   PESO (g)	665	827

2 <sup>ND</sup> STAGE 2ª ETAPA	
COD.	35-78
WEIGHT   PESO (g)	210

Breathing effort at 50 msw and 50 bar: 0.63 J/l.  
Esfuerzo de respiración a 50 msw y 50 bares: 0,63 J/l.

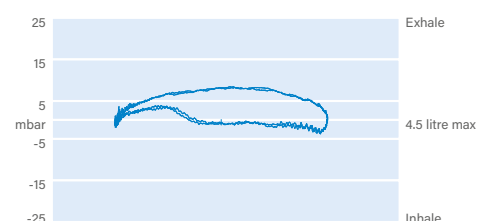

## SET DX200 ICE DIN 300 BAR

MADE IN ITALY



## SET DX200 ICE INT 230 BAR

MADE IN ITALY



Set including DX200 ICE regulator and X100 OCTO.  
Mate Reg bag included.

Este conjunto incluye el regulador DX200 ICE y el octopus X100.  
Incluye bolsa para regulador Mate.



VERSION   VERSIÓN	300 DIN	230 INT
COD.	35-90/I300D	35-90/I230I
WEIGHT   PESO (g)	1422	1586

## DX200 DIN 300 BAR

MADE IN ITALY



## DX200 INT 230 BAR

MADE IN ITALY



**First Stage:**

- Made from Sand-blasted forged brass.
- High-performance balanced diaphragm design: The Intermediate Pressure is always constant during the dive at any depth.
- Simple and fast maintenance.
- HP ports: 2
- LP ports: 4
- Replaceable stainless-steel Valve Seat: designed to offer great safety, it can be easily disassembled to make maintenance easy.

**Second Stage:**

- Made of technopolimers, elastomers, and metal componets.
- Front cover enhanced with rust-proofing and scratch-resistant Luxury Technology treatment.
- Adjustable breathing effort and Venturi effect.
- OWS System: the Cover is designed to prevent free flow even in strong currents.

**Primera etapa**

- Hecha de latón forjado y arenado.
- Diseño de diafragma compensado de alto rendimiento: La presión intermedia siempre es constante durante la inmersión, a cualquier profundidad.
- Mantenimiento simple y rápido
- Puertos HP (alta presión): 2
- Puertos LP (baja presión): 4
- Asiento de la válvula de acero inoxidable, reemplazable: diseñado para ofrecer mucha seguridad, se puede desmontar fácilmente para que el mantenimiento sea sencillo.

**Segunda etapa:**

- Hecha de tecnopolímeros, elastómeros y componentes de metal.
- Cubierta frontal enriquecida con tratamiento anticorrosión y antiarañazos Luxury Technology.
- Permite ajustar el esfuerzo respiratorio y el efecto Venturi.
- Sistema OWS: la cubierta está diseñada para evitar el flujo libre, aun en corrientes fuertes.

REGULATORS REGULADORES	DIN 300 BAR	INT 230 BAR
COD.	35-72/300D	35-72/230I
WEIGHT   PESO (g)	990	1140



1 <sup>ST</sup> STAGE 1ª ETAPA	DIN 300 BAR	INT 230 BAR
COD.	35-75/300D	35-75/230I
WEIGHT   PESO (g)	576	747

2 <sup>ND</sup> STAGE 2ª ETAPA	
COD.	35-78
WEIGHT   PESO (g)	210

Breathing effort at 50 msw and 50 bar: 0.63 J/l.  
Esfuerzo de respiración a 50 msw y 50 bares: 0,63 J/l.

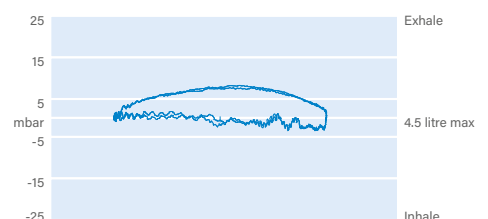

## SET DX200 DIN 300 BAR

MADE IN ITALY



## SET DX200 INT 230 BAR

MADE IN ITALY



Set including DX200 regulator and X100 OCTO, available in DIN and INT Version. Mate Reg bag included.

Este conjunto incluye el regulador DX200 y el OCTO X100, disponible en la versión tanto DIN como INT. Incluye bolsa para regulador Mate.



VERSION   VERSIÓN	DIN 300 BAR	INT 230 BAR
COD.	35-90/300D	35-90/230I
WEIGHT   PESO (g)	1353	1503



## MX100 DIN 300 BAR

MADE IN ITALY



## MX100 INT 230 BAR

MADE IN ITALY



**First Stage:**

- Made from chrome-plated polished brass.
- High-performance balanced diaphragm design: The Intermediate Pressure is always constant during the dive at any depth.
- Intermediate Pressure can easily adjusted.
- Simple and fast maintenance.
- HP ports: 2; LP ports: 4
- Replaceable stainless-steel Valve Seat: designed to offer great safety, it can be easily disassembled to make maintenance easy .

**Second Stage:**

- made by technopolimers, elastomers, and metal componets.
- Front cover enhanced with rust-proofing and scratch-resistant Luxury Technology treatment.
- Adjustable Venturi effect (Dive/Pre Dive).
- New Lever: less friction makes breathing more natural.
- OWS System: the Cover is designed to prevent free flow even in strong currents.

**Primera etapa**

- Hecha de latón forjado y arenado.
- Diseño de diafragma compensado de alto rendimiento: La presión intermedia siempre es constante durante la inmersión, a cualquier profundidad.
- La presión intermedia se puede adaptar fácilmente.
- Mantenimiento simple y rápido
- Puertos HP (alta presión): 2 • Puertos LP (baja presión): 4
- Asiento de la válvula de acero inoxidable, reemplazable: diseñado para ofrecer mucha seguridad, se puede desmontar fácilmente para que el mantenimiento sea sencillo.

**Segunda etapa:**

- Hecha de tecnopolímeros, elastómeros y componentes de metal.
- Cubierta frontal enriquecida con tratamiento anticorrosión y antiarañazos Luxury Technology.
- Efecto Venturi ajustable (antes y durante la inmersión).
- Nueva palanca: la reducción en la fricción hace que sea más natural inhalar.
- Sistema OWS: la cubierta está diseñada para evitar el flujo libre, aun en corrientes fuertes.

REGULATORS REGULADORES	DIN 300 BAR	INT 230 BAR
COD.	35-71/300D	35-71/230I
WEIGHT   PESO (g)	940	1090



1 <sup>ST</sup> STAGE 1ª ETAPA	DIN 300 BAR	INT 230 BAR
COD.	35-76/300D	35-76/230I
WEIGHT   PESO (g)	596	796

2 <sup>ND</sup> STAGE 2ª ETAPA	
COD.	35-77
WEIGHT   PESO (g)	200

Breathing effort at 50 msw and 50 bar: 0.72 J/l.  
Esfuerzo de respiración a 50 msw y 50 bares: 0,72 J/l.

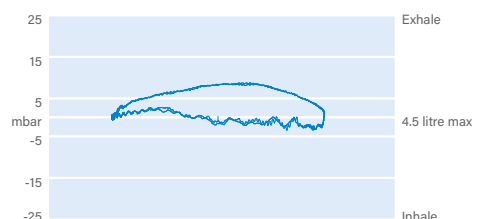

## SET MX100 DIN 300 BAR

MADE IN ITALY



## SET MX100 DIN/INT 230 BAR

MADE IN ITALY



Set including MX100 regulator and X100 OCTO, available in DIN and INT Version. Mate Reg bag included.

Este conjunto incluye el regulador MX100 y el X100 OCTO, disponible en la versión tanto DIN como INT. Incluye bolsa para regulador Mate.



VERSION   VERSIÓN	DIN 300 BAR	DIN 230 BAR	INT 230 BAR
COD.	35-89/300D	35-89/230D	35-89/230I
PESO   WEIGHT (g)	959	1000	1159

## P-SYNCHRO DIN 230 BAR

MADE IN ITALY



## P-SYNCHRO INT 230 BAR

MADE IN ITALY



**First stage:**

- made by Sand-blasted forged brass.
- Compensated Piston.
- Maintenance is simple and fast.
- HP ports: 1
- LP ports: 4
- Shockproof rubber cap.

**Second Stage:**

- made by ultralight technopolimers.
- Cover made in shockproof rubber.
- Adjustable Venturi effect (Dive/Pre Dive).
- Easy Purge System: the oversized purge button is easy to use.

**Primera etapa:**

- Hecha de latón forjado y arenado.
- Pistón no compensado.
- El mantenimiento es simple y rápido
- Puertos HP (alta presión): 1
- Puertos LP (baja presión): 4
- Capucha antigolpes de goma.

**Segunda etapa:**

- Hecha de tecnopolímeros ultra ligeros.
- Cubierta hecha de goma a prueba de golpes.
- Efecto Venturi ajustable (antes y durante la inmersión).
- Sistema Easy Purge: Botón de purga de grandes dimensiones y uso sencillo.

REGULATORS REGULADORES	DIN 230 BAR	INT 230 BAR
COD.	8401	8400
WEIGHT   PESO (g)	850	1040

1 <sup>ST</sup> STAGE 1ª ETAPA	DIN 230 BAR	INT 230 BAR
COD.	35-9/230D	35-9/230I
WEIGHT   PESO (g)	480	650

2 <sup>ND</sup> STAGE 2ª ETAPA	
COD.	8420
WEIGHT   PESO (g)	200



Breathing effort at 50 msw and 50 bar: 0,91 J/l.  
Esfuerzo de respiración a 50 msw y 50 bares: 0,91 J/l.

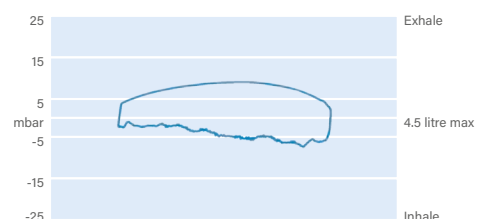

## SET P-SYNCHRO DIN 230 BAR

MADE IN ITALY



## SET P-SYNCHRO INT 230 BAR

MADE IN ITALY



- First stage body material: polished chrome-plated brass.
  - Second stage body material: ultralight technopolymers.
  - HP Ports: 1.
  - LP ports: 4.
  - First stage features: compensated piston.
  - Shockproof rubber cap on the first stage.
  - Option to regulate the Venturi effect (Dive/PreDive).
  - Functional Easy Purge System cap.
- Material de la primera etapa: latón pulido y cromado.
  - Material de la segunda etapa: tecnopolímeros ultralivianos.
  - Puertos HP (alta presión): 1.
  - Puertos LP (baja presión): 4.
  - Prestaciones de la primera etapa: pistón compensado.
  - Prestaciones de la primera etapa: fabricada usando tecnopolímeros ultraligeros, opción para regular el efecto Venturi.

VERSION   VERSIÓN	DIN 230 BAR	INT 230 BAR
COD.	35-28/230D	35-28/230I
WEIGHT   PESO (g)	1240	1430



## X100 OCTO

MADE IN ITALY



- Material: ultra light technopolymers and elastomers.
- 100 cm Hiflex hose.
- The lack of holes in the front cover prevents free flow even when facing strong currents (OWS System).
- Option to regulate the Venturi Effect (Dive/Pre Dive).
- Cap manufactured with corrosion and scratch-resistant Luxury Technology treatment.

- Material del X100 Octo: tecnopolímeros y elastómeros, y cubierta fabricada a partir de un tratamiento Luxury Technology resistente a la corrosión y al rayado.
- Latiguillo Hiflex de 100 cm.
- No presenta ningún tipo de orificio en la cubierta frontal, lo cual evita que se produzcan fugas de aire continuo incluso en situaciones de contracorrientes fuertes (sistema OWS).
- Opción para regular el esfuerzo el efecto Venturi (Dive/Pre Dive).

X100 OCTO		2 <sup>ND</sup> STAGE   2ª ETAPA	
COD.	35-74/O	COD.	35-79/O
WEIGHT   PESO (g)	363	WEIGHT   PESO (g)	180

## OCTO SYNCHRO

MADE IN ITALY



- Material: ultralight technopolymers.
- Option to regulate the Venturi Effect (Dive/Pre Dive).
- Functional Easy Purge System cap (Octo Synchro).

- Material del Octo Synchro: tecnopolímeros ultraligeros.
- Opción para regular el esfuerzo el efecto Venturi (Dive/Pre Dive).
- bierta funcional para sistema de purga fácil (Octo Synchro).

OCTO SYNCHRO		2 <sup>ND</sup> STAGE   2ª ETAPA	
COD.	8450	COD.	8470
WEIGHT   PESO (g)	390	WEIGHT   PESO (g)	200





# REGULATOR SERVICE KIT KIT DE SERVICIO DEL REGULADOR

Download the replacement part catalog:  
Descargue el catálogo de repuestos:



**D ICE 1<sup>ST</sup> STAGE**  
2 HP PORTS  
4 LP PORTS

**1<sup>ERA</sup> ETAPA D ICE**  
2 PUERTOS HP  
4 PUERTOS LP



SPARE PARTS   REPUESTOS	1 <sup>ST</sup> STAGE   1 <sup>A</sup> ETAPA DIN	1 <sup>ST</sup> STAGE   1 <sup>A</sup> ETAPA INT	2 <sup>ND</sup> STAGE   2 <sup>A</sup> ETAPA
COD.	5600008	5600006	5600002
DESCRIPTION DESCRIPCIÓN	D ICE Service kit Kit de servicio D ICE	D ICE Service kit Kit de servicio D ICE	X200 Service kit Kit de servicio X200

**D 1<sup>ST</sup> STAGE**  
2 HP PORTS  
4 LP PORTS

**1<sup>ERA</sup> ETAPA D**  
2 PUERTOS HP  
4 PUERTOS LP



SPARE PARTS   REPUESTOS	1 <sup>ST</sup> STAGE   1 <sup>A</sup> ETAPA DIN	1 <sup>ST</sup> STAGE   1 <sup>A</sup> ETAPA INT	2 <sup>ND</sup> STAGE   2 <sup>A</sup> ETAPA
COD.	5600007	5600005	5600002
DESCRIPTION DESCRIPCIÓN	D Service kit Kit de servicio D	D ICE Service kit Kit de servicio D ICE	X200 Service kit Kit de servicio X200

**M 1<sup>ST</sup> STAGE**  
2 HP PORTS  
4 LP PORTS

**1<sup>ERA</sup> ETAPA M**  
2 PUERTOS HP  
4 PUERTOS LP



SPARE PARTS   REPUESTOS	1 <sup>ST</sup> STAGE   1 <sup>A</sup> ETAPA DIN	1 <sup>ST</sup> STAGE   1 <sup>A</sup> ETAPA INT	2 <sup>ND</sup> STAGE   2 <sup>A</sup> ETAPA
COD.	5600003	5600004	5600001
DESCRIPTION DESCRIPCIÓN	M Service kit Kit de servicio M	M Service kit Kit de servicio M	X100 Service kit Kit de servicio X100

**P 1<sup>ST</sup> STAGE**  
1 HP PORT  
4 LP PORTS

**1<sup>ERA</sup> ETAPA P**  
1 PUERTO HP  
4 PUERTOS LP



SPARE PARTS   REPUESTOS	1 <sup>ST</sup> STAGE   1 <sup>A</sup> ETAPA DIN	1 <sup>ST</sup> STAGE   1 <sup>A</sup> ETAPA INT	2 <sup>ND</sup> STAGE   2 <sup>A</sup> ETAPA
COD.	8417	8412	8422
DESCRIPTION DESCRIPCIÓN	P-SYNCHRO/X-5 P Service kit Kit de servicio P-SYNCHRO/X-5 P	P-SYNCHRO/X-5 P Service kit Kit de servicio P-SYNCHRO/X-5 P	SYNCHRO Service kit Kit de servicio SYNCHRO

# TECHNICAL CHARACTERISTICS | CARACTERÍSTICAS TÉCNICAS

REGULATORS   REGULADORES	DX200	DX200 ICE	MX100	P-SYNCHRO
COMPENSATED PISTON PISTÓN COMPENSADO	-	-	-	✓
1 <sup>ST</sup> STAGE BALANCED MEMBRANE MEMBRANA COMPENSADA DE 1ª ETAPA	✓	✓	✓	-
ANTIFREEZE SYSTEM SISTEMA ANTICONGELANTE	-	✓	-	-
HP PORTS PUERTOS HP	2	2	2	1
LP PORTS PUERTOS LP	4	4	4	4
BALANCED 2 <sup>ND</sup> STAGE 2ª ETAPA COMPENSADA	✓	✓	-	-



## HIFLEX REGULATOR HOSE LATIGUILLO DE REGULADOR HIFLEX

MADE IN ITALY



- Standard: 780 mm black M 3/8"
- Octopus: 1000 mm yellow M 3/8"
- Estándar: 780 mm negro M 3/8"
- Octopus: 1000 mm amarillo M 3/8"

COD.	S812042	S812043
MODEL   MODELO	HIFLEX 78 CM	HIFLEX 100 CM

## HIFLEX REGULATOR HOSE LATIGUILLO DE REGULADOR HIFLEX

MADE IN ITALY



- Standard: 770 mm black M 3/8"
- Octopus: 1000 mm yellow M 3/8"
- Octopus: 2000 mm yellow M 3/8"
- Estándar: 770 mm negro M 3/8"
- Octopus: 1000 mm amarillo M 3/8"
- Octopus: 2000 mm amarillo M 3/8"

COD.	S812040	S812041	S800022
MODEL   MODELO	77 CM	100 CM	200 CM

# TANKS | BOTELLAS

MADE IN ITALY

- 34CRM04 Chromium-Molybdenum Alloy Steel.
- Manufacturing cycle from plate.
- Valves: single connection and double connection, chrome-plated satin-finished brass with DIN-INT connector with M25X2 thread pitch.
- External treatment: sand-blasting with fine grit, one 90-Micron protective zinc layer, 5 base layers of dual-component epoxy, 3 polyurethane finish layers, paint treated with "wet on wet" system, black and white segmenting on top in accordance with EC regulations.

- Acero a partir de la aleación de cromo-molibdeno 34CRM04.
- Ciclo de fabricación desde la placa.
- Válvulas: conexión sencilla y conexión doble, latón cromado con acabado satinado y conector DIN-INT con rosca M25X2.
- Tratamiento externo: arenado con grano fino, capa protectora de zinc de 90 micrones, 5 capas de base de epoxy de doble componente, 3 capas de acabado de poliuretano, pintura tratada con sistema «wet on wet», segmentación en blanco y negro, conforme a las regulaciones de EC.



COD.	65-12/M20	65-12/B20	65-15/M20	65-15/B20
LITER   LITROS	12	12	15	15
BAR	200	200	200	200
VALVE   VÁLVULA	M25X2 SINGLE CONNECTION CONEXIÓN SENCILLA	M25X2 DOUBLE CONNECTION CONEXIÓN DOBLE	M25X2 SINGLE CONNECTION CONEXIÓN SENCILLA	M25X2 DOUBLE CONNECTION CONEXIÓN DOBLE
DIAMETER   DIÁMETRO	180 mm	180 mm	200 mm	200 mm
HEIGHT   ALTURA	760 mm	760 mm	700 mm	700 mm

## MODULAR SINGLE CONNECTION VALVE VÁLVULA MODULAR DE CONEXIÓN ÚNICA

MADE IN ITALY



Modular single connection valves for tank.

- M25X2 thread.
- INT/DIN connector.

Válvulas de conexión sencilla para monobotella.

- Rosca M25X2.
- Conector INT/DIN.

COD. 67-25M

## MODULAR DOUBLE CONNECTION VALVE VÁLVULA MODULAR DE CONEXIÓN DUAL

MADE IN ITALY



Dual connection valves for single tank.

- M25X2 thread.
- INT/DIN connector.

Válvulas de conexión doble para monobotella.

- Rosca M25X2.
- Conector INT/DIN.

COD. 67-26B

## TANK HANDLE ASA TRANSPORTADORA PARA BOTELLA

MADE IN ITALY



Universal single-tank handle.

Asa transportadora universal para monobotella.

COD. 2081

## DIN/INT ADAPTOR ADAPTADOR DIN/INT

MADE IN ITALY



COD. S101028

## DIN PROTECTIVE CAP TAPA DE PROTECCIÓN PARA VÁLVULA DIN



Universal DIN first stage protective cap.

Tapa universal de protección para primera etapa con válvula DIN.

COD. 2011

**DIN/INT CONNECTOR  
CONECTOR DIN/INT**



DIN regulator to INT valve connector.  
Conector para válvula de regulador DIN a regulador INT.

COD. 2070

**HOSE GUARD  
PROTECCIÓN DE LATIGUILLO**



Universal hose guard.  
Protección universal para latiguillo.

COD. S060N

**REGULATOR MOUTHPIECE CLAMP  
CLIP DE SUJECIÓN PARA BOQUILLA DE REGULADOR**



COD. S500023

**REGULATOR MOUTHPIECE  
BOQUILLA DE REGULADOR**

Universal regulator mouthpiece.  
Boquilla universal de regulador.



COLOR	COD.
BLACK	236
TRANSPARENT	236/B

**ROUND OCTOPUS HOLDER  
SISTEMA DE SUJECIÓN REDONDO PARA OCTOPUS**

Round octopus holder.  
Clip de sujeción redondo para octopus.



COD. 2078

**TANK FASTENING STRAPS | CORREAS DE SUJECIÓN PARA BOTELLA**

MADE IN ITALY

Warning: two straps are needed to fasten the tank correctly.  
Advertencia: Se recomienda el uso necesario de 2 correas para una sujeción adecuada de la botella.

VERSION   VERSIÓN	SINGLE TANK (WITH NON-SLIP) MONOBOTELLA (CON ANTIDESLIZANTE)	DUAL TANK BIBOTELLA
COD.	S103004B	S103006



**TANK BOOT | BOTÍN DE BOTELLA**

MADE IN ITALY

Single tank Boot.  
Botín protector para monobotella.

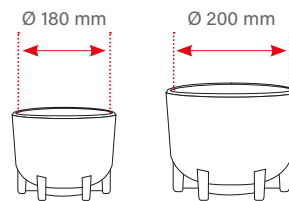

VERSION   VERSIÓN	SHORT   CORTA 7/10/12 L	LONG   LARGA 12/15/18 L
COD.	S101002	S101502

**TANK NET | RED DE PROTECCIÓN PARA BOTELLA**

MADE IN ITALY



LITER   LITROS	7	10	12 / LONG   LARGA	12 / SHORT   CORTA	15	18
COD.	701N	702N	703N	703/BN	704N	705N



## BCDs | BCD

SEAC® is known internationally for the high quality of our BCDs.

Sturdy, durable, and delivering excellent buoyancy lift, the BCDs we manufacture are the result of our technical and qualitative research into materials and cutting-edge new materials.

SEAC® es conocida internacionalmente por la alta calidad de sus BCD.

Robustos, resistentes y con unas propiedades de flotabilidad excelentes, los BCD que fabricamos no son más que el fruto de nuestras investigaciones técnicas y cualitativas tanto en materiales ya existentes como en los nuevos materiales de última generación.





# MODULAR MAX

MADE IN ITALY



NEW



Can accommodate different backplates and bags  
Mochila y bolsa reemplazables



harness separated from the inflatable side  
Arnés separado de la parte inflable

OPTIONAL



- SEAC® Modular Max is the evolution of Modular, SEAC's rear-volume recreational BCD designed for use with dual tanks.
- Donut bladder with 20 liters of thrust in durable 1680 Denari Ballistic Nylon outside and internal air chamber in polyurethane. Features a piston inflator and two quick discharge valves arranged to make it possible to dump quickly from any position.
- Freely customizable: every part of the SEAC® Modular Max BCD is interchangeable.
- You can simply and quickly adjust the structure of the BCD and find just the right buoyancy in any situation.
- Standard connections: the backpack for the SEAC® Modular Max BCD can accommodate different bladders and backpacks thanks to its standard-gauge eyelets for fastening using straps and other fasteners. The padding prevents any irritation from clamps in contact with the back.
- Convenient for travel: SEAC® Modular Max is the BCD that fits conveniently in your luggage, making it ideal for dive vacations.
- It disassembles quickly, takes up little space, and weighs just 3.1 kg, so you can use your own BCD, set to just how you need it, even when you travel.
- The standard equipment for the Modular Max includes: harness with removable shoulder straps and soft backpack with removable steel core, 20.0-liter dual donut bladder, 2 pockets with quick weight release, 4 anodized aluminum D-Rings, and belly buckle in stainless steel.

- SEAC® Modular Max es la evolución de Modular, el chaleco para inmersiones recreativas de volumen posterior de SEAC, diseñado para el uso de dos botellas.
- Bolsa anular de 20 litros de presión en resistente nailon balístico de 1680 deniers en el exterior y cámara de aire interna en poliuretano. Inflador de pistón y dos válvulas de descarga rápida dispuestas para permitir la descarga rápida en cualquier posición.
- A medida: cada pieza del chaleco SEAC® Modular Max es intercambiable.
- Es posible regular la estructura del chaleco de forma rápida y sencilla y encontrar el equilibrio perfecto en cualquier condición.
- Conexiones estándar: la espaldera del chaleco SEAC® Modular Max tiene cabida para bolsas y espalderas distintas gracias a los ojales de paso estándar para la fijación con correas y pernos. El acolchado evita las molestias de los ajustes al contacto con la espalda.
- Cómodo para viajar: SEAC® Modular Max es el chaleco que entra cómodamente en la maleta, ideal para vacaciones de buceo.
- Se desmonta rápidamente, ocupa poco espacio y solo pesa 3,1 kg, por lo que podrá utilizar su propio chaleco, ajustado a su medida, en sus viajes.
- Equipación base de Modular Max: arnés con tirantes extraíbles y espaldera blanda con núcleo de acero extraíble, bolsa doble anular de 20 l, 2 bolsillos de liberación rápida para lastre, 4 anillas en D de aluminio anodizado y hebilla abdominal de acero inoxidable.



## MODULAR MAX

COD.	42-39
SIZE   TALLA	ONE SIZE   TALLA ÚNICA
LIFT   ELEVACIÓN (kg)	20.0
LIFT   ELEVACIÓN (lb)	45
WEIGHT   PESO (kg)	3.1

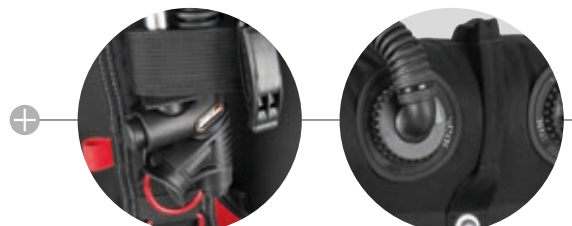

# MODULAR - MODULAR REV

MADE IN ITALY



UPGRADE

Can accommodate different backplates and bags  
Mochila y bolsa reemplazables



harness separated from the inflatable side  
Arnés separado de la parte inflable

OPTIONAL

Also available in REV version  
También disponible en versión REV

MODULAR

MODULAR REV



- Freedom, made to measure: every part of the SEAC® Modular BCD is interchangeable. You can simply and quickly adjust the structure of the BCD and find just the right buoyancy in any situation.
- Standard connections: the backpack for the SEAC® Modular BCD can accommodate different bags and backpacks thanks to its standard-gauge eyelets for fastening using straps and other fasteners. The padding prevents a irritation from clamps in contact with the back.
- Convenient for travel: SEAC® Modular is the BCD that fits conveniently in your luggage, making it ideal for dive vacations. It disassembles quickly, takes up little space, and weighs just 3kg, so you can use your own BCD set to just the right measurements even when you travel.
- Basic equipment: the basic SEAC® Modular equipment includes: harness with removable shoulder straps and soft backbone with removable steel core, a 13.5-liter donut double bladder, 2 quick-release pockets for weights, anodized aluminum D-rings and stainless steel belly buckle.

- SEAC® Modular es el nuevo chaleco de buceo con vejiga trasera de SEAC®, diseñado para los buceadores más exigentes que buscan un chaleco modular para usar en diversas aventuras submarinas. Comience por un arnés robusto con un núcleo de acero en una mochila blanda como base para personalizar su SEAC® Modular. Luego, puede agregar y reemplazar diversas partes del chaleco.
- Libertad a la medida de sus necesidades: cada parte del chaleco SEAC® Modular es intercambiable. Puede adaptar de manera sencilla y rápida la estructura del chaleco y encontrar la flotabilidad ideal para cada situación.
- Conexiones estándar: la mochila del chaleco de buceo SEAC® Modular puede adaptarse a diversas bolsas y mochilas, gracias a sus ojales estándar para ajustarlo usando tiras y correas. El acolchado evita la irritación a causa de las abrazaderas que están en contacto con la espalda.
- Cómodo para viajar: SEAC® Modular es un chaleco que entra perfectamente en su equipaje, por lo cual es ideal para disfrutar de unas vacaciones de buceo. Se desarma rápidamente, ocupa poco espacio y pesa sólo 3 kg, por lo cual puede usar su propio chaleco de buceo adaptado a la medida correcta, incluso cuando viaja.
- Equipo básico: el equipo básico de SEAC® Modular incluye: arnés con correas para los hombros desmontables y estructura blanda con núcleo de acero desmontable, una vejiga en forma de Donut doble con capacidad para 13,5 litros, 2 bolsillos de zafado rápido para lastre, anillo D y hebilla en la zona del vientre hecha de aluminio anodizado.



+



MODULAR		MODULAR REV	
COD.	42-37	COD.	42-38
SIZE   TALLA	ONE SIZE   TALLA ÚNICA	SIZE   TALLA	ONE SIZE   TALLA ÚNICA
LIFT   ELEVACIÓN (kg)	13.6	LIFT   ELEVACIÓN (kg)	13.6
LIFT   ELEVACIÓN (lb)	30	LIFT   ELEVACIÓN (lb)	30
WEIGHT   PESO (kg)	3	WEIGHT   PESO (kg)	3

## EQ PRO

MADE IN ITALY



NEW



- Ultra-practical harness: quick and easy to put on. Simply fasten the flat center buckle and adjust the front straps and shoulder straps.
- "Frame to back" system: the adjustments for the shoulder straps start directly from the backpack. The BCD won't warp, so the weight stays distributed correctly.
- Independent bladder: The bladder in the SEAC® EQ-PRO "slides" along the harness completely independently. When inflated, the pocket area rests comfortably along your sides, so it won't squeeze your abdominal area.
- Functional, low-drag design: even more compact bladder and a contour designed to be more hydrodynamic. Handle inside the backpack, making it easy to transport.
- Excellent fit for men and women: 3D Mesh inserts wrap fully around the shoulder straps and prevent rubbing.
- Swivel buckles adapt the harness to the female body. Available in 5 sizes.

- Arnés ultra práctico: vestibilidad fácil y rápida. Basta con enganchar la hebilla plana central y regular las correas frontales y los tirantes.
- Sistema "frame to back": las correas que regulan los tirantes parten directamente de la espalda. El chaleco no sufre ninguna deformación y el peso queda distribuido correctamente.
- Bolsa independiente: la bolsa del chaleco SEAC® EQ-PRO recorre el arnés de forma completamente independiente. Cuando se infla, la zona de los bolsillos se apoya cómodamente sobre los costados sin comprimir la zona abdominal.
- Diseño hidrodinámico y funcional: bolsa todavía más compacta y líneas diseñadas para una mayor hidrodinámica. Asa en el interior de la espalda para facilitar el transporte.
- Alta vestibilidad para mujer y hombre: inserciones de Mesh3D que envuelven completamente los tirantes y evitan rozaduras.
- Hebillas basculantes que adaptan el arnés al cuerpo femenino. Disponible en 5 tallas.



SIZE   TALLA	XS	S	M	L	XL
COD.	42-40/XS	42-40/S	42-40/M	42-40/L	42-40/XL
LIFT   ELEVACIÓN (kg)	9.5	9.5	14.5	15.5	17.5
LIFT   ELEVACIÓN (lb)	20.9	20.9	31.9	34.1	38.5



## SMART

ITALIAN DESIGN



Traditional BCD in 1000D Cordura fabric, zip-closure pockets and Safety Release system for quickly releasing weights. Models with stainless steel rings and chest adjustment to two different positions.

- Bladder external material: PU-coated 1000D Cordura.
- Bladder internal material: PU-coated 500D Cordura.
- Dump valves: 3, with pull cord.
- "D" rings: Six 25-mm in stainless steel.
- Dry weight (size L): 3100 g (including hose).
- Integrated weight: safety release system.

BCD tradicional confeccionado en tejido de Cordura de 1000 D y que presenta unos bolsillos con cierre de cremallera y un sistema de zafado de seguridad que favorece un zafado del lastre más rápido. Modelos con anillas de acero inoxidable y regulación en el pecho en dos posiciones diferentes.

- Material exterior de la cámara: Cordura 1000D recubierto en PU.
- Material interior de la cámara: Cordura 500D recubierto en PU.
- Válvulas de vaciado: 3, con tira de cordón.
- Anillas en D: seis de 25 mm en acero inoxidable.
- Peso en seco (talla L): 3100 g (con tráquea incluida).
- Sistema de lastre integrado con zafado de seguridad



SIZE   TALLA	XXS	XS	S	M	L	XL
COD.	42-34/XXS	42-34/XS	42-34/S	42-34/M	42-34/L	42-34/XL
LIFT   ELEVACIÓN (kg)	9.7	9.7	11.3	15.4	17.4	18.4
LIFT   ELEVACIÓN (lb)	21.4	21.4	24.7	33.7	40.3	40.3

## EGO

MADE IN ITALY



Traditional BCD made entirely in 1000D Cordura, including the bladder, pockets, and shoulder pads. Stainless steel rings and slots for housing the Octopus or dive instruments. Model with chest adjustment to two different positions.

- Bladder external material: PU-coated 1000D Cordura.
- Bladder internal material: PU-coated 1000D Cordura.
- Dump valves: 3, with pull cord.
- "D" rings: Four 25-mm stainless steel.
- Dry weight (size L): 3200 g (including hose).

BCD tradicional fabricado íntegramente en Cordura de 1000 D, incluidos la cámara, bolsillos y el sistema de acolchado de los hombros. Incorpora unas anillas de acero inoxidable y unas ranuras que permiten fijar el octopus u otros instrumentos de buceo. Modelo que permite regularse en dos posiciones diferentes en la zona del pecho.

- Material exterior de la cámara: Cordura 1000D recubierto en PU.
- Material interior de la cámara: Cordura 1000D recubierto en PU.
- Válvulas de vaciado: 3, con tira de cordón.
- Anillas en D: cuatro de 25 mm en acero inoxidable.
- Peso en seco (talla L): 3200 g (con tráquea incluida).



SIZE   TALLA	XXXS	XXS	XS	S	M	L	XL
COD.	70/0	70/00	70/01	70/02	70/03	70/04	70/05
LIFT   ELEVACIÓN (kg)	9.7	9.7	10.2	11.2	15.3	17.3	18.3
LIFT   ELEVACIÓN (lb)	21.4	21.4	22.5	24.7	33.7	40.3	40.3

## CLUB

ITALIAN DESIGN



Traditional BCD made of 500D Cordura. Designed to be versatile, and suitable for schools and dive centers. The shoulder straps feature our exclusive Triple Adjustment system, which allows the buckle to move to three different heights within the same size.

- Bladder external material: PU-coated 500D Cordura.
- Bladder internal material: PU-coated 500D Cordura.
- Dump valves: 3, with pull cord.
- "D" rings: 4 in technopolymer.
- Dry weight (size L): 3100 g (including hose).

BCD tradicional hecho en Cordura 500 D. Diseñado para un uso versátil que resulta perfecto para centros y escuelas de buceo. Las correas del hombro incorporan nuestro sistema exclusivo de Triple Ajuste, el cual permite que la hebilla pueda ajustarse en tres posiciones diferentes dentro de la misma talla.

- Material exterior de la cámara: Cordura 500D recubierto en PU.
- Material interior de la cámara: Cordura 500D recubierto en PU.
- Válvulas de vaciado: 3, con tira de cordón.
- Anillas en D: 4 en tecnopolímero.
- Peso en seco (talla L): 3100 g (con tráquea incluida).



SIZE   TALLA	XXXS	XXS	XS	S	M	L	XL
COD.	42-36/XXXS	42-36/XXS	42-36/XS	42-36/S	42-36/M	42-36/L	42-36/XL
LIFT   ELEVACIÓN (kg)	9.7	9.7	10.2	11.2	15.3	17.3	18.3
LIFT   ELEVACIÓN (lb)	21.4	21.4	22.5	24.7	33.7	40.3	40.3

## RENTAL KIT CLUB



Dive package designed for diving centers and schools: includes a Club BCD and a P-Synchro regulator with Octopus. Balanced piston regulator first stage. Second stage in sturdy and lightweight technopolymers.

Equipo de buceo diseñado especialmente para centros y escuelas de buceo: incluye el modelo de chaleco hidrostático Club BCD y el regulador P-Synchro, junto con un octopus y una consola. La primera etapa del regulador presenta un pistón compensado, mientras que la segunda etapa se ha fabricado a partir de tecnopolímeros resistentes al tiempo que ligeros.



SIZE   TALLA	XXXS	XXS	XS	S	M	L	XL
COD. (INT)	165-3/XXXS	165-3/XXS	165-3/XS	165-3/S	165-3/M	165-3/L	165-3/XL
COD. (DIN)	165-4/XXXS	165-4/XXS	165-4/XS	165-4/S	165-4/M	165-4/L	165-4/XL
LIFT   ELEVACIÓN (kg)	9.7	9.7	10.2	11.2	15.3	17.3	18.3
LIFT   ELEVACIÓN (lb)	21.4	21.4	22.5	24.7	33.7	40.3	40.3

## Q&S POCKET BOLSILLO Q&S

MODULAR  
MODULAR MAX



Q&S (Quick&Safe) quick-release pocket for integrated weights up to 4 kg, and universal eyelets for fastening your BCD knife.

Bolsillo Q&S (rápido y seguro) para lastres integrados de hasta 4 kg de peso, y ojales universales para ajustar el cuchillo de su chaleco.

COD. 1900601

## TRIM POCKET BOLSILLO DE LASTRE

MODULAR  
MODULAR MAX



Trim pockets for weights up to 2 kg with a Velcro flap for quick release.

Bolsillos para lastres de hasta 2 kg con una solapa de Velcro para zafado rápido.

COD. 0480459

## WEIGHT/OBJECTS POCKET BOLSILLO MULTIPROPÓSITO

MODULAR  
MODULAR MAX



Multipurpose pocket for accessories and weights in 1680 Denari ballistic Nylon with zipper, universal eyelets for fastening your BCD knife, and Velcro flap for quick-release of weights (up to 4 kg).

Bolsillo multipropósito para accesorios y lastres hecho en nailon balístico de 1680 Denari con cremallera, ojales universales para ajustar el cuchillo de su chaleco y solapa de velcro para un zafado rápido de los lastres (hasta 4 kg).

COD. 0480464

## ALUMINUM BACKPLATE MOCHILA DE ALUMINIO

NEW

MODULAR  
MODULAR MAX

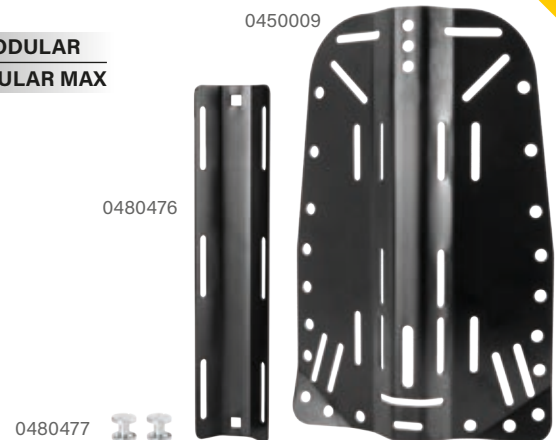

0480477

0480476

0450009

COD. 0480477

COD. 0480476

COD. 0450009

## ADDITIONAL WEIGHT POCKET BOLSILLO ADICIONAL PARA LASTRE



Rear weight pocket for fastening directly to the tank strap. Capacity up to 2 kg.

Bolsillo para lastre localizado en la parte posterior y que permite posicionarse directamente sobre la correa de la botella. Capacidad de hasta 2 kg.

COD. 763

## EQ WEIGHT POCKET BOLSILLOS PARA LASTRE EQ

NEW



Q&S (Quick&Safe) quick-release pocket for integrated weights up to 4 kg.

Bolsillos integrados de zafado rápido Q&S (rápido y seguro) para hasta 4 kg de peso.

COD. 0480478



## BCD HOSE LATIGUILLO PARA BCD



Male 3/8" 670 mm.

Conexión macho de 3/8" y 670 mm de largo.

COD. S55009

## ERGONOMIC HOSE RETAINER CLIP ERGONÓMICO PARA LATIGUILLO



Plastic hose retainer clip.

Clip de sujeción de plástico para latiguillo.

COD. S77458

## SINGLE METAL CLIP CLIP ÚNICO DE METAL

NEW



Stainless steel spiral cord  
1.3 m with metal carabiner.

Cordón en espiral de acero inoxidable  
con mosquetón de metal. (1,3 m)

COD. 111-105N

## DOPPIA CLIP METAL DOUBLE METAL CLIP

NEW



Stainless steel spiral cord 1.8 m  
with double metal carabiner.

Cordón en espiral de acero inoxidable con  
doble mosquetón de metal. (1,8 m)

COD. 111-104B

## DOUBLE HOOK CLIP CLIP CON DOS GANCHOS

Stainless steel spiral cord  
with double stainless steel  
carabiners and double  
fastening hook.



Cordón en espiral de acero inoxidable, que integra  
dos mosquetones también en acero inoxidable y un  
sistema de sujeción mediante dos ganchos.

COD. 2021

## DOUBLE CLIP SISTEMA DE DOBLE CLIP

Stainless steel spiral cord  
with double plastic carabiner.



Cordón en espiral de acero inoxidable  
con doble mosquetón de plástico.

COD. 2022

## SIMPLE RETRACTOR RETRACTOR SENCILLO



Stainless steel retractor cable.

Cable retractor sencillo.

COD. 2013

## LATEX ELASTIC RING CLIP CLIP CON ANILLA EN LÁTEX ELÁSTICA



Retaining carabiner for octopus with super elastic latex ring.

Mosquetón de sujeción para octopus con anilla  
de látex extraelástica.

COD. 2027

## TECHNICAL CHARACTERISTICS | CARACTERÍSTICAS TÉCNICAS

BCDs   BCD	MODULAR MAX	MODULAR	MODULAR REV
Q&S WEIGHT SYSTEM INTEGRATED WEIGHT SISTEMA DE LASTRE INTEGRADO CON ZAFADO Q&S	OPTIONAL	OPTIONAL	OPTIONAL
ADJUSTABLE HARNESS SYSTEM SISTEMA DE ARNÉS AJUSTABLE	✓	✓	✓
ADDITIONAL WEIGHT POCKET BOLSILLO ADICIONAL PARA LASTRE	20.0 kg 45 lb	13.6 kg 29.9 lb	13.6 kg 29.9 lb
WEIGHT PESO	3100 g	3000 g	3000 g

BCDs   BCD		SMART	EGO	CLUB	EQ PRO	
BUOYANCY LIFT CAPACIDAD DE ELEVACIÓN	XXXS	kg	-	7.2	-	
		lb	-	15.8	-	
	XXS	kg	-	7.2	7.2	-
		lb	-	15.8	15.8	-
	XS	kg	9.2	9.2	9.2	9.5
		lb	20.2	20.2	20.2	20.9
	S	kg	9.2	9.2	9.2	9.5
		lb	20.2	20.2	20.2	20.9
	M	kg	15.3	15.3	15.3	14.5
		lb	33.7	33.7	33.7	31.9
	L	kg	16.3	16.3	16.3	15.5
		lb	35.7	35.7	35.7	34.1
	XL	kg	18.3	18.3	18.3	17.5
		lb	40.3	40.3	40.3	38.5
XXL	kg	18.3	-	-	-	
	lb	40.3	-	-	-	
WEIGHT PESO	XXXS	g	-	-	-	
	XXS	g	-	-	-	
	XS	g	-	-	3200	
	S	g	-	-	3200	
	M	g	3900	2800	3900	
	L	g	4100	3000	4100	
	XL	g	4200	3000	4200	
	XXL	g	4300	3200	4300	
					-	









# Torches | Linternas

Sometimes getting around underwater can be complicated, especially when the light isn't perfect.

That's why SEAC® offers a full range of diving torches characterized by their increasingly innovative design that doesn't forget the influence of tradition and historic expertise. The very finest materials and highly functional precision components make SEAC® torches some of the most beloved with customers.

En ocasiones, desenvolvernors bajo el agua puede resultar complicado, especialmente cuando las condiciones de luz no son perfectas. Es por este motivo que SEAC® ofrece una gama completa de linternas de buceo caracterizadas por su diseño cada vez más innovador, el cual no olvida la influencia de la experiencia más tradicional y de siempre. Gracias a nuestros materiales de la mayor calidad y unos componentes de precisión altamente funcionales, las linternas SEAC® han pasado a ser uno de los productos más queridos por nuestros clientes.



## R40

Aluminum dive torch with tempered optical glass.

- Dimensions: diameter 62 mm - length 206 mm.
- Weight: 594 g.
- 3 CREE XPL LEDs.
- Battery: Li-Ion 26680 inside the torch, rechargeable via Micro-USB.
- Burn-time: 2 hours at max power - 5 hours at reduced power.
- Width of light beam: zoom adjustable, from 12° to 75°.
- On switch: electromagnetic system.
- Operating modes: max power, reduced power, flashing.
- Maximum operating depth: 100 mt.
- Light intensity: 2300 Lumens.
- Universal torch strap: included.
- Switch lock to prevent accidental ignition.

Linterna para buceo de aluminio con vidrio óptico templado.

- Dimensiones: diámetro 62 mm - longitud 206 mm.
- Peso: 594 gr.
- 3 LED CREE XPL.
- Batería: ion de litio 26680 en el interior de la linterna, recargable mediante cable micro USB.
- Horas de funcionamiento: 2 horas de luz máxima - 5 horas con energía reducida.
- Ancho del haz lumínico: zoom ajustable, de 12° a 75°.
- Botón de encendido: sistema electromagnético.
- Modos de funcionamiento: energía máxima, energía reducida, modo intermitente.
- Profundidad máxima de funcionamiento: 100 metros.
- Intensidad de la luz: 2300 lúmenes.
- Correa universal para linterna: incluida.
- Traba del botón para evitar encendido accidental.



OPTIONAL  
COD. 0530104



COD. 50-24/AN



2300 LUMEN



SWITCH LOCK

## R30

Aluminum dive torch with tempered optical glass.

- Dimensions: diameter 66 mm - length 170 mm.
- Weight: 480 g.
- 3 CREE XPG2 LEDs.
- Battery: Li-Ion 26650 inside the torch, rechargeable via Micro-USB.
- Burn-time: 2 hours at max power - 5 hours at reduced power.
- Width of light beam: zoom adjustable, from 12° to 75°.
- On switch: electromagnetic system.
- Operating modes: max power, reduced power, flashing.
- Maximum operating depth: 100 mt.
- Light intensity: 1500 Lumens.
- Universal torch strap: included.
- Switch lock to prevent accidental ignition.

Linterna para buceo de aluminio con vidrio óptico templado.

- Dimensiones: diámetro 66 mm - longitud 170 mm.
- Peso: 480 gr.
- 3 LED CREE XPG2.
- Batería: ion de litio 26650 en el interior de la linterna, recargable mediante cable micro USB.
- Horas de funcionamiento: 2 horas de luz máxima - 5 horas con energía reducida.
- Ancho del haz lumínico: zoom ajustable, de 12° a 75°.
- Botón de encendido: sistema electromagnético.
- Modos de funcionamiento: energía máxima, energía reducida, modo intermitente.
- Profundidad máxima de funcionamiento: 100 metros.
- Intensidad de la luz: 1500 lúmenes.
- Correa universal para linterna: incluida.
- Traba del botón para evitar encendido accidental.



OPTIONAL  
COD. 0530104



COD. 50-22/AN



1500 LUMEN



SWITCH LOCK





## R15

Aluminum dive torch with tempered optical glass.

- Dimensions: diameter 47 mm - length 166 mm.
- Weight: 300 g.
- 1 CREE XP-L LED.
- Battery: Li-Ion 18650 inside the torch, rechargeable via Micro-USB.
- Burn-time: 2 hours at max power - 4 hours at reduced power.
- Width of light beam: zoom adjustable, from 12° to 75°.
- On switch: electromagnetic system.
- Operating modes: light intensity adjustable using magnetic switch.
- Maximum operating depth: 100 mt.
- Light intensity: 900 Lumens.
- Universal torch strap: included.
- Switch lock to prevent accidental ignition.

- Linterna para buceo de aluminio con vidrio óptico templado.
- Dimensiones: diámetro 47 mm - longitud 166 mm.
- Peso: 300 gr.
- 1 LED CREE XP-L.
- Batería: ion de litio 18650 en el interior de la linterna, recargable mediante cable micro USB.
- Horas de funcionamiento: 2 horas de luz máxima - 4 horas con energía reducida.
- Ancho del haz lumínico: zoom ajustable, de 12° a 75°.
- Botón de encendido: sistema electromagnético.
- Modos de funcionamiento: intensidad de la luz ajustable usando el interruptor magnético.
- Profundidad máxima de funcionamiento: 100 m.
- Intensidad de la luz: 900 lúmenes.
- Correa universal para linterna: incluida.
- Traba del botón para evitar encendido accidental.



OPTIONAL  
COD. 0530104



COD. 50-25/AN



## R5

Aluminum dive torch with tempered optical glass.

- Dimensions: diameter 47 mm - length 166 mm.
- Weight: 300 g.
- 1 CREE XPG2 LED.
- Battery: Li-Ion 18650 inside the torch, rechargeable via Micro-USB.
- Burn-time: 2 hours at max power - 5 hours at reduced power.
- Width of light beam: zoom adjustable, from 12° to 75°.
- On switch: electromagnetic system.
- Operating modes: light intensity adjustable using magnetic switch.
- Maximum operating depth: 100 mt.
- Light intensity: 500 Lumens.
- Universal torch strap: included.
- Switch lock to prevent accidental ignition.

Linterna para buceo de aluminio con vidrio óptico templado.

- Dimensiones: diámetro 47 mm - longitud 166 mm.
- Peso: 300 gr.
- 1 LED CREE XPG2.
- Batería: ion de litio 18650 en el interior de la linterna, recargable mediante cable micro USB.
- Horas de funcionamiento: 2 horas de luz máxima - 5 horas con energía reducida.
- Ancho del haz lumínico: zoom ajustable, de 12° a 75°.
- Botón de encendido: sistema electromagnético.
- Modos de funcionamiento: intensidad de la luz ajustable usando el interruptor magnético.
- Profundidad máxima de funcionamiento: 100 m.
- Intensidad de la luz: 500 lúmenes.
- Correa universal para linterna: incluida.
- Traba del botón para evitar encendido accidental.



OPTIONAL  
COD. 0530104



COD. 50-5/AN





## R3

Aluminum dive torch with tempered optical glass.

- Dimensions: diameter 42 mm - length 140 mm.
- Weight: 255 g.
- 1 CREE XPG2 LED.
- Battery: Li-Ion 18650 rechargeable via external charger with USB connection.
- Burn-time: 2 hours at max power - 8 hours at reduced power.
- On switch: electromagnetic system.
- Operating modes: max power, reduced power, flashing.
- Maximum operating depth: 100 mt.
- Light intensity: 400 Lumens.
- Universal torch strap: included.
- Battery charger: included.
- Switch lock to prevent accidental ignition.

Linterna para buceo de aluminio con vidrio óptico templado.

- Dimensiones: diámetro 42 mm - longitud 140 mm.
- Peso: 255 gr.
- 1 LED CREE XPG2.
- Batería: ion de litio 18650 recargable mediante cargador externo con conexión USB.
- Horas de funcionamiento: 2 horas de luz máxima - 8 horas con energía reducida.
- Botón de encendido: sistema electromagnético.
- Modos de funcionamiento: energía máxima, energía reducida, modo intermitente.
- Profundidad máxima de funcionamiento: 100 m.
- Intensidad de la luz: 400 lúmenes.
- Correa universal para linterna: incluida.
- Traba del botón para evitar encendido accidental.



OPTIONAL  
COD. 0530104

COD. 50-4/AN



400 LUMEN



SWITCH LOCK

## T5

Aluminum dive torch with tempered optical glass.

- Dimensions: diameter 31.9 mm - length 144 mm.
- Weight: 125 g.
- 1 CREE XPG2 LED.
- Battery: 3 x Alkaline AAA.
- Burn-time: 2.2 hours.
- Width of light beam: 9°.
- On switch: press.
- Maximum operating depth: 100 mt.
- Light intensity: 300 Lumens.
- Universal torch strap: included.
- Switch lock to prevent accidental ignition.

Linterna para buceo de aluminio con vidrio óptico templado.

- Dimensiones: diámetro 31,9 mm - longitud 144 mm.
- Peso: 125 gr.
- 1 LED CREE XPG2.
- Batería: 3 baterías alcalinas AAA.
- Horas de funcionamiento: 2,2 horas.
- Amplitud del haz de luz: 9°.
- Botón de encendido: presionar.
- Profundidad máxima de funcionamiento: 100 m.
- Intensidad de la luz: 300 lúmenes.
- Correa universal para linterna: incluida.



OPTIONAL  
COD. 0530104

COD. 50-26/AN



300 LUMEN

OPTIONAL RECHARGEABLE  
BATTERY T5 - R5 - R3 - R3FX  
BATERÍA RECARGABLE OPCIONAL  
T5 - R5 - R3 - R3FX  
COD. 0530097

OPTIONAL BATTERY CHARGER  
CARGADOR DE BATERÍA OPCIONAL  
COD. 0530098

USB CABLE  
CABLE USB  
COD. 0530099



## Q5

Technopolymer dive torch.

- Type of batteries: Eight 1.5 V AA/R6 alkaline batteries (not included).
- Burn time: 3 hrs at max power.
- Maximum usage depth: 60 m.
- Dimensions: diameter 60 mm - length 180 mm.
- Weight: 457 g (with batteries).
- On switch: electromagnetic system.
- Seal: Double radial seal O-ring + L-Ring.
- Glass: clear polycarbonate.
- Lumens: 700 Lumens.
- 3 Cree XPG R5 LEDs.
- Universal torch strap: included.

- Tipo de pila: ocho baterías alcalinas 1,5 V AA/R6 (no incluidas).
- Autonomía: 3 horas en el modo energía máxima.
- Profundidad máxima de funcionamiento: 60 m.
- Dimensiones: diámetro 60 mm - longitud 180 mm.
- Peso: 457 gr. (Con baterías).
- Botón de encendido: sistema electromagnético.
- Sellado: junta tórica con sellado de doble radial + L-Ring.
- Vidrio: policarbonato transparente.
- Lúmenes: 700 lúmenes.
- Correa universal para linterna: incluida.



OPTIONAL  
COD. 0530104



COD. 50-20/N



## TORCH HOLDER



NEW

COD. 0530104

## USB POWER SUPPLY FOR TORCHES ALIMENTACIÓN USB PARA LINTERNAS



USB battery charger for SEAC® torches.  
Input: 100-240V ~ / 50/60Hz 0.35A max / Output: 5V - 2A

Cargador USB para linternas SEAC®.  
Entrada: 100-240 V ~ / 50/60 Hz 0,35 A máx / Salida: 5 V - 2 A

COD. 0530102

## UNIVERSAL CLIP CLIP UNIVERSAL



COD. 2051N

## TECHNICAL CHARACTERISTICS | CARACTERÍSTICAS TÉCNICAS

TORCE   TORCHES	R40	R30	R15	R5	R3	T5	Q5
MAGNETIC SWITCH BOTÓN DE ENCENDIDO MAGNÉTICO	✓	✓	✓	✓	✓	-	✓
MECHANICAL SWITCH BOTÓN DE ENCENDIDO MECÁNICO	-	-	-	-	-	✓	-
LIGHT FROM 3 LED LUZ PROCEDENTE DE 3 LED	✓	✓	-	-	-	-	✓
LIGHT FROM 1 LED LUZ PROCEDENTE DE 1 LED	-	-	✓	✓	✓	✓	-
THREE MODES TRES MODOS	✓	✓	-	-	✓	-	-
PROGRESSIVE INTENSITY ADJUSTMENT AJUSTE DE INTENSIDAD PROGRESIVA	-	-	✓	✓	-	-	-
DOUBLE RADIAL SEAL O-RING JUNTA TÓRICA CON SELLADO DE DOBLE RADIAL	✓	✓	✓	✓	✓	✓	✓
SEALS SELLADO	O-RING	O-RING	O-RING	O-RING	O-RING	X2	X2
WATT (W)	20	15	9	5	5	5	15
WIDTH OF THE LIGHT BEAM AMPLITUD DEL HAZ DE LUZ	MAX 75° MIN 12°	MAX 75° MIN 12°	MAX 75° MIN 12°	MAX 75° MIN 12°	9°	9°	10°
BURN-TIME AUTONOMÍA (h)	MAX 2 MIN 5	MAX 2 MIN 5	MAX 1.4 MIN 24	MAX 2 MIN 24	MAX 2.15 MIN 8	2.2	MAX 8 MIN 0.30
LUMEN (lm)	MAX 2300 MIN 730	MAX 1500 MIN 450	MAX 900 MIN 50	MAX 500 MIN 50	MAX 400 MIN 120	300	MAX 700 MIN 200
KELVIN (°K)	5700~7300	5700~7300	5700~7300	5700~7300	5700~7300	5700~7300	5700~7300



## Diving suits | Trajes de buceo

From preliminary drawings to the final detailed design, our wetsuit production department monitors every step in the creation of one of the top products in the company catalog.

Our focus on detail, research into materials, close attention, and in-depth quality control make SEAC® wetsuits true icons on the dive market for dry suit, semi-dry suit, and wetsuit models.

Desde los primeros esbozos hasta el momento del diseño con todos sus detalles, nuestro departamento de producción de trajes húmedos supervisa cada uno de los pasos de la creación de uno de los productos estrella de nuestro catálogo. Nuestra atención al detalle, estudio de los materiales y un minucioso control de calidad hacen que los trajes húmedos SEAC® se erijan en verdaderos iconos dentro del mercado del buceo de trajes secos, semisecos y trajes húmedos.



# DRY PLUS 4.0

ITALIAN DESIGN



4 mm



4.0-mm high-density neoprene dry suit double-lined in nylon and waterproof neoprene taping.

- Boot: waterproof in neoprene, and sole with extra-tough PU Print protection on the sole.
- Inlet and exhaust valves: Si-Tech.
- Rear zip: in BDM metal with protective flap.
- Neck: Glide Skin neoprene outside and Superstretch Nylon with external protective flap.
- Closure system at the wrists: Neoprene in Nylon Superstretch and Glide Skin interior.
- Side pocket: in neoprene with YKK zipper.
- Knee pads: in Tatex.
- Hood: separate in superstretch neoprene with fastening buckle in the pocket area.
- Other features: fabric bag, hose and suspenders included.

- Traje seco hecho de neopreno de alta densidad, de 4 mm, con doble capa de nailon y cintas de neopreno impermeable.
- Bota: impermeable de neopreno, con suela extra rígida y protección de impresión PU.
- Válvulas de entrada y vaciado: Si-Tech.
- Cremallera trasera: hecha de metal BDM con solapa de protección.
- Cuello: Neopreno Glide Skin en la parte exterior y nailon superelástico con solapa externa de protección.
- Sistema de cierre en las muñecas: Neopreno en nailon superelástico e interior en Glide Skin.
- Bolsillo lateral: en neopreno con cremallera YKK.
- Rodilleras: en Tatex.
- Capucha: separada, en neopreno superelástico con hebilla de ajuste en el área de los bolsillos.
- Otras Prestaciones: bolsa de tela, capucha y tirantes incluidos.



SIZE   TALLA	XS	S	M	L	L2P	XL
MAN   HOMBRE	-	6-3/S	6-3/M	6-3/L	6-3/L2P	6-3/XL
LADY   MUJER	6-4/XS	6-4/S	6-4/M	6-4/L	-	6-4/XL
BOOTS   ESCARPINES	36/37	37/38	39/40	40/41	40/41	41/42

SIZE   TALLA	XL2P	XXL	XXL2P	XXXL	XXXL2P	XXXXL
MAN   HOMBRE	6-3/XL2P	6-3/XXL	6-3/XXL2P	6-3/XXXL	6-3/XXXL2P	6-3/XXXXL
LADY   MUJER	-	6-4/XXL	-	-	-	-
BOOTS   ESCARPINES	41/42	43/44	43/44	44/45	44/45	45/46



## UNIFLEECE



Double-layer water-repellent undersuit ideal for wearing under a drysuit. Lightweight (~ 600 g.) and breathable, it's ideal for staying warm during dives in especially cold places. The front zips from both ends to make it quick and easy to put on. The easy-access zip pockets are perfect for carrying small tools.

Traje interior doble capa que repele el agua, ideal para colocar debajo de un traje seco. Liviano (~ 600 gr.) y respirable, es ideal para mantenerse caliente durante las inmersiones realizadas especialmente en lugares fríos. Las cremalleras delanteras de ambos extremos permiten colocar el traje fácil y rápidamente. Los bolsillos con cremallera son de fácil acceso e ideales para transportar herramientas pequeñas.

SIZE   TALLA	XS	S	M	L	XL	XXL	XXXL
COD.	11-1/XS	11-1/S	11-1/M	11-1/L	11-1/XL	11-1/XXL	11-1/XXXL



# WARMDRY

ITALIAN DESIGN



4 mm

- Dry suit.
- External coating: Heavy Duty Poly PK + Powertex.
- Lining: Nylon.
- Zip: DRY BDM in metal with protective flap.
- Stitching: External blind stitching.
- Internal neoprene Tape.
- Neck: Glide Skin.
- Closure system on the wrists: Aquastop Smooth Skin.
- Other features: textile bag, hood, hose and suspenders included.
- Semi-rigid boots can be turned inside out. Convenient large pocket in 1000D Cordura, expandable and with Velcro flap.
- Total Protection on the shoulders, elbows, knees, and lower back, in ultras resistant material.

- Traje seco.
- Revestimiento externo: PK de poliéster resistente + Powertex.
- Forro: nailon.
- Cremallera: DRY BDM en metal con solapa de protección.
- Costuras: costuras externas ciegas.
- Cinta interna de neopreno.
- Cuello: Glide Skin.
- Sistema de cierre en las muñecas: Aquastop Smooth Skin.
- Otras Prestaciones: bolsa de tela, capucha, latiguillo y tirantes incluidos.



SIZE   TALLA	S	M	L	L2P	XL	XL2P	XXL	XXL2P	XXXL	XXXL2P	XXXXL
COD.	6-1/S	6-1/M	6-1/L	6-1/L2P	6-1/XL	6-1/XL2P	6-1/XXL	6-1/XXL2P	6-1/XXXL	6-1/XXXL2P	6-1/XXXXL
BOOTS   ESCARPINES	37/38	39/40	40/41	40/41	41/42	41/42	43/44	43/44	44/45	44/45	45/46

DRY SUIT HOSE   LATIGUILLO PARA TRAJE SECO	
COD.	S850100
VERSION	75 cm

## NEOPRENE GLUE | MASILLA



Liquid neoprene adhesive for small repairs, 30 g.

Adhesivo de neopreno líquido para reparaciones pequeñas, 30 g.

COD. 699

## HANGER | PERCHA



Universal hanger with special spaces for each component of your scuba equipment.

Percha universal con espacios especiales para cada uno de los componentes del equipo de buceo.

COD. 2200



# MASTERDRY

ITALIAN DESIGN

Semi-dry suit in superelastic neoprene with rear zip. Model with separate hood, included, with Air Draining system, double cone cuffs and ankles in ultra-elastic smooth skin. Three-dimensional pocket with zip closure.

- External coating: 300% Extraflex superelastic nylon.
- Lining: Thermal Fiber Plush.
- Zip: Titex Master Seal.
- Cuffs and ankles: double cone ultra-elastic Smooth Skin.
- Hood: separate, included, with "Air Draining" system.
- Other features: Rear horizontal Master Seal zip to ensure the utmost flexibility and comfort when moving. Thermal Fiber Plush: highly elastic, dries quickly, warm and comfortable against the skin. PAD Protection in the back area.

- Traje semiseco en neopreno extraelástico con cremallera en la espalda. Modelo con capucha independiente incluida y sistema de secado por aire; puños y tobillos confeccionados en Smooth Skin ultraelástica en forma de doble cono. Bolsillo en tres dimensiones con cierre de cremallera.
- Revestimiento externo: nailon 300 % Extraflex extraelástico
- Forro: Thermal Fiber Plush
- Cremallera: Titex Master Seal
- Puños y tobillos: Smooth Skin ultraelástica en forma de doble cono
- Capucha: por separado, e incluida con sistema de "secado por aire".
- Otras características: cremallera Master Seal horizontal en la espalda para garantizar una flexibilidad y comodidad máximas de nuestros movimientos. Tejido Thermal Fiber Plush: altamente elástico, de secado rápido, y cálido y cómodo al contacto con la piel. Protección PAD en la espalda.

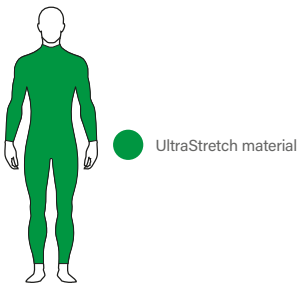

7 mm



SIZE   TALLA	XS	S	M	MT	L	LT	XL	XLT	XXL	XXXL	XXXXL
MAN   HOMBRE	-	1-6/S	1-6/M	1-6/MT	1-6/L	1-6/LT	1-6/XL	1-6/XLT	1-6/XXL	1-6/XXXL	1-6/XXXXL
LADY   MUJER	1-7/XS	1-7/S	1-7/M	-	1-7/L	-	1-7/XL	-	1-7/XXL	-	-

# KOMODA FLEX 7.0

ITALIAN DESIGN

7 mm one-piece suit with rear YKK zip, stainless steel sliding tab, made in superelastic double-lined neoprene. The special rear Water Barrier System closure minimizes water seepage. Model with Aquastop at the cuffs and ankles thanks to the double cone system and zip closure. Water Barrier System to waterproof the zipper. Knee pads in scratch-resistant polyurethane.

Monotraje de 7 mm con cremallera YKK en la espalda y pestaña deslizante de acero inoxidable, que se ha confeccionado en una doble capa de neopreno ultraelástico. El cierre especial Water Barrier System en la espalda minimiza cualquier filtrado de agua. Modelo con Aquastop en los puños y tobillos gracias al sistema de doble cono y cierre de cremallera. Rodilleros en scratch-resistente poliuretano.



Possible matching with: **VEST FLEX 5.0**  
Puede combinarse con: **VEST FLEX 5.0**

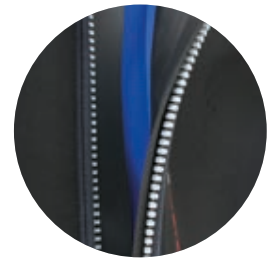
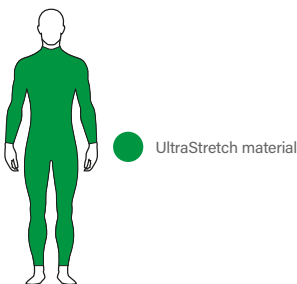

SIZE   TALLA	XS	S	M	MP	L	LP	LT	XL
MAN   HOMBRE	-	1-60/S	1-60/M	-	1-60/L	1-60/LP	1-60/LT	1-60/XL
LADY   MUJER	1-63/XS	1-63/S	1-63/M	1-63/MP	1-63/L	1-63/LP	-	1-63/XL
SIZE   TALLA	XLP	XLT	XXL	XXLP	XXLT	XXXL	XXXLP	XXXXL
MAN   HOMBRE	1-60/XLP	1-60/XLT	1-60/XXL	1-60/XXLP	1-60/XXLT	1-60/XXXL	1-60/XXXLP	1-60/XXXXL
LADY   MUJER	1-63/XLP	-	1-63/XXL	-	-	-	-	-

# KOMODA FLEX 5.0

ITALIAN DESIGN



5 mm one-piece suit with rear YKK zip, stainless steel sliding tab, made in superelastic double-lined neoprene. The special rear Water Barrier System closure minimizes water seepage. Model with Aquastop at the cuffs and ankles thanks to the double cone system and zip closure. Rubber with honeycomb structure: advanced elasticity, excellent heat insulation, and unparalleled light weight.

Monotraje de 5 mm con cremallera YKK en la espalda y pestaña deslizante de acero inoxidable, que se ha confeccionado en una doble capa de neopreno ultraelástico. El cierre especial Water Barrier System en la espalda minimiza cualquier filtrado de agua. Modelo con Aquastop en los puños y tobillos gracias al sistema de doble cono y cierre de cremallera. Goma con estructura de panel: elasticidad avanzada, aislamiento térmico perfecto y un peso ligero incomparable.

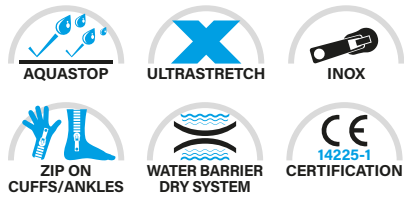

Possible matching with: **VEST FLEX 5.0**  
Puede combinarse con: **VEST FLEX 5.0**



UltraStretch material



SIZE   TALLA	XS	S	M	MP	L	LP	LT	XL
MAN   HOMBRE	-	1-61/S	1-61/M	-	1-61/L	1-61/LP	1-61/LT	1-61/XL
LADY   MUJER	1-64/XS	1-64/S	1-64/M	1-64/MP	1-64/L	1-64/LP	-	1-64/XL

  

SIZE   TALLA	XLP	XLT	XXL	XXLP	XXLT	XXXL	XXXLP	XXXXL
MAN   HOMBRE	1-61/XLP	1-61/XLT	1-61/XXL	1-61/XXLP	1-61/XXLT	1-61/XXXL	1-61/XXXLP	1-61/XXXXL
LADY   MUJER	1-64/XLP	-	1-64/XXL	-	-	-	-	-



# VEST FLEX 5.0

ITALIAN DESIGN

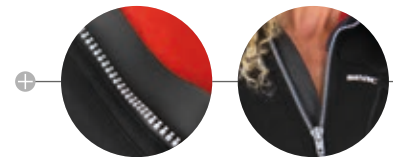

SIZE   TALLA	XS	S	M	MP	L	LP	LT	XL
MAN   HOMBRE	-	1-36/S	1-36/M	-	1-36/L	1-36/LP	1-36/LT	1-36/XL
LADY   MUJER	1-110/XS	1-110/S	1-110/M	1-110/MP	1-110/L	1-110/LP	-	1-110/XL

SIZE   TALLA	XLP	XLT	XXL	XXLP	XXLT	XXXL	XXXLP	XXXXL
MAN   HOMBRE	1-36/XLP	1-36/XLT	1-36/XXL	1-36/XXLP	1-36/XXLT	1-36/XXXL	1-36/XXXLP	1-36/XXXXL
LADY   MUJER	1-110/XLP	-	1-110/XXL	-	-	-	-	-



# ALFA 7.0 / 5.0

ITALIAN DESIGN



7 mm

5 mm



scuba | 2020

One-piece wetsuit in soft 7-mm or 5-mm neoprene. Increases freedom of movement and decreases fatigue thanks to the super-elastic neoprene inserts on the chest, arms, calves, and underarms. AquaStop System at the wrists, ankles, and neck in Smooth Skin neoprene. Knee pads reinforced in Pu-Print, which doesn't compromise the elasticity. Rear vertical zip closure.

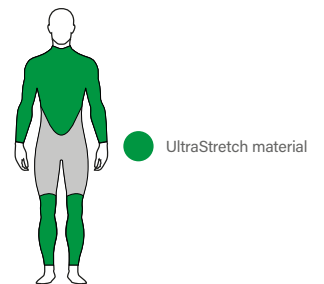

Traje húmedo de una sola pieza, hecho en neopreno suave de 5 o 7 mm. Incrementa la libertad de movimiento y disminuye la fatiga, gracias a las inserciones de neopreno extra elástico en el pecho, los brazos, las pantorrillas y las axilas. Sistema AquaStop en puños y tobillos. Cuello en neopreno Smooth Skin. Rodilleras reforzadas en PU, que no compromete la elasticidad. Cierre con cremallera vertical trasera.



Association possible avec: **VEST FLEX 5.0**  
Puede combinarse con: **VEST FLEX 5.0**

SIZE   TALLA	XS	S	M	L	XL	XXL	XXXL
MAN   HOMBRE 7 MM	-	1-54/S	1-54/M	1-54/L	1-54/XL	1-54/XXL	1-54/XXXL
LADY   MUJER 7 MM	1-57/XS	1-57/S	1-57/M	1-57/L	1-57/XL	1-57/XXL	-
SIZE   TALLA	XS	S	M	L	XL	XXL	XXXL
MAN   HOMBRE 5 MM	-	1-55/S	1-55/M	1-55/L	1-55/XL	1-55/XXL	1-55/XXXL
LADY   MUJER 5 MM	1-58/XS	1-58/S	1-58/M	1-58/L	1-58/XL	1-58/XXL	-

# RESORT FLEX MAN 7.0 / 5.0 RESORT FLEX LADY 5.0

ITALIAN DESIGN



7 mm

5 mm



One-piece wetsuit with integrated hood, made in a soft double-lined neoprene with superelastic inserts on the arms, chest, and hood. New fit. Powertex protections on the shoulders, knee pads, and lower back.

Front YKK zip with new side closure system on the face and inner flap. Comfortable closure at ankles with YKK zip. New cut with Comfort Fit.

Traje húmedo de una sola pieza con capucha integrada, hecho en neopreno suave doble capa e inserciones extra elásticas en brazos, pecho y capucha. Nuevo ajuste. Protecciones de Powertex en hombros, rodilleras y zona lumbar.

Cremallera YKK delantera con nuevo sistema de cierre lateral en la cara y solapa interior. Comodidad en tobillos con un cierre de cremallera YKK. Nuevo corte con Comfort Fit.

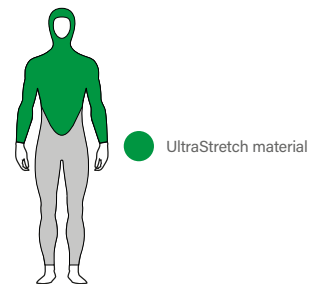

SIZE   TALLA	S	M	L	XL	XXL	XXXL	XXXXL
MAN   HOMBRE 7 MM	1-85/S	1-85/M	1-85/L	1-85/XL	1-85/XXL	1-85/XXXL	1-85/XXXXL
SIZE   TALLA	XS	S	M	L	XL	XXL	XXXL
MAN   HOMBRE 5 MM	-	1-86/S	1-86/M	1-86/L	1-86/XL	1-86/XXL	1-86/XXXL
LADY   MUJER 5 MM	1-109/XS	1-109/S	1-109/M	1-109/L	1-109/XL	1-109/XXL	-



# RIESE 8.5 MM

ITALIAN DESIGN



8.5 mm

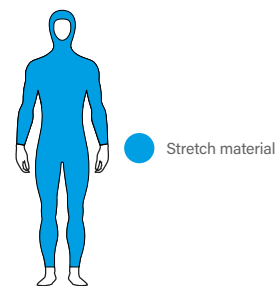

8.5 mm two-piece suit consisting of a hooded jacket and Farmer John. Made in soft double-lined neoprene, this model features an anatomical, preformed cut on the arms and legs. Knee pads reinforced with latest-generation Supratex II.

Traje de dos piezas de 8,5 mm que consiste en una chaqueta con capucha y mono de tirantes. Fabricado en neopreno de doble forro suave, este modelo presenta un corte anatómico y ergonómico en tanto brazos como piernas. Odilleras reforzadas con el tejido de nailon ergonómico de última generación Supratex II.



SIZE   TALLA	S	M	L	XL	XXL	XXXL
COD.	1-48/S	1-48/M	1-48/L	1-48/XL	1-48/XXL	1-48/XXXL

# PRIVILEGE FLEX 5.0

ITALIAN DESIGN



5 mm



5-mm two-piece suit consisting of a hooded jacket and Farmer John. New fit. Front YKK zip with new side closure system on the face and inner flap. Made of soft double-lined neoprene with superelastic inserts on the arms, chest, and hood. Anatomical and preformed cut on the arms and legs. Knee pads reinforced in Pu-Print, which doesn't compromise the elasticity.

Traje de dos piezas de 5 mm que consiste en una chaqueta con capucha y mono de tirantes. Nuevo ajuste. Cremallera YKK delantera con nuevo sistema de cierre lateral en la cara y solapa interior. Hecho en neopreno suave doble capa e inserciones extra elásticas en brazos, pecho y capucha. Corte anatómico y ergonómico en brazos y piernas. Rodilleras reforzadas en PU, que no compromete la elasticidad.

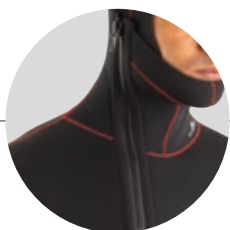

UltraStretch material

SIZE   TALLA	S	M	L	XL	XXL	XXXL
MAN   HOMBRE 5 MM	1-81/S	1-81/M	1-81/L	1-81/XL	1-81/XXL	1-81/XXXL

# FEEL ULTRAFLEX 3.0

ITALIAN DESIGN



3 mm



One-piece suit entirely in 3-mm superstretch neoprene delivers the maximum in elasticity and comfort, perfect for dives in tropical seas or temperate waters, and ideal for any water sport, like snorkeling, freediving, or swimming. Flatlock stitching and Kneepads reinforced with Powertex. Rear vertical closure with YKK zip.

Traje de una sola pieza hecho enteramente de neopreno superelástico de 3 mm, que ofrece máxima elasticidad y comodidad, perfecto para inmersiones en mares tropicales o agua templada, e ideal para practicar cualquier deporte acuático como esnórquel, apnea o natación. Costura plana y rodilleras reforzadas con Powertex. Cierre con cremallera vertical trasera.

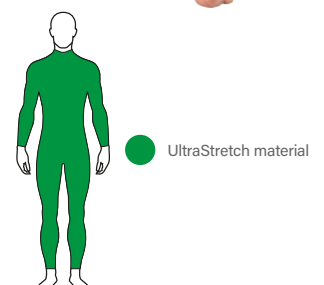

SIZE   TALLA	XS	S	M	L	XL	XXL	XXXL
MAN   HOMBRE	-	1-89/S	1-89/M	1-89/L	1-89/XL	1-89/XXL	1-89/XXXL
LADY   MUJER	1-90XS	1-90/S	1-90/M	1-90/L	1-90/XL	1-90/XXL	-



# SENSE LONG / SENSE SHORT

ITALIAN DESIGN



3 mm

2.5 mm

scuba | 2020



One-piece suit in double-lined 3 mm neoprene or one-piece shorty in double-lined 2.5 mm neoprene with rear zip and stainless steel sliding tab. Superelastic inserts at the collar and arms. Aquastop on the wrists and ankles with Smooth Skin seal. Powertex knee pads. Adjustable Velcro.

Traje en una sola pieza confeccionado en una doble capa de neopreno de 3 mm, con cremallera en la espalda y tirador deslizante en acero inoxidable. Inserciones extraelásticas en cuello y brazos.

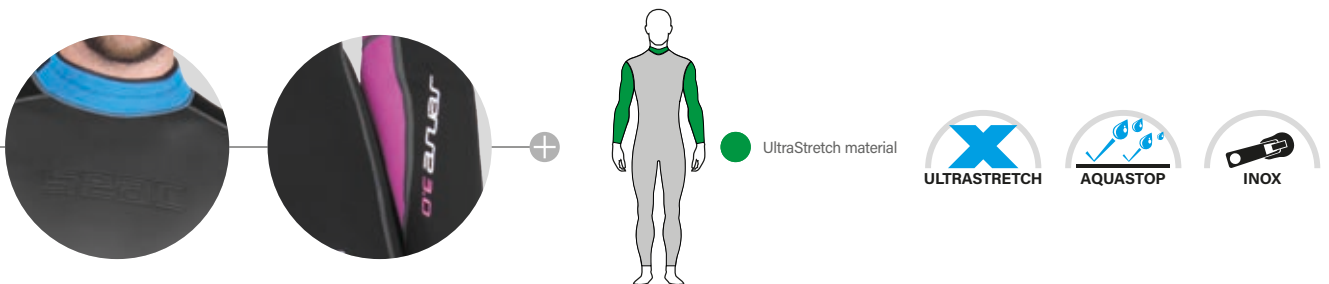

SIZE   TALLA	XS	S	M	L	XL	XXL	XXXL	XXXXL
SENSE LONG MAN   HOMBRE	-	1-26/S	1-26/M	1-26/L	1-26/XL	1-26/XXL	1-26/XXXL	1-26/XXXXL
SENSE LONG LADY   MUJER	1-27/XS	1-27/S	1-27/M	1-27/L	1-27/XL	1-27/XXL	-	-
SIZE   TALLA	XS	S	M	L	XL	XXL	XXXL	XXXXL
SENSE SHORT MAN   HOMBRE	-	1-28/S	1-28/M	1-28/L	1-28/XL	1-28/XXL	1-28/XXXL	1-28/XXXXL
SENSE SHORT LADY   MUJER	1-29/XS	1-29/S	1-29/M	1-29/L	1-29/XL	1-29/XXL	-	-

# RELAX LONG / RELAX SHORT

ITALIAN DESIGN



2.2 mm



Suit and one-piece shorty with rear zip in 2.2-mm double-lined neoprene. The preformed, anatomical cut with flat-lock stitching makes this an ideal suit for water sports like surfing, snorkeling, swimming, and kayaking. Knee pads with polyurethane protection.

Traje entero y traje solo de una sola pieza con cremallera en la espalda y confeccionado en una doble capa de neopreno de 2,2 mm. Corte ergonómico y anatómico cosido mediante el sistema de costura plana hacen que este traje resulte ideal para deportes acuáticos como, por ejemplo, surf, esnórquel, natación o salidas en kayak. Rodilleras con protecciones de poliuretano.

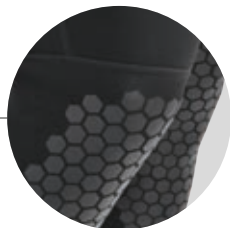

SIZE   TALLA	XS	S	M	L	XL	XXL	XXXL	XXXXL
RELAX LONG MAN   HOMBRE	-	1-41/S	1-41/M	1-41/L	1-41/XL	1-41/XXL	1-41/XXXL	1-41/XXXXL
RELAX LONG LADY   MUJER	1-42/XS	1-42/S	1-42/M	1-42/L	1-42/XL	1-42/XXL	-	-
SIZE   TALLA	XS	S	M	L	XL	XXL	XXXL	XXXXL
RELAX SHORT MAN   HOMBRE	-	1-39/S	1-39/M	1-39/L	1-39/XL	1-39/XXL	1-39/XXXL	1-39/XXXXL
RELAX SHORT LADY   MUJER	1-40/XS	1-40/S	1-40/M	1-40/L	1-40/XL	1-40/XXL	-	-

# CIAO

ITALIAN DESIGN



2.5 mm

Shorty for water sports. Front zip makes it easy to put on. Double-lined 2.5 mm neoprene model with flat-lock stitching. Flap inside the zip to prevent seepage. Scratch-resistant Lycra finish on the collar.

Traje corto para la práctica de deportes acuáticos. La cremallera en la parte delantera hace que sea más fácil de poner. Modelo de neopreno de doble capa y 2,5 mm de grosor confeccionado con el sistema de costura plana. Solapa en el interior de la cremallera para evitar el filtrado de agua. Acabados en el cuello con licra resistente a las rasgaduras.



SIZE   TALLA	XS	S	M	L	XL	XXL	XXXL	XXXXL
MAN   HOMBRE	-	1-18/S	1-18/M	1-18/L	1-18/XL	1-18/XXL	1-18/XXXL	1-18/XXXXL
LADY   MUJER	1-19/XS	1-19/S	1-19/M	1-19/L	1-19/XL	1-19/XXL	-	-

# CIAO KID

Double-lined neoprene shorty for kids with front zip.

Traje corto para niño con doble capa de neopreno y cremallera delantera.



2.5 mm



AGE   EDAD	5	7	9	11	13
BOY   NIÑO	1-20/5A	1-20/7A	1-20/9A	1-20/11A	1-20/13A

# DOLPHIN



1.5 mm

NEW

Neoprene kids' shorty with front zip and standard nylon lining. In Lycra, with UV Protection on the arms and legs.

Traje corto para niño en neopreno con cremallera delantera y forro en nailon estándar. Brazos y piernas en licra con protección UV.



AGE   EDAD	3	5	7
BOY   NIÑO	1-87/3A	1-87/5A	1-87/7A
GIRL   NIÑA	1-88/3A	1-88/5A	1-88/7A

AGE   EDAD	9	11	13
BOY   NIÑO	1-87/9A	1-87/11A	1-87/13A
GIRL   NIÑA	1-88/9A	1-88/11A	1-88/13A



# FIT LONG 2.0 / FIT SHORT 2.0

ITALIAN DESIGN



2 mm



2.0-mm UltraStretch neoprene vest, collar with smooth-skin aquastop system. High-visibility fluorescent white-orange color, ideal for swimming in open water, and underarm cut with no stitches to ensure maximum comfort. Perfect for use in temperate water or for any water sport, like snorkeling, freediving, swimming, or as an undersuit. Flatlock Stitching.

Chaleco de neopreno UltraStretch de 2 mm, collar con sistema Aquastop Smooth Skin. Color blanco y anaranjado fluorescente que brinda alta visibilidad, ideal para nadar en aguas abiertas. Tiene un corte en las axilas sin costuras, para garantizar la máxima comodidad. Perfecto para usar en agua templada o para practicar cualquier deporte acuático como esnórquel, apnea, natación o como traje interior. Costura plana.

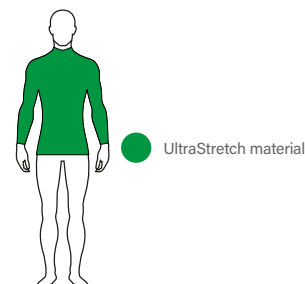

SIZE   TALLA	S	M	L	XL	XXL	XXXL
FIT LONG MAN   HOMBRE	11-6/S	11-6/M	11-6/L	11-6/XL	11-6/XXL	11-6/XXXL
FIT SHORT MAN   HOMBRE	11-8/S	11-8/M	11-8/L	11-8/XL	11-8/XXL	11-8/XXXL

## SHORT VEST

2.5 mm undersuit vest.

Chaleco interior de 2,5 mm.



2.5 mm



SIZE   TALLA	XS	S	M	L	XL	XXL	XXXL
MAN   HOMBRE	-	11-4/S	11-4/M	11-4/L	11-4/XL	11-4/XXL	11-4/XXXL
LADY   MUJER	11-5/XS	11-5/S	11-5/M	11-5/L	11-5/XL	-	-

**WARMGUARD COMFORT LONG | SHORT**0.5  
mm

Long-sleeve suit in 0.5 mm compressed neoprene.

Traje de manga larga en neopreno comprimido de 0.5 mm.

Short-sleeve suit in 0.5 mm compressed neoprene.

Traje de manga corta en en neopreno comprimido de 0.5 mm.

SIZE   TALLA	XS	S	M	L	XL	XXL
LONG MAN   HOMBRE	155-7/XS	155-7/S	155-7/M	155-7/L	155-7/XL	155-7/XXL
LONG LADY   MUJER	9320/01	9320/02	9320/03	9320/04	9320/05	-
SHORT MAN   HOMBRE	155-8/XS	155-8/S	155-8/M	155-8/L	155-8/XL	155-8/XXL
SHORT LADY   MUJER	9321/01	9321/02	9321/03	9321/04	9321/05	-

**TEKNO**

5 mm super-elastic Ultraflex/Thermal Fiber neoprene.

Smooth exterior on the neck to ensure it adheres better to the wetsuit. The "Air Release" valve vents air.

Neopreno extra elástico 5 mm Ultraflex/Thermal Fiber. Exterior suave en la parte del cuello para garantizar la mejor adherencia al traje seco. La válvula «Air Release» permite ventilar el aire.

SIZE   TALLA	XS/S	M	L	XL	XXL/XXXL
COD.	26-1/XS-S	26-1/M	26-1/L	26-1/XL	26-1/XXL-XXXL

5  
mm**STANDARD**

Double-lined neoprene available in 3 mm or 5 mm with air venting holes.

Confeccionado en una doble capa de neopreno en 3 o 5 mm con unos orificios de ventilación.

SIZE   TALLA	XS/S	M	L	XL	XXL
STANDARD 5 MM	71601/XS	71603/M	71604/L	71605/XL	71606/XXL
STANDARD 3 MM	73501/XS	73503/M	73504/L	73505/XL	73506/XXL

3  
mm5  
mm

### DRY SEAL 300/500

3/5 mm glove in Superstretch neoprene to ensure maximum comfort. 100% waterproof thanks to the Liquid Seal on the stitching and the innovative internal Glide Skin ring with the Aquastop Ring Seal system. Maximum heat retention is further enhanced by our choice of Therma Fiber plush for the lining. Palms reinforced with Rubber Coated cut-resistant material.

Guante de 3 o 5 mm que se ha confeccionado en neopreno Superstretch para garantizar una comodidad máxima. Impermeabilidad 100 % gracias al sistema Liquid Seal en la costura y el innovador anillo interior en Glide Skin que integra también el sistema Aquastop Ring Seal. Su capacidad de retención máxima del calor se ha mejorado incluso más gracias a nuestra elección de Therma Fiber Plush para el forro. Palmas de las manos reforzadas mediante un material de recubrimiento en goma resistente a los cortes.



SIZE   TALLA	S	M	L	XL	XXL
DRY SEAL 300	03001/02	03001/03	03001/04	03001/05	03001/06
DRY SEAL 500	03002/02	03002/03	03002/04	03002/05	03002/06

### ULTRAFLEX



Ultraflex neoprene glove with Rubber Coated palm.

Guante de neopreno Ultraflex y palma de la mano con recubrimiento de goma.



SIZE   TALLA	XS	S	M	L	XL	XXL
ULTRAFLEX 2 MM	16-11/XS	16-11/S	16-11/M	16-11/L	16-11/XL	16-11/XXL
ULTRAFLEX 3.5 MM	16-10/XS	16-10/S	16-10/M	16-10/L	16-10/XL	16-10/XXL
ULTRAFLEX 5 MM	16-9/XS	16-9/S	16-9/M	16-9/L	16-9/XL	16-9/XXL

### AMARA COMFORT

1.5 mm glove in standard nylon, amara on the palm, and Velcro closure with elastic.

Guante de 1,5 mm confeccionado en nailon estándar, amara en la palma de la mano y cierre de Velcro con tira elástica.



SIZE   TALLA	XS	S	M	L	XL	XXL
COD.	16-8/XS	16-8/S	16-8/M	16-8/L	16-8/XL	16-8/XXL

### COMFORT 3.0

3.0 mm standard nylon glove, palm in non-slip PU.

Guante de nailon estándar de 3 mm y palma en PU antideslizante.



SIZE   TALLA	XXS	XS	S	M	L	XL	XXL
COMFORT 3.0	16-12/XXS	16-12/XS	16-12/S	16-12/M	16-12/L	16-12/XL	16-12/XXL



**ROCK BOOT HD**

Boot with rigid sole designed for use with dry suits and soft-bootie dry suits. Quick closure. Excellent grip in all conditions of use. Comfortable and lightweight.

Escarpín con suela rígida diseñado para usar con trajes secos o trajes secos con escafpines blandos. Cierre rápido. Excelente agarre en cualquier condición de uso. Cómodo y liviano.



SIZE   TALLA	S	M	L	XL	XXL	XXXL
COD.	72902/S	72903/M	72904/L	72905/XL	72906/XXL	72907/XXXL

**PRO HD**

**6**  
mm

6 mm shoe with high grip sole and zip making it easier to put on.

Este zapato de 6 mm presenta una suela de gran capacidad de agarre y su cremallera hace que sea más fácil de poner.



SIZE   TALLA	XXS	XS	S	M	L	XL	XXL
COD.	68000/XXS	68001/XS	68002/S	68003/M	68004/L	68005/XL	68006/XXL

**BASIC HD**

**5**  
mm

5 mm boot with semi-rigid sole, PU protection on the instep, fin strap notch on the heel, and lining in standard nylon.

Escarpín de 5 mm con suela semirrígida, protección de PU en el empeine, muesca para la correa de la aleta en el talón y forro de nailon estándar.



SIZE   TALLA	XXS	XS	S	M	L	XL	XXL
COD.	67900/XXS	67901/XS	67902/S	67903/M	67904/L	67905/XL	67906/XXL

**REGULAR**

**5**  
mm

5 mm boot with semi-rigid sole and PU protection on the instep.

Escarpín de 5 mm con suela semirrígida y protección de PU en el empeine.



SIZE   TALLA	XXS	XS	S	M	L	XL	XXL
COD.	21-4/XXS	21-4/XS	21-4/S	21-4/M	21-4/L	21-4/XL	21-4/XXL

## ANATOMIC

3.5/5/7 mm neoprene socks with top in "Smooth Skin" and Supratex sole.

Escarpín anatómico de 3,5/5/7 mm con la parte superior confeccionada en Smooth Skin y suela de Supratex.



3.5  
mm  
5  
mm  
7  
mm

SIZE   TALLA	S	M	L	XL	XXL
ANATOMIC 3.5 MM	0404/02	0404/03	0404/04	0404/05	0404/06
ANATOMIC 5 MM	0405/02	0405/03	0405/04	0405/05	0405/06
ANATOMIC 7 MM	0406/02	0406/03	0406/04	0406/05	0406/06

## STANDARD HD

2.5 mm diving socks in standard nylon.

Escarpín anatómico de 2,5 mm confeccionado en nailon estándar.



2.5  
mm

SIZE   TALLA	XS	S	M	L	XL	XXL
COD.	0403/01	0403/02	0403/03	0403/04	0403/05	0403/06

## TECHNICAL CHARACTERISTICS | CARACTERÍSTICAS TÉCNICAS\*

HOODS SIZE TALLA DE CAPUCHAS	XS	S	M	L	XL	XXL	XXXL
HEAD CIRCUMFERENCE - cm CIRCUNFERENCIA DE LA CABEZA - cm	53 - 54	55 - 56	57 - 58	59 - 60	61 - 62	63 - 64	65 - 66

GLOVES SIZE TALLA DE GUANTES	XS	S	M	L	XL	XL
SIZE   TALLA	6	7	8	9	10	11
PALM CIRCUMFERENCE - cm CIRCUNFERENCIA DE PALMA - cm	19 - 20.5	20.5 - 22	22 - 23.5	23.5 - 25	25 - 26.5	26.5 - 28

BOOTS SIZE TALLA DE ESCARPINES	XXS	XS	S	M	L	XL	XXL
EU SIZE   TALLA EU	36 - 37	37 - 38	38 - 39	40 - 41	42 - 43	43 - 44	45 - 46
FOOT LENGTH - cm LONGITUD DEL PIE - cm	23	24	25	26	27	28	29

\* The measures are indicative and may vary depending on the model.  
\* Las medidas son indicativas y pueden variar según el modelo.

\* The measures are indicative and may vary depending on the model.  
 \* Las medidas son indicativas y pueden variar según el modelo.

**ADULT DRYSUITS | TRAJES SECOS PARA ADULTO**

SIZE TALLA	WEIGHT PESO		HEIGHT ALTURA		CHEST PECHO		WAIST CINTURA		HIPS CADERAS		BOOTS ESCARPIN	
	kg	lb	cm	in	cm	in	cm	in	cm	in		
MAN HOMBRE	S	60-69	132-152	167-172	65.7-67.7	94-98	25.1-38.5	76-80	29.9-31.4	88-92	34.6-36.2	26
	M	68-77	149-169	172-176	67.7-69.2	98-102	38.5-40.1	80-84	31.4-33.0	92-96	36.2-37.7	27
	L	76-85	167-187	176-180	69.2-70.8	102-106	40.1-41.7	84-88	33.0-34.6	96-100	37.7-39.3	28
	L2P	84-94	185-207	176-180	69.2-70.8	112-118	44.0-46.4	94-100	37.0-39.3	106-112	41.7-44.0	28
	XL	84-94	185-207	180-184	70.8-72.4	106-110	41.7-43.3	88-92	34.6-36.2	100-104	39.3-40.9	29
	XL2P	93-103	205-227	180-184	70.8-72.4	118-124	45.6-48.8	100-106	39.3-41.7	112-118	44.0-46.4	29
	XXL	93-103	205-227	184-188	72.4-74.0	112-118	44.0-46.4	94-100	37.0-39.3	106-112	41.7-44.0	30
	XXL2P	102-114	224-251	184-188	72.4-74.0	124-130	48.0-49.6	106-110	40.9-42.5	118-122	45.6-48.0	30
	XXXL	102-114	224-251	188-192	74.0-75.5	118-124	45.6-48.8	100-106	39.3-41.7	112-118	44.0-46.4	31
	XXXL2P	110-125	242-275	188-192	74.0-75.5	130-134	51.1-52.7	112-116	44.0-45.6	124-130	48.8-51.5	31
LADY MUJER	XS	156-160	61.4-62.9	40-49	88-108	84-88	33.0-34.6	68-72	26.7-28.3	84-88	33.0-34.6	22
	S	160-164	62.9-64.5	47-56	103-123	88-92	34.6-36.2	72-76	28.3-29.9	88-92	34.6-36.2	23
	M	164-168	64.5-66.1	54-63	119-138	92-96	36.2-37.7	76-80	29.9-31.4	92-96	36.2-37.7	24
	L	168-172	66.1-67.7	61-70	134-154	96-100	37.7-39.3	80-84	31.4-33.0	96-100	37.7-39.3	25
	XL	172-178	67.7-70.0	68-77	149-169	100-104	39.3-40.9	84-88	33.0-34.6	100-104	39.3-40.9	26
	XXL	176-180	69.2-70.8	77-89	169-196	104-108	40.9-42.5	88-92	34.6-36.2	104-108	40.9-42.5	27

**ADULT WETSUITS | TRAJES PARA ADULTO**

SIZE TALLA	WEIGHT PESO		HEIGHT ALTURA		CHEST PECHO		WAIST CINTURA		HIPS CADERAS		
	kg	lb	cm	in	cm	in	cm	in	cm	in	
MAN HOMBRE	S	60-69	132-152	167-172	65.7-67.7	94-98	25.1-38.5	76-80	29.9-31.4	88-92	34.6-36.2
	M	68-77	149-169	172-176	67.7-69.2	98-102	38.5-40.1	80-84	31.4-33.0	92-96	36.2-37.7
	L	76-85	167-187	176-180	69.2-70.8	102-106	40.1-41.7	84-88	33.0-34.6	96-100	37.7-39.3
	LT	76-85	167-187	180-184	70.8-72.4	102-106	40.1-41.7	84-88	33.0-34.6	96-100	37.7-39.3
	LP	84-94	185-207	176-180	69.2-70.8	106-110	41.7-43.3	88-92	34.6-36.2	100-104	39.3-40.9
	XL	84-94	185-207	180-184	70.8-72.4	106-110	41.7-43.3	88-92	34.6-36.2	100-104	39.3-40.9
	XLT	84-94	185-207	184-188	72.4-74.0	106-110	41.7-43.3	88-92	34.6-36.2	100-104	39.3-40.9
	XLP	93-103	205-227	180-184	70.8-72.4	112-118	44.0-46.4	94-100	37.0-39.3	106-112	41.7-44.0
	XXL	93-103	205-227	184-188	72.4-74.0	112-118	44.0-46.4	94-100	37.0-39.3	106-112	41.7-44.0
	XXLT	93-103	205-227	188-192	74.0-75.5	112-118	44.0-46.4	94-100	37.0-39.3	106-112	41.7-44.0
	XXLP	102-114	224-251	184-188	72.4-74.0	118-124	45.6-48.8	100-106	39.3-41.7	112-118	44.0-46.4
	XXXL	102-114	224-251	188-192	74.0-75.5	118-124	45.6-48.8	100-106	39.3-41.7	112-118	44.0-46.4
	XXXLT	102-114	224-251	192-196	75.5-77.1	118-124	45.6-48.8	100-106	39.3-41.7	112-118	44.0-46.4
	XXXLP	110-125	242-275	188-192	74.0-75.5	122-126	48.0-49.6	104-108	40.9-42.5	116-120	45.6-47.2
	XXXXL	110-125	242-275	192-196	75.5-77.1	122-126	48.0-49.6	104-108	40.9-42.5	116-120	45.6-47.2
LADY MUJER	XS	40-49	88-108	156-160	61.4-62.9	84-88	33.0-34.6	68-72	26.7-28.3	84-88	33.0-34.6
	S	47-56	103-123	160-164	62.9-64.5	88-92	34.6-36.2	72-76	28.3-29.9	88-92	34.6-36.2
	M	54-63	119-138	164-168	64.5-66.1	92-96	36.2-37.7	76-80	29.9-31.4	92-96	36.2-37.7
	MP	61-70	134-154	164-168	64.5-66.1	96-100	37.7-39.3	80-84	31.4-33.0	96-100	37.7-39.3
	L	61-70	134-154	168-172	66.1-67.7	96-100	37.7-39.3	80-84	31.4-33.0	96-100	37.7-39.3
	LP	68-77	149-169	168-172	66.1-67.7	100-104	39.3-40.9	84-88	33.0-34.6	100-104	39.3-40.9
	XL	68-77	149-169	172-178	67.7-70.0	100-104	39.3-40.9	84-88	33.0-34.6	100-104	39.3-40.9
	XLP	77-89	169-196	172-178	67.7-70.0	104-108	40.9-42.5	88-92	34.6-36.2	104-108	40.9-42.5
	XXL	77-89	169-196	176-180	69.2-70.8	104-108	40.9-42.5	88-92	34.6-36.2	108-116	40.9-42.5

**KID WETSUITS | TRAJES PARA NIÑOS**

SIZE/AGE TALLA/EDAD	HEIGHT ALTURA		CHEST PECHO		WAIST CINTURA		HIPS CADERAS	
	cm	in	cm	in	cm	in	cm	in
XS/5	115-125	45.2-49.2	67-71	26.3-27.9	53-57	20.8-22.4	64-68	25.1-26.7
S/7	125-135	49.2-53.1	72-76	28.3-29.9	57-61	22.4-24.0	69-73	27.1-28.7
M/9	135-145	53.1-57.0	77-81	30.3-31.8	61-65	24.0-25.5	74-78	29.1-30.7
L/11	145-155	57.0-61.0	82-86	32.2-33.8	65-69	25.5-27.1	79-83	31.1-32.6
XL/13	155-165	61.0-64.9	87-91	34.2-35.8	69-74	27.1-29.1	84-88	33.0-34.6



## Fins | Aletas

SEAC® fins are the result of meticulous design work by our in-house designers both on short- and long-blade fins, with products dedicated to swimming, snorkeling, freediving, and especially scuba. Either open- or closed-foot, they are designed for consistent comfort and flexibility, and to deliver the very best thrust optimization in every kick.

Las aletas SEAC® son el resultado de un meticuloso trabajo de diseño realizado por nuestros diseñadores, tanto en lo que se refiere a aletas de pala corta como a las de pala larga, con productos para natación, la práctica de esnórquel, buceo de apnea y, especialmente, para realizar buceo con botella. Con talón abierto o cerrado, ambos modelos se han diseñado para ofrecer una comodidad y flexibilidad siempre constantes, y garantizar la mejor optimización de propulsión en cada aleteo.





# PROPULSION S | PROPULSION

MADE IN ITALY



4 pieces/unit  
4 unidades/código



- Blade material: polyolefin thermoplastic with special formula.
- Foot pocket material: thermoplastic elastomer.
- Strap: with Sling Strap System, color coordinated with the blade (Propulsion S).
- Strap: with thick strap (Propulsion).
- Weight (single fin): 980 g.
- Other features: ribbing in dual material. Water channels.

- Material de la pala: termoplástico de poliolefina con fórmula especial.
- Material de la cavidad para el pie: elastómero termoplástico.
- Correa: con sistema Sling Strap, color combinado con la pala (Propulsion S).
- Correa: correa gruesa (Propulsion)
- Peso (una sola aleta): 980 g.
- Otras Prestaciones: ribeteado en dos materiales. Canales para el agua.

Coordinated color  
Color combinado

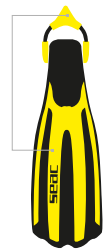

	PROPULSION S			PROPULSION		
SIZE   TALLA	S/M	M/L	L/XL	S/M	M/L	L/XL
SIZE   TALLA (EU)	37/39	40/42	43/45	37/39	40/42	43/45
☐ WHITE	71-43W/S-M	71-43W/M-L	71-43W/L-XL	-	-	-
■ BLUE	71-43B/S-M	71-43B/M-L	71-43B/L-XL	71-12B/S-M	71-12B/M-L	71-12B/L-XL
■ YELLOW	71-43Y/S-M	71-43Y/M-L	71-43Y/L-XL	71-12Y/S-M	71-12Y/M-L	71-12Y/L-XL
■ BLACK	71-43N/S-M	71-43N/M-L	71-43N/L-XL	71-12N/S-M	71-12N/M-L	71-12N/L-XL
■ PINK	-	-	-	71-12P/S-M	71-12P/M-L	-

# F1 S | F1

ITALIAN DESIGN



4 pieces/unit  
4 unidades/código

scuba | 2020

- Blade material: high-performance compound of Ultralight Flex technopolymers with excellent impact resistance, even at low temperatures.
- Foot pocket material: combinations of technopolymer and thermoplastic elastomer.
- Strap: with Sling Strap System, color coordinated with the blade (F1S).
- Strap: with thick strap (F1).
- Weight (single fin): 730 g.
- Other features: Sling Strap System. Protections on the ribbing to guarantee long-lasting durability. Non-slip sole on the foot pocket.

- Material de la pala: compuesto de alto rendimiento en tecnopolímeros Ultralight Flex, con excelente resistencia al impacto, incluso en temperaturas bajas.
- Material de la cavidad para el pie: combinaciones de tecnopolímero elastómero termoplástico.
- Correa: con sistema Sling Strap, color combinado con la pala (F1S).
- Correa: correa gruesa (F1).
- Peso (una sola aleta): 730 g.
- Otras prestaciones: sistema Sling Strap. Protecciones en el ribeteado para garantizar una larga durabilidad. Suela antideslizante en la parte de la cavidad para el pie.

Coordinated color  
Color combinado



	F1 S				F1			
SIZE   TALLA	XS/S	S/M	M/L	L/XL	XS/S	S/M	M/L	L/XL
SIZE   TALLA (EU)	34/36	37/39	40/42	43/45	34/36	37/39	40/42	43/45
■ BLACK	71-36N/XS-S	71-36N/S-M	71-36N/M-L	71-36N/L-XL	71-37B/XS-S	71-37B/S-M	71-37B/M-L	71-37B/L-XL
■ BLACK/BLUE	71-36B/XS-S	71-36B/S-M	71-36B/M-L	71-36B/L-XL	71-37N/XS-S	71-37N/S-M	71-37N/M-L	71-37N/L-XL
■ BLACK/YELLOW	71-36Y/XS-S	71-36Y/S-M	71-36Y/M-L	71-36Y/L-XL	-	-	-	-
■ BLACK/RED	71-36R/XS-S	71-36R/S-M	71-36R/M-L	71-36R/L-XL	71-37R/XS-S	71-37R/S-M	71-37R/M-L	71-37R/L-XL
■ WHITE/PINK	71-36WP/XS-S	71-36WP/S-M	71-36WP/M-L	71-36WP/L-XL	-	-	-	-
■ WHITE/AQUA	71-36WAZ/XS-S	71-36WAZ/S-M	71-36WAZ/M-L	71-36WAZ/L-XL	-	-	-	-



# GP100 S

MADE IN ITALY



4 pieces/unit  
4 unidades/código

scuba | 2020



Coordinated color  
Color combinado

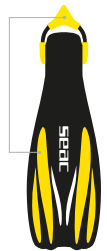

- Blade material: high-performance technopolymer.
  - Foot pocket material: thermoplastic elastomer.
  - Strap: with Sling Strap System (GP100 S).
  - Strap: with thick strap (GP100).
  - Weight (single fin): 1.250 g.
  - Other features: non-slip covering on foot pocket sole.
  - Elastomer coating on the blade to prevent wear and abrasions. Extremely durable fin, ideal military use and/or in extreme conditions.
  - Negative fin promotes better posture by eliminating the positive thrust that in some cases can be created in the footpockets.
- Material de la pala: tecnopolímero de alto rendimiento.
  - Material de la cavidad para el pie: elastómero termoplástico.
  - Correa: con sistema Sling Strap (GP100 S).
  - Correa: correa gruesa (GP100).
  - Peso (una sola aleta): 1,250 g.
  - Otras prestaciones: recubrimiento anti deslizante en la suela de los escarpines. Capa de elastómero en la pala para evitar el desgaste y las abrasiones. Aleta extremadamente duradera, ideal para uso en el ámbito militar y/o en condiciones extremas.
  - La aleta negativa promueve una mejor postura eliminando la propulsión positiva que, en algunos casos, se origina en la cavidad para el pie.

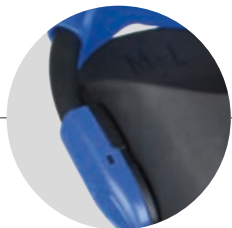

GP100 S					
SIZE   TALLA	XS/S	S/M	M/L	L/XL	XL/XXL
SIZE   TALLA (EU)	34/36	37/39	40/42	43/45	46/48
<input type="checkbox"/> WHITE	71-38W/XS-S	71-38W/S-M	71-38W/M-L	71-38W/L-XL	71-38W/XL-XXL
<input type="checkbox"/> BLUE	71-38B/XS-S	71-38B/S-M	71-38B/M-L	71-38B/L-XL	71-38B/XL-XXL
<input type="checkbox"/> YELLOW	71-38Y/XS-S	71-38Y/S-M	71-38Y/M-L	71-38Y/L-XL	71-38Y/XL-XXL
<input type="checkbox"/> BLACK	71-38N/XS-S	71-38N/S-M	71-38N/M-L	71-38N/L-XL	71-38N/XL-XXL
<input type="checkbox"/> RED	71-38R/XS-S	71-38R/S-M	71-38R/M-L	71-38R/L-XL	71-38R/XL-XXL

## F 100 PRO

MADE IN ITALY



- Blade material: technopolymer with high modulus of elasticity.
- Foot pocket material: thermoplastic rubber.
- Weight (single fin): 748 g.
- Other features: Rubber inserts on the blade to prevent wear and abrasions. New ergonomically shaped foot pocket. Inserts in a third material on the blade to optimize snap.

- Material de la pala: tecnopolímero con un módulo de elasticidad.
- Material de la cavidad para el pie: goma termoplástica.
- Peso (una sola aleta): 748 g.
- Otras prestaciones: inserciones de goma en la pala para evitar el desgaste y las abrasiones. Nueva cavidad para el pie, modelada ergonómicamente. Inserciones en un tercer material en la pala para optimizar cada aleteo.



SIZE   TALLA	36/37	38/39	40/41	42/43	44/45	46/47
☐ WHITE	71-1W/36-37	71-1W/38-39	71-1W/40-41	71-1W/42-43	71-1W/44-45	71-1W/46-47
■ BLUE	71-1B/36-37	71-1B/38-39	71-1B/40-41	71-1B/42-43	71-1B/44-45	71-1B/46-47
■ YELLOW	71-1Y/36-37	71-1Y/38-39	71-1Y/40-41	71-1Y/42-43	71-1Y/44-45	71-1Y/46-47
■ BLACK	71-1N/36-37	71-1N/38-39	71-1N/40-41	71-1N/42-43	71-1N/44-45	71-1N/46-47
■ PINK	71-1P/36-37	71-1P/38-39	71-1P/40-41	-	-	-
■ RED	71-1R/36-37	71-1R/38-39	71-1R/40-41	71-1R/42-43	71-1R/44-45	71-1R/46-47



4 pieces/unit  
4 unidades/código

## FUGA

MADE IN ITALY



- Blade material: technopolymer with high modulus of elasticity.
- Foot pocket material: thermoplastic rubber.
- Weight (single fin): 558 g.
- Other features: water channeling and ridges. External ribbing. High performance technopolymer blade.

- Material de la pala: tecnopolímero con un módulo de elasticidad.
- Material de la cavidad para el pie: goma termoplástica.
- Peso (una sola aleta): 558 g.
- Otras prestaciones: canales para el agua y crestas. Ribeteado externo. Pala de tecnopolímero de alto rendimiento.



SIZE   TALLA	36/37	38/39	40/41	42/43	44/45	46/47
☐ WHITE	71-4W/36-37	71-4W/38-39	71-4W/40-41	71-4W/42-43	71-4W/44-45	71-4W/46-47
■ BLUE	71-4B/36-37	71-4B/38-39	71-4B/40-41	71-4B/42-43	71-4B/44-45	71-4B/46-47
■ YELLOW	71-4Y/36-37	71-4Y/38-39	71-4Y/40-41	71-4Y/42-43	71-4Y/44-45	71-4Y/46-47
■ BLACK	71-4N/36-37	71-4N/38-39	71-4N/40-41	71-4N/42-43	71-4N/44-45	71-4N/46-47
■ RED	71-4R/36-37	71-4R/38-39	71-4R/40-41	71-4R/42-43	-	-



6 pieces/unit  
6 unidades/código

## UNIVERSAL STRAP CORREA UNIVERSAL



Universal fin strap.

Correa universal para aleta.

COD. 512/B

## QRB BUCKLE HEBILLA QRB



Complete fin buckle.

Hebilla integral para aleta.

COD. 73-2

## SLING STRAP



Sling Strap System.

Sistema Sling Strap.

SIZE   TALLA	XS-S	S-M / M-L	M-L / XL-XXL
WHITE	73-23/W-XS	73-23/W-S	73-24/W
BLACK	73-23/N-XS	73-23/N-S	73-24/N
BLUE	73-23/NB-XS	73-23/NB-S	73-24/NB
YELLOW	73-23/NY-XS	73-23/NY-S	73-24/NY
RED	73-23/NR-XS	73-23/NR-S	73-24/NR





# Masks and snorkels | Máscaras y esnórqueles

Our products and their design feature exclusive technological innovation and consistent reliability: these are the founding principles that drive the work of our mask and mouthpiece designers every day at SEAC®. This enables us to offer a wide range of masks and mouthpieces structured to meet any diving need, ranging from a good fit against your face to your comfort and safety.

Nuestros productos y su diseño ofrecen una innovación tecnológica exclusiva y una confiabilidad constante: estos son los principios fundamentales que guían el trabajo que hacen día a día los diseñadores de máscaras y boquillas de SEAC®. Todo esto nos permite ofrecer una amplia gama de máscaras y boquillas pensadas para satisfacer cualquier necesidad en el buceo, empezando por un buen ajuste del rostro que favorezca una mayor comodidad y seguridad.



# ITALICA

MADE IN ITALY



scuba | 2020

S/BL-LS



S/BL



6 pieces/unit  
6 unidades/código

S/KL



- Model: single-lens with wide field of vision.
- Frame: polycarbonate with chrome-plated metal screw seats and stainless steel screws.
- Skirt: soft silicone in differentiated thicknesses, with broad textured surfaces. Areas in contact with the face created to achieve a perfect fit.
- Strap: liquid silicone.
- Lens: Ultra Clear tempered optical glass, 3-mm thick.
- Version LS: with special mirrored lens treatment (increases contrast and visibility) and metal effect frame (special scratch-resistant paint).
- Package: rigid transparent box.
- Other features: skirt in Comfort Silicone. Self-positioning buckle with 3D pivoting system. Ultra Clear or LS version lens with special mirrored treatment.

- Modelo: una sola lente con un campo amplio de visión.
- Montura: policarbonato con lechos de los tornillos hechos en metal cromado y tornillos de acero inoxidable.
- Faldón: silicona suave en distintos grosores, con amplias superficies texturadas. Las áreas en contacto con la cara se han diseñado de un modo tal que permiten obtener un ajuste perfecto de la máscara.
- Tira: silicona líquida.
- Lente: cristal óptico templado Ultra Clear de 3 mm de grosor.
- Embalaje: caja rígida transparente.
- Otras prestaciones: faldón fabricado en silicona Comfort. Hebilla autoposicionable con sistema oscilante en 3D.



MODEL   MODELO	S/BL	S/BL - LS
BLK/METAL CLEAR BLUE	75-53BCM/SBL	-
BLK/METAL BLUE	75-53BM/SBL	75-53BM/SBL-LS
BLK/METAL BLACK	75-53NM/SBL	75-53NM/SBL-LS
BLK/METAL RED	75-53RM/SBL	75-53RM/SBL-LS
BLK/METAL ORANGE	-	75-53OM/SBL-LS
BLK/METAL YELLOW	-	75-53YM/SBL-LS

MODEL   MODELO	S/KL
BLUE	75-53BM/SKL
YELLOW	75-53YM/SKL
BLACK	75-53NM/SKL
RED	75-53RM/SKL
LIMITED EDITION	75-53/SKL-LM





# ITALICA ASIAN FIT



MADE IN ITALY

S/BL-LS



S/BL



S/WH



6 pieces/unit  
6 unidades/código

- Model: single-lens with wide field of vision.
- Frame: polycarbonate with chrome-plated metal screw seats and stainless steel screws.
- Skirt: soft silicone in differentiated thicknesses, with broad textured surfaces. Areas in contact with the face created to achieve a perfect fit. Asian Fit version specially designed for more slender faces.
- Strap: Liquid silicone.
- LS Version: tempered glass lens with special mirrored treatment (increases contrast and visibility) and metal effect frame (special scratch-resistant paint).
- Package: rigid transparent box.
- Other features: Comfort Silicone skirt with Asian fit for narrower faces. Ultra Clear single lens or lens with special mirrored treatment.



S/KL



- Modelo: una sola lente con un campo amplio de visión.
- Montura: policarbonato con lechos de los tornillos hechos en metal cromado y tornillos de acero inoxidable.
- Faldón: silicona suave en distintos grosores, con amplias superficies texturadas. Las áreas en contacto con la cara se han diseñado de un modo tal que permiten obtener un ajuste perfecto de la máscara. Versión Ajuste Asiático especialmente diseñada para rostros más delgados.
- Tira: silicona líquida.
- Versión LS: lente de cristal templado con un tratamiento especial de espejo (aumenta el contraste y la visibilidad) y montura con efecto de metal (pintura especial resistente a los arañazos).
- Embalaje: caja rígida transparente.
- Otras Prestaciones: faldón en silicona Comfort con Ajuste Asiático para caras más estrechas. Lente con tratamiento especial de espejo.



MODEL   MODELO	S/BL	S/BL - LS
BLK/METAL WHITE	-	75-54WM/SBL-LS
BLK/METAL CLEAR BLUE	-	75-54BCM/SBL-LS
BLK/METAL YELLOW	-	75-54YM/SBL-LS
BLK/METAL BLACK	75-54NM/SBL	75-54NM/SBL-LS
BLK/METAL PINK	-	75-54PM/SBL-LS
BLK/METAL RED	75-54RM/SBL	75-54RM/SBL-LS
BLK/METAL ORANGE	-	75-54OM/SBL-LS
BLK/METAL BLUE	-	75-54BM/SBL-LS

MODEL   MODELO	S/KL	S/WH
CLEAR BLUE	75-54BCM/SKL	-
YELLOW	75-54YM/SKL	-
LIMITED EDITION	75-54/SKL-LM	-
WHITE/AQUA	-	75-54A/SWH
WHITE/PINK	-	75-54P/SWH



**ITALIA**

MADE IN ITALY



scuba | 2020

S/BL-LS



S/BL



OPTIONAL OPTICAL LENSES  
-1.0 to -6.0 | +1.0 to +3.0



+45%  
UNDERWATER VISIBILITY

S/KL



6 pieces/unit  
6 unidades/código

- Model: dual-lens with wide field of vision.
- Frame: polycarbonate with chrome-plated metal screw seats and stainless steel screws.
- Skirt: soft silicone in differentiated thicknesses, with broad textured surfaces. Areas in contact with the face created to achieve a perfect fit.
- Strap: Liquid silicone.
- Lenses: Ultra Clear tempered optical glass, 3 mm thick.
- LS Version: with special mirrored lens treatment (increases contrast and visibility) and metal effect frame (special scratch-resistant paint).
- Optical lenses: options include negative -1.0 to -6.0 and positive +1.0 to +3.0.
- Package: rigid transparent box.
- Other features: wide field of vision. Differentiated thickness on the Comfort Silicone skirt. LS Version with special mirrored lens treatment.

- Modelo: una sola lente con un campo amplio de visión.
- Montura: policarbonato con lechos de los tornillos hechos en metal cromado y tornillos de acero inoxidable.
- Faldón: silicona suave en distintos grosores, con amplias superficies texturadas. Las áreas en contacto con la cara se han diseñado de un modo tal que permiten obtener un ajuste perfecto de la máscara.
- Tira: silicona líquida.
- Lente: cristal óptico templado Ultra Clear de 3 mm de grosor.
- Versión LS: con lentes que tienen tratamiento especial de espejo (aumenta el contraste y la visibilidad) y montura con efecto metalizado (pintura especial resistente a los arañazos).
- Embalaje: caja rígida transparente.
- Otras prestaciones: faldón fabricado en silicona Comfort transparente. Lente Ultra Clear o versión LS con un tratamiento especial de espejo.



TEMPERED GLASS



COMFORT SILICONE



HARD METAL COATING



OPTIMIZED LENS INCLINATION

MODEL   MODELO	S/BL	S/BL - LS	MODEL   MODELO	S/KL
BLK/METAL CLEAR BLUE	75-37BCM/SBL	-	BLUE	75-37BM/SKL
BLK/METAL ORANGE	-	75-37OM/SBL-LS	YELLOW	75-37GM/SKL
BLK/METAL BLUE	75-37BM/SBL	75-37BM/SBL-LS	BLACK	75-37NM/SKL
BLK/METAL YELLOW	-	75-37YM/SBL-LS	RED	75-37RM/SKL
BLK/METAL BLACK	75-37NM/SBL	75-37NM/SBL-LS	LIMITED EDITION	75-37/SKL-LM
BLK/METAL RED	75-37RM/SBL	75-37RM/SBL-LS		

# ITALIA ASIAN FIT

MADE IN ITALY



S/BL-LS



S/BL



S/WH



6 pieces/unit  
6 unidades/código



- Model: dual-lens with wide field of vision.
  - Frame: polycarbonate with chrome-plated metal screw seats and stainless steel screws.
  - Skirt: soft silicone in differentiated thicknesses, with broad textured surfaces. Areas in contact with the face created to achieve a perfect fit. Asian Fit version specially designed for more slender faces.
  - Strap: Liquid silicone.
  - LS Version: tempered glass lenses with special mirrored treatment (increases contrast and visibility) and metal effect frame (special scratch-resistant paint).
  - Optical lenses: options include negative -1.0 to -6.0 and positive +1.0 to +3.0.
  - Package: rigid transparent box.
  - Other features: asian faces. 3D Pivoting Buckle system that lets the buckle find the right position. LS Version with special mirrored lens treatment.
- Modelo: una sola lente con un campo amplio de visión.
  - Montura: policarbonato con lechos de los tornillos hechos en metal cromado y tornillos de acero inoxidable.
  - Faldón: silicona suave en distintos grosores, con amplias superficies texturadas. Las áreas en contacto con la cara se han diseñado de un modo tal que permiten obtener un ajuste perfecto de la máscara. Versión Ajuste Asiático especialmente diseñada para rostros más delgados.
  - Tira: silicona líquida.
  - Versión LS: lente de cristal templado con un tratamiento especial de espejo (aumenta el contraste y la visibilidad) y montura con efecto de metal (pintura especial resistente a los arañazos).
  - Embalaje: caja rígida transparente.
  - Otras Prestaciones: faldón en silicona Comfort de color negro con Ajuste Asiático para caras más estrechas. Lente con tratamiento especial de espejo.

S/KL



MODEL   MODELO	S/BL	S/BL - LS	MODEL   MODELO	S/KL	S/WH
BLK/METAL WHITE	-	75-40WM/SBL-LS	CLEAR BLUE	75-40BCM/SKL	-
BLK/METAL CLEAR BLUE	-	75-40BCM/SBL-LS	YELLOW	75-40YM/SKL	-
BLK/METAL YELLOW	-	75-40Y/SBL-LS	LIMITED EDITION	75-40/SKL-LM	-
BLK/METAL BLACK	75-40NM/SBL	75-40NM/SBL-LS	WHITE/AQUA	-	75-40A/SWH
BLK/METAL PINK	-	75-40PM/SBL-LS	WHITE/PINK	-	75-40P/SWH
BLK/METAL RED	75-40RM/SBL	75-40RM/SBL-LS			
BLK/METAL ORANGE	-	75-40OM/SBL-LS			
BLK/METAL BLUE	-	75-40BM/SBL-LS			

# TOUCH



S/COL



- Structure: silicone mounted with "frameless" technology.
- Skirt: liquid silicone with differentiated thicknesses, comfortable, compact, and smaller in volume.
- Lens: single lens in tempered glass.
- Buckles: dual button.
- Design: designed and manufactured in Italy.
- Packaging: transparent rigid box included.
- Other features: opaque colored Comfort Silicone skirt. Frameless technology with reduced internal volume. Strap customized with SEAC® logo.

- Estructura: silicona montada con la tecnología «sin montura».
- Faldón: silicona líquida con diferentes grosores, cómoda, compacta y más pequeña en volumen.
- Lentes: lente única con cristal templado.
- Hebillas: botón doble.
- Diseño: creado y fabricado en Italia.
- Embalaje: incluye una caja rígida transparente.
- Otras prestaciones: faldón de silicona Comfort en color opaco. Tecnología sin montura con volumen interno reducido. Correa personalizada con el logotipo de SEAC®.

MODEL   MODELO	S/COL
■ BLACK	75-55N/SBL
■ BLUE	75-55B/SB
■ YELLOW	75-55Y/SYE
■ PINK	75-55P/SPI
■ GREEN	75-55V/SGR

 6 pieces/unit  
6 unidades/código





# FOX | E-FOX ASIAN FIT



S/BL (FOX)



S/WH



S/KL



S/BL (E-FOX)



- Frame: polycarbonate.
- Skirt: Hypoallergenic Comfort Silicone with differentiated thickness.
- Asian Fit version: Asia Fit with special focus on the nose.
- Strap: silicone.
- Lenses: symmetrical in tempered glass.
- Optical lenses: options from -1.0 to -6.0.
- Packaging: transparent rigid box included.
- Other features: differentiated thickness on the Comfort Silicone skirt. Buckle folds to occupy less space. Smooth Edges to maximize comfort against your face.

- Montura: policarbonato.
- Faldón: silicona Comfort hipoalergénica con grosores diferenciados.
- Tira: silicona.
- Lentes: simétricos en cristal templado.
- Lente óptica: opciones de -1,0 a -6,0.
- Embalaje: incluye una caja rígida transparente.
- Otras prestaciones: grosor diferenciado en un faldón hecho de silicona Comfort. La hebilla se dobla para ocupar menos espacio. Sistema Smooth Edges para maximizar la comodidad al contacto con la cara.



MODEL   MODELO	FOX			E-FOX ASIAN FIT	
	S/KL	S/BL	S/WH	S/BL	S/WH
AQUAMARINE	75-31A/SKL	-	-	-	-
BLACK	75-31N/SKL	75-31N/SBL	-	-	-
BLK/METAL RED	-	75-31NRM/SBL	-	-	-
BLK/METAL BLUE	75-31BM/SKL	75-31NBM/SBL	-	75-32NBL/SBL	-
WHITE/AQUAMARINE	-	-	75-31A/SWH	-	75-32A/SWH
WHITE/PINK	-	-	75-31P/SWH	-	75-32P/SWH



6 pieces/unit  
6 unidades/código

# ONE



S/KL ONE



S/KL ONE BOX 20 PCS



S/KL ONE

S/KL ONE BOX 20 PCS



- Frame: polycarbonate.
- Skirt: high-quality hypoallergenic liquid silicone.
- Strap: silicone.
- Lenses: in tempered glass.
- Optical lenses: options from -1.0 to -6.0.
- Buckle on the frame with Easy Touch system.
- Option to mount optical lenses.

- Montura: policarbonato.
- Faldón: silicona líquida hipoalergénica.
- Tira: silicona.
- Lentes: en cristal templado.
- Lente óptica: opciones de -1,0 a -6,0.
- Hebilla en la montura con el sistema Easy Touch.
- Opción para cambiar a lente óptica.



Package of 6 per code in all color options.  
Option for 20-piece pack for ONE S/KL GREY (COD. DE9448N) in soft box.

Paquete de 6 unidades por código en todas las opciones de colores.  
Opción de paquete de 20 piezas para ONE S/KL GREY (COD. DE9448N) en una caja blanda.

MODEL   MODELO	ONE S/KL	ONE BOX 20 PCS S/KL
BLUE	9448B	-
CLEAR BLUE	9448BC	-
YELLOW	9448Y	-
BLACK	9448N	DE9448N



# ONE PRO



- Frame: polycarbonate.
- Skirt: high-quality hypoallergenic liquid silicone.
- Strap: silicone.
- Lenses: in tempered glass.
- Optical lenses: options from -1.0 to -6.0.
- Packaging: transparent rigid box included.
- Action Cam mount.
- Buckle on the frame with Easy Touch system.
- Option to mount optical lenses.

- Montura: policarbonato.
- Faldón: silicona líquida hipoalergénica.
- Tira: silicona.
- Lentes: en cristal templado.
- Lente óptica: opciones de -1,0 a -6,0.
- Embalaje: incluye una caja rígida transparente.
- montaje para cámara de acción.
- Hebilla en la montura con el sistema Easy Touch.
- Opción para cambiar a lente óptica.



OPTIONAL OPTICAL LENSES  
-1.0 to -6.0



TEMPERED GLASS



PURE SILICONE

MODEL   MODELO	S/KL	S/BL
CLEAR BLUE	75-56BC/SKL	-
BLACK	75-56N/SKL	75-56N/SBL



6 pieces/unit  
6 unidades/código

# EXTREME

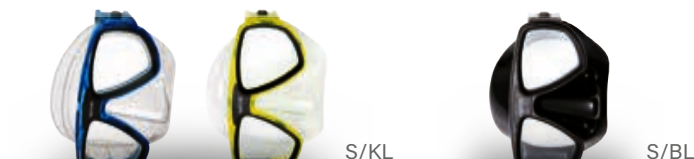

- Frame: polycarbonate.
- Skirt: hypoallergenic liquid silicone.
- Strap: silicone.
- Lenses: in tempered glass.
- Optical lenses: options from -1.0 to -6.0.
- Other features: buckle on the skirt featuring the Tubing Connected System that ensures a secure seal and minimizes the pressure of the mask against your face.
- Anatomical skirt in high-quality liquid silicone.
- Option to mount optical lenses.

- Montura: policarbonato.
- Faldón: silicona líquida hipoalergénica.
- Tira: silicona.
- Lentes: en cristal templado.
- Lente óptica: opciones de -1,0 a -6,0.
- Otras prestaciones: hebilla en el faldón que incorpora el sistema Tubing Connected para garantizar un sellado seguro y que minimiza la presión de la máscara contra la cara. Faldón anatómico en silicona líquida de gran calidad. Opción para cambiar a lente óptica.



OPTIONAL OPTICAL LENSES  
-1.0 to -6.0



DIVING CENTER



TEMPERED GLASS



PURE SILICONE

MODEL   MODELO	S/KL	S/BL
CLEAR BLUE	75-33BC/SKL	-
YELLOW	75-33Y/SKL	-
BLACK	-	75-33N/SBL



6 pieces/unit  
6 unidades/código



### LENS REPLACEMENT TOOL HERRAMIENTA PARA RECAMBIO DEL LENTE



COD. 0780018

### MASK BOX | CAJA PARA MÁSCARA



COD. 111-95

### ANTI-FOG BIO GEL

MADE IN ITALY

24 pieces/unit  
24 unidades/código



### MASK STRAP TIRA PARA MÁSCARA



Liquid silicone strap. 16 mm.

Tira hecha de silicona líquida. 16 mm.

VERSION   VERSIÓN	15 ml	30 ml
COD.	111-99	1608

VERSION   VERSIÓN	S/KL	S/BL	S/BL LOGO
COD.	78-12	78-13	0780017

### ACTION CAM ADAPTER FOR ONE ADAPTADOR ACTION CAM PARA ONE

Action cam adapter for ONE mask.

Adaptador para action cam para máscara ONE.



COD. 0780019

### OPTICAL LENSES | LENTES RECETADOS

DIOPTRIES   DIOPTRÍAS	- 1	- 1.5	- 2	- 2.5	- 3	- 3.5	- 4	- 4.5
EXTREME	2601	2602	2603	2604	2605	2606	2607	2608
ONE DX   ONE RIGHT	2661/D	2662/D	2663/D	2664/D	2665/D	2666/D	2667/D	2668/D
ONE SX   ONE LEFT	2661/S	2662/S	2663/S	2664/S	2665/S	2666/S	2667/S	2668/S
FOX / E-FOX ASIAN FIT	80-14/-1,0	80-14/-1,5	80-14/-2,0	80-14/-2,5	80-14/-3,0	80-14/-3,5	80-14/-4,0	80-14/-4,5
ITALIA DX   ITALIA RIGHT	80-15D/-1,0	80-15D/-1,5	80-15D/-2,0	80-15D/-2,5	80-15D/-3,0	80-15D/-3,5	80-15D/-4,0	80-15D/-4,5
ITALIA SX   ITALIA LEFT	80-16S/-1,0	80-16S/-1,5	80-16S/-2,0	80-16S/-2,5	80-16S/-3,0	80-16S/-3,5	80-16S/-4,0	80-16S/-4,5

DIOPTRIES   DIOPTRÍAS	- 5	- 5.5	- 6	+ 1	+ 1.5	+ 2	+ 2.5	+ 3
EXTREME	2609	2610	2611	-	-	-	-	-
ONE DX   ONE RIGHT	2669/D	2670/D	2671/D	-	-	-	-	-
ONE SX   ONE LEFT	2669/S	2670/S	2671/S	-	-	-	-	-
FOX / E-FOX ASIAN FIT	80-14/-5,0	80-14/-5,5	80-14/-6,0	-	-	-	-	-
ITALIA DX   ITALIA RIGHT	80-15D/-5,0	80-15D/-5,5	80-15D/-6,0	80-15D/+1,0	80-15D/+1,5	80-15D/+2,0	80-15D/+2,5	80-15D/+3,0
ITALIA SX   ITALIA LEFT	80-16S/-5,0	80-16S/-5,5	80-16S/-6,0	80-16S/+1,0	80-16S/+1,5	80-16S/+2,0	80-16S/+2,5	80-16S/+3,0

# VORTEX DRY

ITALIAN DESIGN

S/BL

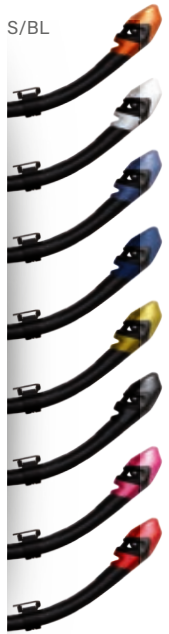

S/KL



## QUICK SNORKEL RETAINER RETENEDOR RAPIDO DE SNORKEL



COD. 0870009

Universal, for all snorkel types

Universal, para todos los tipos de tubos de esnórquel



12 pieces/unit  
12 unidades/código

- Model: black or clear silicone snorkel with dry top system and purge valve.
- Mouthpiece: in liquid silicone.
- Tube: plastic material.
- Corrugated: in liquid silicone.

- Modelo: esnórquel de silicona negra con el sistema Dry Top y válvula de purga.
- Boquilla: de silicona líquida.
- Tubo: material plástico
- Manguera: de silicona líquida corrugada.

MODEL   MODELO	S/BL	MODEL   MODELO	S/KL
BLACK/ORANGE	84-22OM/SBL	AQUAMARINE	84-22A/SKL
BLACK/WHITE	84-22W/SBL	WHITE	84-22W/SKL
BLACK/CLEAR BLUE	84-22BC/SBL	WHITE/AQUAMARINE	84-22WA/SKL
BLACK/METALLIC BLUE	84-22BM/SBL	WHITE/PINK	84-22WP/SKL
BLACK/YELLOW	84-22Y/SBL	BLUE	84-22B/SKL
BLACK	84-22N/SBL	YELLOW	84-22Y/SKL
BLACK/PINK	84-22P/SBL	PINK	84-22P/SKL
BLACK/METALLIC RED	84-22RM/SBL		



# FAST TECH DRY

ITALIAN DESIGN

S/KL



S/BL



12 pieces/unit  
12 unidades/código

- Model: clear or black silicone snorkel with dry top system and purge valve.
- Mouthpiece: liquid silicone.
- Tube: plastic material.
- Other features: ABS body with liquid silicone corrugated hose; purge valve.

- Modelo: esnórquel de silicona negra o transparente con el sistema Dry Top y válvula de descarga.
- Boquilla: silicona líquida.
- Tubo: material plástico con manguera de silicona líquida corrugada.
- Otras prestaciones: manguera de silicona líquida corrugada, negra o transparente. Válvula de descarga. Válvula seca.

FAST TECH DRY			
MODEL   MODELO	S/KL	S/BL	
AQUAMARINE	84-32A/SKL	-	
WHITE	84-32W/SKL	-	
BLUE	84-32B/SKL	-	
YELLOW	84-32Y/SKL	-	
PINK	84-32P/SKL	-	
BLACK	-	84-32N/SBL	
BLACK/WHITE	-	84-32NW/SBL	





# VORTEX

ITALIAN DESIGN



12 pieces/unit  
12 unidades/código

S/KL



S/BL



- Model: Snorkel with anti-splash top and purge valve.
- Mouthpiece: liquid silicone.
- Tube: body in plastic technopolymer with corrugated in liquid silicone and polycarbonate ends.
- Other features: purge valve. Anti-splash top.

- Modelo: tubo de esnórquel con sistema antisalpicaduras en la parte superior y válvula de descarga.
- Boquilla: silicona líquida.
- Tubo: cuerpo en tecnopolímero plástico con manguera en silicona líquida y extremos de policarbonato.
- Otras prestaciones: válvula de descarga. Parte superior antisalpicaduras.

MODEL   MODELO	S/KL	S/BL
<input type="checkbox"/> WHITE	84-1W/SKL	-
<input type="checkbox"/> BLUE	84-1B/SKL	-
<input type="checkbox"/> CLEAR BLUE	84-1BC/SKL	-
<input type="checkbox"/> TRANSPARENT	84-16T/SKL	-
<input checked="" type="checkbox"/> BLACK/RED	-	84-16NR/SBL

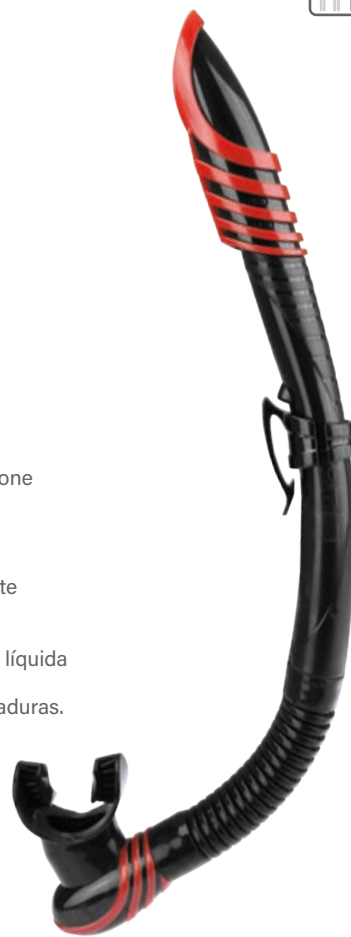

# FAST TECH

ITALIAN DESIGN



12 pieces/unit  
12 unidades/código

S/KL



FAST SNORKEL RETAINER  
RETENEDOR DE SNORKEL FAST  
COD. 214N

- Model: Snorkel with anti-splash top and purge valve.
- Mouthpiece: silicone.
- Tube: ABS body with liquid silicone corrugated hose.

- Modelo: tubo de esnórquel con sistema antisalpicaduras en la parte superior y válvula de descarga.
- Boquilla: silicona.
- Tubo: cuerpo ABS con tubo corrugado de silicona líquida.

MODEL   MODELO	S/KL
<input checked="" type="checkbox"/> BLUE	476B
<input checked="" type="checkbox"/> YELLOW	476G
<input checked="" type="checkbox"/> BLACK	476N
<input checked="" type="checkbox"/> RED	476R



# LIQUID

ITALIAN DESIGN



12 piezas/unit  
12 unidades/código

The differentiated cross section tube is designed to ensure excellent breathing and allow the diver to expel water quickly and efficiently. We chose 100% silicone for two main reasons: it's the only material that doesn't change its characteristics or its behavior based on the temperature, and it has sufficient memory to recover its original shape even after being deformed for long periods.

El tubo de sección diferenciada ha sido estudiado para garantizar una óptima respiración y para permitir la expulsión del agua de manera rápida y eficaz. La razón por la que se ha utilizado 100 % silicona se debe, esencialmente, a dos aspectos: es el único material que no cambia sus características y su comportamiento según cuál sea la temperatura e, igualmente, por mucho que se deforme durante largos períodos, conserva la memoria para volver a recuperar su forma original.

MODEL   MODELO	S/KL	S/BL	S/COL
RED	-	-	84-23R/SR
BLUE	-	-	84-23B/SB
BLACK	-	84-23N/SBL	-
TRANSPARENT	84-12T/SKL	-	-



# JET

ITALIAN DESIGN



12 piezas/unit  
12 unidades/código

- Model: anatomically shaped snorkel.
- Mouthpiece: silicone.
- Tube: plastic technopolymer.

- Modelo: esnórquel modelado anatómicamente.
- Boquilla: silicona.
- Tubo: tecnopolímero de plástico.

MODEL   MODELO	S/KL	S/BL	S/COL
BLUE	483B	-	486B
BLACK	483N	484N	-
TRANSPARENT	483T	-	-
BROWN	-	-	487M
GREEN	-	-	488V

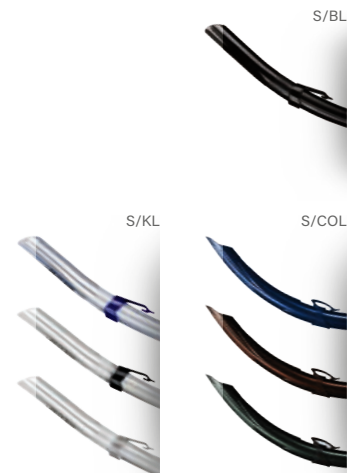



# Knives | Cuchillos

SEAC® offers a wide range of dive knives made with tempered stainless steel blades to ensure the most reliable possible knife for both quality and performance.

SEAC® ofrece una amplia gama de cuchillos de buceo fabricados a partir de hojas de acero inoxidable templado para garantizar un producto final de un cuchillo lo más fiable posible tanto en calidad como en rendimiento.





# TITANIUM

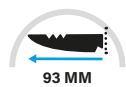

STRAPS INCLUDED  
CORREAS INCLUIDAS

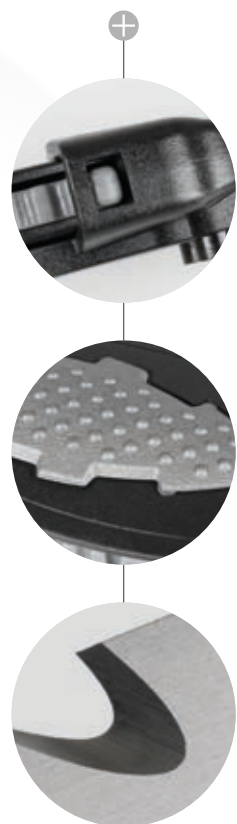

Serrated edge titanium blade. Very lightweight.  
"Double Release System" lets you pull the knife out one-handed.  
It can be fastened to the weight belt, arm, or calf.

Hoja de titanio con borde serrado. Muy ligero.  
Sistema de liberación doble, que le permite jalar del cuchillo con una sola mano.  
Se puede ajustar al cinturón de lastre, al brazo o a la pantorrilla.

COD. 55-22/N

## RAPID

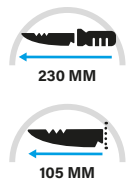

AISI 420 tempered steel blade with line cutter.  
Shock-proof plastic sheath with updated Easy Lock system.  
Dual-material ergonomic handle with end-cap hammer.

Hoja de acero templado AISI 420 con cortador de línea.  
Vaina de plástico a prueba de impactos, con sistema Easy Lock actualizado.  
Empuñadura ergonómica de material doble, con mazo al final de la empuñadura.

COD. 55-23/NO



STRAPS INCLUDED  
CORREAS INCLUIDAS

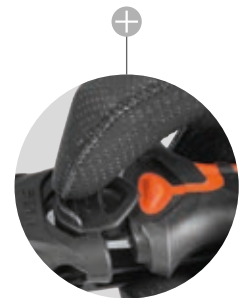

## RAPID DAGA

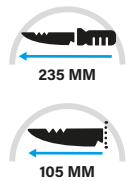

AISI 420 tempered steel blade. Typical stiletto shape.  
Dual-material ergonomic handle with end-cap hammer. Sheath with Easy Lock system.  
Reversible fastening.  
It can be fastened to the weight belt, arm, or calf.

Hoja de acero templado AISI 420. Forma típica tipo estilete.  
Empuñadura ergonómica de material doble, con mazo al final de la empuñadura. Vaina con sistema Easy Lock.  
Ajuste reversible.  
Se puede ajustar al cinturón de lastre, al brazo o a la pantorrilla.

COD. 55-24/NG



STRAPS INCLUDED  
CORREAS INCLUIDAS

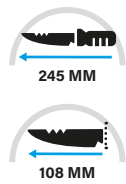

## HAMMER

STRAPS INCLUDED  
CORREAS INCLUIDAS

Dive knife with AISI 420 tempered stainless steel blade and a stainless steel end-cap hammer at the end of the grip. Blade 120 mm long, with straight edge on one side and serrated edge + line cutter on the other. Grip over-molded with soft thermoplastic rubber providing a non-slip surface for a safe grip. Reversible attachment so you can keep your knife on either side. A hole for fastening the line is provided at the end of the grip. Rigid sheath with large knife release button in the center.

Cuchillo de buceo con hoja de acero inoxidable AISI 420 templado y mazo de acero inoxidable al final de la empuñadura. Hoja de 120 mm de largo, con un borde recto por una parte y sierra en la otra, además de un cúter para cortar hilos. Empuñadura sobremoldeada en goma termoplástica suave que le aporta un efecto antideslizante para un agarre más seguro. Conexión reversible, para fijar el cuchillo en cualquiera de los dos costados. En el extremo de la empuñadura dispone de un orificio para sujetar la línea. Vaina rígida con gran botón de sujeción del cuchillo en el centro.

COD. 55-17/N

## SHARP

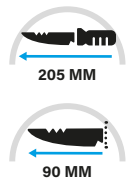
STRAPS INCLUDED  
CORREAS INCLUIDAS**NEW**

Stiletto-shaped blade and serrated edge. "Double Release System" lets you pull the knife out one-handed. Can be fastened to the arm or calf. Reversible fastening.

Hoja de forma típica tipo estilete y borde con sierra. Sistema de liberación doble, que le permite jalar del cuchillo con una sola mano. Se puede ajustar al brazo o a la pantorrilla. Ajuste reversible.

COD. 55-25/NG



## BAT

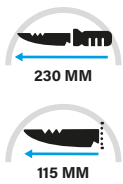

AISI 420 tempered steel blade. 12-cm blade with a serrated edge and a line cutter. Overmoulded handle for a more secure grip. Release button in the handle. Rigid case.

Hoja de acero templado AISI 420. Hoja de 12 cm con un borde con sierra y cortador de línea. Empuñadura sobremoldeada para brindar un agarre más seguro. Botón de liberación en la empuñadura. Carcasa rígida.

BAT		
	RED	55-18/R
	GREEN	55-18/V

## TAJAMAN

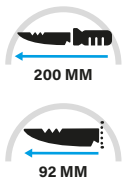

One-piece dive knife with protective black Teflon coating. 95-mm tempered stainless steel AISI 420 dual-cut blade, smooth and serrated, with line cutter. Length 200 mm. Safety grip on both sides of the handle. Ultra-resistant fabric scabbard with Velcro closure. Fastens with two straps, included.

Cuchillo de buceo hecho en una zona pieza, con recubrimiento protector de Teflon negro. Hoja de corte dual de acero inoxidable AISI 420 de 95 mm, lisa y tipo serrucho, con cortador de línea. Longitud de 200 mm. Empuñadura de seguridad en ambos lados del mango. Funda hecha en tela ultra resistente, con cierre de Velcro. Se ajusta con dos correas, que están incluidas.

COD. 55-21/N

## DEVIL HD

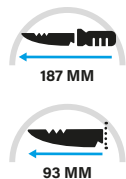

STRAPS INCLUDED  
CORREAS INCLUIDAS



Knife with special tempered stainless steel blade, with stiletto shape designed specifically for underwater spearfishing. Excellent penetration and cutting ability on both edges, straight and serrated. Click sheath with Push & Pull Out system that can be operated one-handed, even when wearing gloves.

Cuchillo con una hoja en acero inoxidable templado especial y una forma tipo estilete diseñada específicamente para la práctica de la pesca submarina. Penetración excelente y, al integrar un lado recto y otro con sierra, permite cortar por ambos costados. Vaina de clic con sistema Push & Pull Out que permite manipularse con una sola mano, incluso con los guantes puestos.

COD. 55-20/N

## SAMURAI

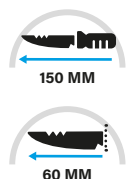

Tempered and polished stainless steel blade for maximum resistance to corrosion.

Hoja de acero inoxidable templado y pulido para una resistencia máxima a la corrosión.

SAMURAI	
WHITE	55-16/W
BLACK	55-16/N
RED	55-16/R
GREEN	55-16/V



## K-JACK

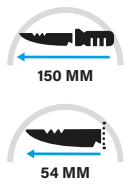

Stainless steel blade fitted with built-in line cutter. Dual-material ergonomic handle. Shockproof plastic sheath with asymmetrical Easy Lock button closure system.

Hoja de acero inoxidable con cúter integrado. Asa ergonómica fabricada en dos materiales. Vaina de plástico resistente a los golpes y sistema de cierre con botón asimétrico Easy Lock.

COD. 55-19

## KNIFE STRAPS | CORREAS DE SUJECIÓN PARA CUCHILLOS

Pair of knife straps with stainless steel buckle.

Par de correas de sujeción para cuchillo con hebilla en acero inoxidable.

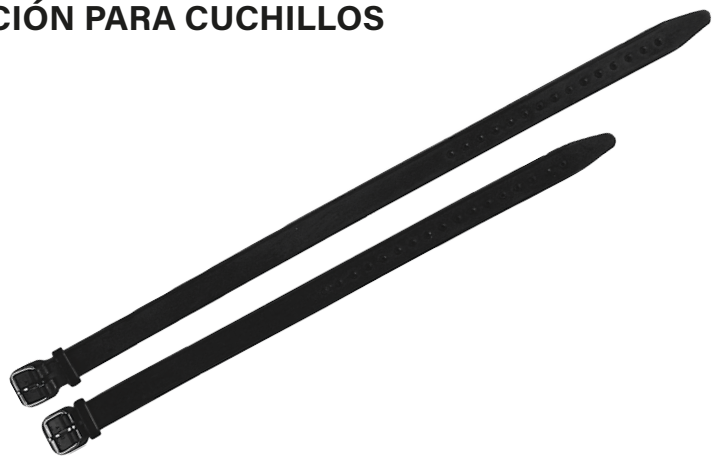

COD. 049/C

## KNIFE STRAP | ANILLA DE SUJECIÓN PARA CUCHILLO

Universal knife strap ring.

Anilla universal para la sujeción del cuchillo.



SIZE | TALLA

SMALL | PEQUEÑO

LARGE | GRAN

COD.

050/B

050





seac

EQUIPAGE  
1000

(140)  
(L)



# Bags and accessories | Bolsas y accesorios

Every diver knows there is a big difference between a bag marketed as good for diving and a bag conceived and designed for the needs of an actual diver. Roominess and weight capacity, the sturdiness of the materials and details, breathable and waterproof fabrics, logically-designed and compact shapes, convenient transport with easy access to the compartments, and a full range of accessories and functions are only some of the most important characteristics. At SEAC® we pay as just much attention to our unique and exclusive trolley system. It's convenient and functional, compact, and incredibly sturdy.

Todos los buceadores saben que existe una gran diferencia entre una bolsa comercializada como buena para bucear y una bolsa concebida y diseñada para cubrir las necesidades de un buceador de verdad. La capacidad de espacio y para soportar peso, la robustez de los materiales y sus detalles, el tejido transpirable e impermeable, formas compactas diseñadas con sentido de la lógica, transporte práctico con un fácil acceso a los compartimentos y una gama completa de accesorios y funciones, son solo algunas de las características más importantes. En SEAC® prestamos la misma atención al sistema único y exclusivo de nuestros trolley. Es práctica y funcional, compacta e increíblemente robusta.



NEW

## EQUIPAGE 1000



- Material: Polyester 1200D - Tarpaulin - Heat formed EVA.
- Rigid rear panel in heat-formed EVA.
- Telescoping handle (50 cm).
- Primary compartment with two pockets for holding suit and boots.
- Rugged wheels.
- D-Ring on the rear panel.
- Front pocket.
- Dimensions: 75x42x38 cm.
- Volume: 140 lt max.

- Material: Poliéster de 1200D - Lona - EVA termoformada.
- Panel trasero rígido en EVA termoformada.
- Manija telescópica (50 cm).
- Compartimento principal con dos bolsillos para llevar el traje y las botas.
- Ruedas resistentes.
- Anilla D en el panel trasero.
- Bolsillo delantero.
- Dimensiones: 75x42x38 cm.
- Volumen: Máximo 140 litros.

COD. 92-24



## EQUIPAGE 500

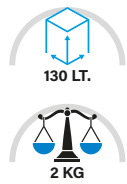

NEW

- Material: 600D polyester and Tarpaulin.
- Fin pocket with drainage system.
- Rugged wheels.
- Adjustable padded shoulder strap, belly fastening.
- Upper handle.
- Dimensions: 85x40x35 cm.
- Volume: 130 lt max.

- Material: Poliéster de 600D y lona.
- Bolsillo para las aletas con sistema de drenaje.
- Ruedas resistentes.
- Correa para el hombro ajustable y acolchada, con correa de ajuste para el abdomen.
- Manija superior.
- Dimensiones: 85x45x33 cm.
- Volumen: Máximo 130 litros.



COD. 92-25/500

## EQUIPAGE 250



NEW

- Material: 600D Polyester.
- Adjustable shoulder strap.
- Fin pocket with buckle.
- Front pocket.
- Dimensions: 75x40x35 cm.
- Volume: 110 lt max.

- Material: poliéster 600D.
- Correa ajustable para el hombro.
- Bolsillo para las aletas con hebilla.
- Bolsillo delantero.
- Dimensiones: 77x47x35 cm.
- Volumen: Máximo 110 litros.

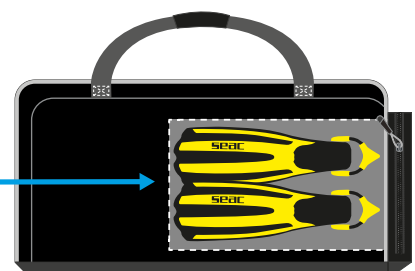
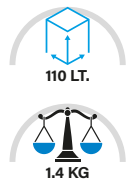

COD. 92-25/250

## MATE NET

NEW



- Material: 600D Polyester.
- Mesh bag.
- Side compartment.
- Dimensions: 70x45x30 cm.

- Material: poliéster 600D.
- Bolsa de red.
- Compartimento lateral.
- Dimensiones: 70x45x30 cm.

COD. 92-25/NET

## KUF



NEW

- Ultra-light material.
- Padded computer compartment.
- Padded shoulder straps.
- Two front multipurpose pockets.
- Dimensions: 45x30x15 cm.

- Material extra ligero.
- Compartimento acolchado para llevar el ordenador.
- Correas acolchadas para los hombros.
- Dos bolsillos delanteros multipropósito.
- Dimensiones: 45x30x15 cm.



COD. 92-27NR

## MATE REG



Bag for regulators.

- Material: 600D Polyester.
- Dimensions: diameter 32.5 cm, depth 10 cm.

Bolsa para el regulador.

- Material: Poliéster 600D.
- Dimensiones: diámetro 32.5 cm, profundidad 10 cm.

COD. 092-21

## SOFT DRY BAG



Soft watertight bag in various capacities.

Bolsa hermética suave de varias capacidades.

LITERS   LITROS	15 Lt.	10 Lt.	5 Lt.
COD.	92-26AZ/15	92-26V/10	92-26O/5

## DRY BAG

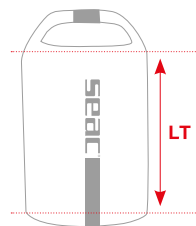

Dry bag with varying capacities and removable shoulder strap (1.5 Lt bag without shoulder strap).

Bolsa estanca con diversas capacidades y una correa extraíble (la bolsa de 1,5 l no incluye correa para el hombro).

LITERS   LITROS	20 Lt.	15 Lt.	10 Lt.	5 Lt.	2.5 Lt.	1.5 Lt.
COD.	92-18/20	92-18/15	92-18/10	92-18/5	92-18/2,5	92-18/1,5

## DRY CONTAINER | RECIPIENTE EN TUBO ESTANCO



Dry case, closes with 12 X Ø 4.5 cm screws.

Tubo estanco que se cierra con 12 tornillos de 4,5 cm de diámetro.

COD. 2064
-----------



## LARGE BUOY BOYA GRANDE

- Height: 66 cm.
- Circumference: 121 cm.
- Line: 25 m.
- Altura: 66 cm.
- Circunferencia: 121 cm.
- Forro: 25 m.



COD. 196/D

## MASTER FLAG BANDERA MASTER



A COD. 196/C

B COD. 95-3YR (ONLY FOR GREECE | SOLO PARA GRECIA)

## SMALL BUOY BOYA PEQUEÑA

- Height: 56 cm.
- Circumference: 102 cm.
- Line: 25 m.
- Altura: 56 cm.
- Circunferencia: 102 cm.
- Forro: 25 m.



COD. 195/B

## TORPEDO BUOY BOYA TORPEDO



Height: 23 cm. Height + Flag: 50 cm.  
Circumference: 170 cm. Line: 25 m.

Altura: 23 cm. Altura + Bandera: 50 cm.  
Circunferencia: 170 cm. Línea: 25 m.

COD. 188/B

## EMERGENCY BUOY BOYA DE EMERGENCIA



Vertical inflatable buoy including line and carabiner.  
Great for signaling a diver underwater or for a safety stop.

Boya inflable vertical que incluye una línea y mosquetón.  
Perfecta para indicar que hay un buceador bajo el agua o para realizar las paradas de seguridad.

COD. 953

## SPHERICAL FLUORESCENT BUOY BOYA FLUORESCENTE ESFÉRICA

- Height: 31 cm.
- Height + Flag: 57 cm.
- Circumference: 104 cm.
- Line: 25 m.

- Altura: 31 cm.
- Altura + bandera: 57 cm.
- Circunferencia: 104 cm.
- Forro: 25 m.



COD. 189/B

## DIVING BELT CINTURÓN DE BUCEO

MADE IN ITALY



Length 140 cm.

Longitud de 140 cm.

MATERIAL	INOX	NYLON
BLACK/BLUE	191NB	192NB
BLACK/SILVER	191NS	192NS

## BELT WITH POCKETS CINTURÓN CON BOLSILLOS



Number of compartments varies by size:  
S-3, M-4, L-5, XL-5.

El número de compartimentos variará en función de la talla:  
S-3, M-4, L-5 y XL-5.

SIZE   TALLA	S	M	L	XL
COD.	19402/S	19403/M	19404/L	19405/XL

## NYLON/INOX BUCKLE HEBILLA EN INOX Y NYLON

MADE IN ITALY



Universal buckles in stainless steel or nylon.

Hebillas universales en acero inoxidable y nailon.

MATERIAL	INOX	NYLON
COD.	191/B	192/B

## WEIGHTS PLOMOS DE LASTRE

MADE IN ITALY



WEIGHT   PESO	1 kg	2 kg
COD.	182	183

## SPOOL REEL



Dual stainless steel carabiner, with 30 meters of white Ø 2 mm line.

Doble mosquetón de acero inoxidable y 30 metros de cabo blanco de 2 mm de diámetro.

COD. 2068

## SPOOL REEL



Dual stainless steel carabiner, with 30 meters of yellow Ø 2 mm line.

Doble mosquetón de acero inoxidable y 30 metros de cabo amarillo de 2 mm de diámetro.

COD. 111-103Y

## SOFT ECO-FRIENDLY WEIGHTS PESOS SUAVES ECOLÓGICOS

MADE IN ITALY



Lead shot packaged in nylon/polyurethane sacks.  
Advanced resistance to saline corrosion.

Trozos de plomo embalados dentro de bolsitas de nailon/poliuretano.  
Resistencia avanzada contra la corrosión salina.

WEIGHT   PESO	1 kg	1.5 kg	2 kg
COD.	1811	1812	1813

## BARBELL WEIGHT PESO EN FORMA DE MANCUERNA

MADE IN ITALY



300 gr. barbell-shaped weight.

Lastre de 300 gramos de forma de mancuerna.

COD. 1865

## WEIGHT FASTENER UNIDAD FIJADORA DE PLOMOS



Universal nylon weight fasteners for belts.

Unidades universales de nailon para la fijación de los plomos  
en el cinturón.

COD. 2040N

4 PIECES | 4 UNIDADES

## COMPACT SLATE PIZARRA COMPACTA

Slate and pencil for  
communicating underwater.

Pizarra y lápiz para  
comunicarse bajo el agua.



COD. 111-100

## FLASH LIGHT



Flashing dive light for use at night or when visibility is poor.  
Burn time: 700 hours. Turns on when it hits the water.  
Max depth: 100 mt.

Linterna sumergible intermitente para usar por la noche o en  
condiciones de poca visibilidad. Autonomía: 700 horas.  
Se enciende al contacto con el agua. Profundidad máxima: 100 m.

COD. 2059

## TWO-TONE WHISTLE SILBATO DE DOS TONOS

Two-tone whistle in CE  
type approved plastic.

Silbato de dos tonos en tipo de  
plástico aprobado por el mercado CE.



COD. 80012



## Full-face masks | Máscaras enteras

Fun, comfortable, and technologically advanced: these are the exclusive full-face snorkeling masks from SEAC®. We have meticulously crafted even the smallest details to ensure comfort and truly natural breathing through your nose or mouth. The attractive design, the patented technical solutions applied, the different sizes offered, and our range of colors make SEAC® full-face masks truly one of a kind in their category.

Divertidas, cómodas y tecnológicamente avanzadas: éstas son las exclusivas máscaras completas de SEAC®. Hemos diseñado meticulosamente incluso los detalles más pequeños, para garantizar la comodidad y una respiración natural por la boca y la nariz. El diseño atractivo, las soluciones técnicas patentadas que se aplican, los diferentes tamaños ofrecidos, y nuestra variedad de colores, hacen que las máscaras completas de SEAC® sean verdaderamente únicas en cuanto a su categoría.





# SEAC®

sea is calling  
CO<sub>2</sub> TEST

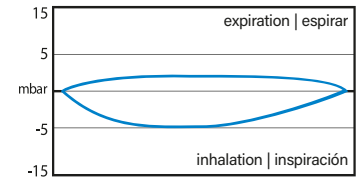

Natural breathing effort  
Esfuerzo respiratorio natural

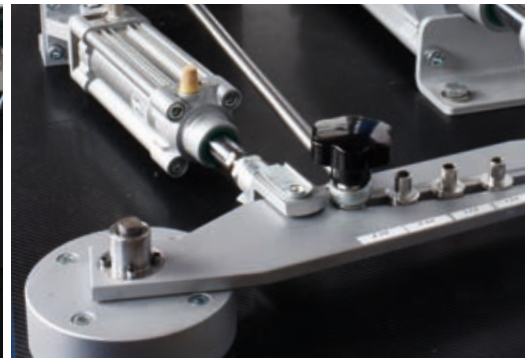
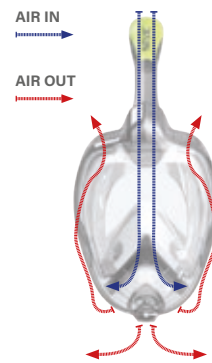

## SECURITY CONTROLS | CONTROLES DE SEGURIDAD

In the **SEAC® labs**, batches of full-face masks are tested with **Ansti machines**, specifically to measure the **dynamic performance of human breathing**, and with **proprietary SEAC® equipment** to **check levels of CO<sub>2</sub>** in the air inhaled through the masks.

- EN 1972:2015 establishes the requirements for the design and manufacture of snorkel tubes, limited to breathing effort;
- EN 16805:2015 establishes the requirements for the design and manufacture of dive masks;
- EN 136:2000 establishes the minimum requirements for the manufacture of full-face respiratory protection masks, limited to tests checking the CO<sub>2</sub> in inhaled air;
- EN 250:2014 regarding open-circuit compressed-air self-contained breathing apparatus and its components, limited to tests checking the CO<sub>2</sub> in inhaled air.

En los **laboratorios de SEAC®**, los lotes de máscaras completas son probados con **máquinas Ansti**, específicamente para medir el **desempeño dinámico de la respiración humana**, y con **equipo patentado de SEAC®** para **comprobar los niveles de CO<sub>2</sub>** en el aire inhalado a través de las máscaras.

SEAC® ha desarrollado una serie de **pruebas específicas** que cumplen con los valores establecidos por las siguientes regulaciones europeas:

- La regulación EN 1972:2015 establece los requisitos para el diseño y la fabricación de los tubos de esnórquel, limitada al esfuerzo respiratorio;
- La regulación EN 16805:2015 establece los requisitos para el diseño y la fabricación de máscaras de buceo;
- La regulación EN 136:2000 establece los requisitos mínimos para la fabricación de máscaras completas para protección de la respiración, limitada a pruebas para comprobar el CO<sub>2</sub> en el aire inhalado;
- La regulación EN 250:2014 con respecto a equipos respiratorios autónomos de aire comprimido y circuito abierto y sus componentes, limitada a pruebas para comprobar el CO<sub>2</sub> en el aire inhalado.



## LIBERA L/XL - S/M | LIBERA xs/s

The evolution of full-face masks for snorkeling. Natural breathing through your mouth and nose, with the lowest breathing effort in its category. Completely separate circuits for fresh air (IN) and exhaled air (OUT). Exhaled air is expelled through a SEAC® patented exhaust circuit. Anti-fogging system guaranteed by the continuous flow of incoming air. One-way valves with a larger cross section for effortless exhalation and effective expulsion of residual CO<sub>2</sub>. The smaller internal volume offers an even broader field of vision and an optimization of residual CO<sub>2</sub>. A large anatomical hypoallergenic liquid silicone skirt with a shape designed to adapt to every kind of facial contour ensures the very best seal, safety, and comfort. The snorkel features a Dry Top to prevent water from entering the tube. Effective water elimination system uses a purge valve at the bottom. Silicone strap with co-molded colored insert. Two ways to adjust the strap, both in front and in the lower section. Quick-release buckles to release the strap instantly. Available in sizes L/XL, S/M designed for narrower faces and XS/S for kids (+10).



La evolución de las máscaras completas para practicar esnórquel. Respiración natural a través de la nariz y la boca, con el menor esfuerzo respiratorio en su categoría. Circuitos totalmente separados para aire fresco (entrante) y aire exhalado (saliente). El aire exhalado se expulsa a través del circuito de purga patentado de SEAC®. El sistema antivaho está garantizado por el flujo continuo de aire entrante. Válvulas de una sola vía con una sección transversal más grande, para permitir una exhalación sin esfuerzo y una expulsión eficaz del CO<sub>2</sub> residual. El volumen interno es más pequeño y ofrece un campo de visión aún más amplio, y una optimización de CO<sub>2</sub> residual. Tiene un faldón grande y anatómico, hecho de silicona líquida hipoalérgica, capaz de adaptarse a cualquier tipo de contorno facial para garantizar el mejor sellado, seguridad y comodidad. El esnórquel incorpora el sistema Dry Top para evitar que entre agua en el tubo. El sistema eficaz de eliminación de agua usa una válvula de descarga en la parte inferior. Correa de silicona con inserciones de colores. Dos formas de ajustar la correa, en la parte delantera y en la parte inferior. Hebillas de soltado rápido para quitar la correa instantáneamente. Disponible en versión para adultos L/XL, S/M para los rostros más finos y XS/S para chicos (+10).



## UNICA L/XL - S/M | UNICA JUNIOR

Unica is the full-face snorkeling mask designed and manufactured by SEAC®. It allows you to explore the world below the water's surface, breathing naturally through your nose and mouth. Exhaled air is vented through an exclusive patented system located in the front of the mask to make exhaling effortless and eliminate the noise that purge valves make. A separated channeling system for inhaled and exhaled air prevents the lens from fogging. The snorkel features a Dry Top to prevent water from entering the tube. Full-spectrum view, with a 180° field of vision. The liquid silicone skirt and polycarbonate frame and lens offer enormous comfort. A comfortable and flexible retaining strap holds the full-face mask to your head. An efficient water purging system uses a dump valve in the lower part of the skirt. Available in the L/XL adult version and S/M designed for narrower faces (+10) and Unica Junior for children (+6).



Unica es la máscara integral diseñada y fabricada por Seac para la práctica de esnórquel. Le permite explorar el mundo debajo de la superficie del agua pudiendo seguir respirando de manera natural por la boca y la nariz. El aire exhalado se evacua a través de un sistema patentado exclusivo que se ha ubicado en la parte delantera de la máscara para facilitar un proceso de exhalación sin esfuerzo, al tiempo que elimina el ruido que produce la válvula de purga. Su sistema de canalización separado para el aire inhalado y exhalado evita que la lente se empañe. El esnórquel incorpora el sistema Dry Top para evitar que entre agua en el tubo. Vista de espectro completo con un campo de visión 180°. El faldón de silicona líquida y la montura y el lente hechos en policarbonato ofrecen un gran confort. Una tira de sujeción cómoda y flexible mantiene la máscara integral bien sujeta a la cabeza. Su eficaz sistema de purgado del agua se ayuda de una válvula de descarga que se ha ubicado en la parte más inferior del faldón. Disponible en versión para adultos L/XL, S/M para los rostros más finos y Unica Junior para los niños (+6).



## MAGICA L/XL - S/M | MAGICA FUN xs/s | MAGICA JUNIOR

Magica is the full-face snorkeling mask designed and manufactured by SEAC®. It allows you to explore the world below the water's surface, breathing naturally through your nose and mouth. Exhaled air is vented through an exclusive patented system located in the front of the mask to make exhaling effortless and eliminate the noise that purge valves make. A separate channeling system for inhaled and exhaled air prevents the lens from fogging. The snorkel features a Dry Top to prevent water from entering the tube. Full-spectrum view, with a 180° field of vision. Soft, ergonomic skirt made of thermoplastic elastomer paired with a durable polycarbonate frame. A comfortable and flexible retaining strap holds the full-face mask to your head. An efficient water purging system uses a dump valve in the lower part of the skirt. Available in the adult L/XL version, the S/M and Magica Fun XS/S for narrower faces (+10) and the Magica Junior for children (+6).



Magica es la máscara integral de esnórquel diseñada y fabricada por SEAC® que le permite descubrir el mundo submarino desde la superficie, respirando de forma natural a través de la nariz y la boca. Descarga del aire espirado con sistema exclusivo patentado en la zona delantera para eliminar todo el esfuerzo de espiración y evitar los ruidos generados por las válvulas de purga. Sistema de canalización separado para el aire inspirado y espirado que evita el empañamiento de la máscara. Tubo con extremo superior seco para impedir la entrada de agua. Pantalla panorámica, con campo visual de 180°. Faldón suave y ergonómico fabricado en elastómero termoplástico unido a una montura de resistente policarbonato. Cómoda correa de sujeción entre la máscara integral y la cabeza fabricada en tejido elástico. Eficaz sistema de purga del agua mediante válvula de descarga en la parte inferior del faldón. Disponible en versión para adultos L/XL, S/M y Magica Fun XS/S para los rostros más finos y Magica Junior para los niños (+6).



- L/XL  
+12.5 cm | +4.9 inch
- S/M  
+11.5 cm | +4.5 inch
- XS/S  
+10 cm | +3.9 inch
- JUNIOR  
-10 cm | -3.9 inch

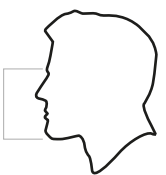



# LIBERA

ITALIAN DESIGN

snorkeling|2020



LIBERA L/XL



LIBERA S/M



LIBERA XS/S

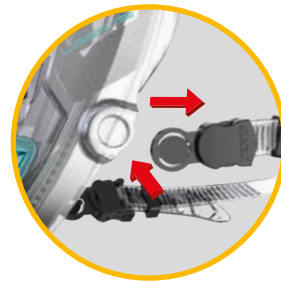

LIBERA L/XL - S/M



LIBERA XS/S

Quick release clips  
Zafado rápido

LIBERA L/XL			
MODEL   MODELO	S/KL	S/BL	
AQUAMARINE/ORANGE	170-5AO/SKL	-	
BLACK/ORANGE	170-5NO/SKL	-	
BLACK/LIME	-	170-5NL/SBL	

LIBERA S/M	
MODEL   MODELO	S/KL
TRANSPARENT/PINK	170-6TP/SKL
AQUAMARINE/ORANGE	170-6AO/SKL
BLACK/ORANGE	170-6NO/SKL

LIBERA XS/S	
MODEL   MODELO	S/KL
TRANSPARENT/PINK	170-7TP/SKL
AQUAMARINE/ORANGE	170-7AO/SKL
BLACK/ORANGE	170-7NO/SKL



# UNICA

ITALIAN DESIGN



UNICA L/XL



UNICA S/M



UNICA JUNIOR



275X415 MM

### UNICA L/XL

MODEL   MODELO	S/KL	S/BL
BLUE/ORANGE	170-1BO/SKL	-
BLACK/ORANGE	170-1NO/SKL	-
RED/BLACK	170-1RN/SKL	-
BLACK/LIME	-	170-1NL/SBL

### UNICA S/M

MODEL   MODELO	S/KL	S/BL
WHITE/PINK	170-2WP/SKL	-
BLUE/ORANGE	170-2BO/SKL	-
BLACK/LIME	170-2NL/SKL	-
BLACK/ORANGE	-	170-2NO/SBL

### UNICA JUNIOR

MODEL   MODELO	S/KL	S/BL
WHITE/PINK	170-13WP/SKL	-
BLUE/ORANGE	170-13BO/SKL	-
BLACK/LIME	-	170-13NL/SBL



# MAGICA

ITALIAN DESIGN



MAGICA L/XL



MAGICA S/M



snorkeling|2020



MAGICA FUN XS/S



MAGICA JUNIOR



MAGICA L/XL			
MODEL   MODELO	SLT	SLT/FU	
WHITE/BLUE	170-9WO/SLT	-	
BLUE/ORANGE	-	170-9BO/SLT	
BLACK/LIME	-	170-9FL/SLT	

MAGICA S/M			
MODEL   MODELO	SLT	SLT/FU	
WHITE/PINK	170-10WP/SLT	-	
WHITE/BLUE	170-10WO/SLT	-	
BLUE/ORANGE	-	170-10BO/SLT	

MAGICA FUN XS/S			
MODEL   MODELO	SLT	SLT/FU	
WHITE/PINK	170-14WP/SLT	-	
WHITE/BLUE	170-14WO/SLT	-	
BLUE/ORANGE	-	170-14BO/SLT	

MAGICA JUNIOR		
MODEL   MODELO	SLT	
AQUAMARINE	170-12AO/SLT	
PINK	170-12PT/SLT	
LIME	170-12LT/SLT	





## SET UNICA



Set includes Sprint fins and Unica full-face mask.

Conjunto compuesto por aletas Sprint y por una máscara integral única.

SET UNICA S/M + SPRINT XS/S  
COD. 89-75B/XS-S

SET UNICA S/M + SPRINT S/M  
COD. 89-75B/S-M

SET UNICA L/XL + SPRINT M/L  
COD. 89-74B/M-L

SET UNICA L/XL + SPRINT L/XL  
COD. 89-74B/L-XL

## STRAP | TIRA

- LIBERA
- MAGICA FUN



COLOR	COD.
BLACK/GREEN	172-4NV/SBL
CLEAR/ORANGE	172-4T/SKL

## STRAP | TIRA

- UNICA
- UNICA JUNIOR
- MAGICA
- MAGICA FUN
- MAGICA JUNIOR



COLOR	COD.
LIME	172-3V
ORANGE	172-3O
PINK	172-3P

## ACTION CAM SUPPORT MONTAJE PARA CÁMARA DE ACCIÓN



COD. 172-2

## SNORKEL



COD. 172-1T





# Masks and snorkels | Máscaras y esnórqueles

Our products and their design feature exclusive technological innovation and consistent reliability: these are the founding principles that drive the work of our mask and mouthpiece designers every day at SEAC®. This enables us to offer a wide range of masks and mouthpieces structured to meet any diving need, ranging from a good fit against your face to your comfort and safety.

Nuestros productos y su diseño ofrecen una innovación tecnológica exclusiva y una confiabilidad constante: estos son los principios fundamentales que guían el trabajo que hacen día a día los diseñadores de máscaras y boquillas de SEAC®. Todo esto nos permite ofrecer una amplia gama de máscaras y boquillas pensadas para satisfacer cualquier necesidad en el buceo, empezando por un buen ajuste del rostro que favorezca una mayor comodidad y seguridad.





# ONE

ITALIAN DESIGN



S/KL ONE



S/KL ONE BOX 20 PCS



S/KL ONE



OPTIONAL OPTICAL LENSES  
-1.0 to -6.0



TEMPERED GLASS



PURE SILICONE

S/KL ONE BOX 20 PCS

- Frame: polycarbonate.
- Skirt: high-quality hypoallergenic liquid silicone.
- Strap: silicone.
- Lenses: in tempered glass.
- Optical lenses: options from -1.0 to -6.0.
- Buckle on the frame with Easy Touch system.
- Option to mount optical lenses.

- Montura: policarbonato.
- Faldón: silicona líquida hipoalergénica.
- Tira: silicona.
- Lentes: en cristal templado.
- Lente óptica: opciones de -1,0 a -6,0.
- Hebilla en la montura con el sistema Easy Touch.
- Opción para cambiar a lente óptica.



Package of 6 per code in all color options.  
Option for 20-piece pack for ONE S/KL GREY (COD. DE9448N) in soft box.

Paquete de 6 unidades por código en todas las opciones de colores.  
Opción de paquete de 20 piezas para ONE S/KL GREY (COD. DE9448N) en una caja blanda.

MODEL   MODELO	ONE S/KL	ONE BOX 20 PCS S/KL
BLUE	9448B	-
CLEAR BLUE	9448BC	-
YELLOW	9448Y	-
BLACK	9448N	DE9448N



# ONE PRO



- Frame: polycarbonate.
- Skirt: high-quality hypoallergenic liquid silicone.
- Strap: silicone.
- Lenses: in tempered glass.
- Optical lenses: options from -1.0 to -6.0.
- Packaging: transparent rigid box included.
- Action Cam mount.
- Buckle on the frame with Easy Touch system.
- Option to mount optical lenses.

- Montura: policarbonato.
- Faldón: silicona líquida hipoalergénica.
- Tira: silicona.
- Lentes: en cristal templado.
- Lente óptica: opciones de -1,0 a -6,0.
- Embalaje: incluye una caja rígida transparente.
- montaje para cámara de acción.
- Hebilla en la montura con el sistema Easy Touch.
- Opción para cambiar a lente óptica.

MODEL   MODELO	S/KL	S/BL
<span style="color: blue;">■</span> CLEAR BLUE	75-56BC/SKL	-
<span style="color: black;">■</span> BLACK	75-56N/SKL	75-56N/SBL



6 pieces/unit  
6 unidades/código



# EXTREME

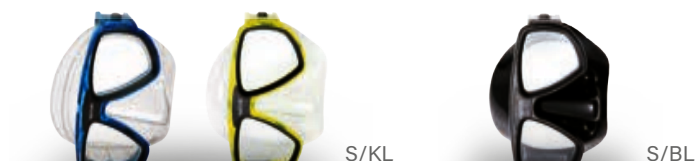

- Frame: polycarbonate.
- Skirt: hypoallergenic liquid silicone.
- Strap: silicone.
- Lenses: in tempered glass.
- Optical lenses: options from -1.0 to -6.0.
- Other features: buckle on the skirt featuring the Tubing Connected System that ensures a secure seal and minimizes the pressure of the mask against your face. Anatomical skirt in high-quality liquid silicone. Option to mount optical lenses.

- Montura: policarbonato.
- Faldón: silicona líquida hipoalergénica.
- Tira: silicona.
- Lentes: en cristal templado.
- Lente óptica: opciones de -1,0 a -6,0.
- Otras prestaciones: faldón anatómico en silicona líquida de gran calidad. Hebilla en la montura con el sistema Easy Touch. Opción para cambiar a lente óptica.

MODEL   MODELO	S/KL	S/BL
<span style="color: blue;">■</span> CLEAR BLUE	75-33BC/SKL	-
<span style="color: yellow;">■</span> YELLOW	75-33Y/SKL	-
<span style="color: black;">■</span> BLACK	-	75-33N/SBL



6 pieces/unit  
6 unidades/código



# ELBA

ITALIAN DESIGN

S/KL



S/BL



6 pieces/unit  
6 unidades/código

Tempered glass dual-lens mask with silicone skirt.  
 • Polycarbonate frame.  
 • Buckle on the frame makes adjusting a breeze.

Máscara de dos lentes con vidrio templado y un faldón hecho en silicona hipoalergénica de alta calidad.  
 • Montura hecha de policarbonato.  
 • La hebilla que lleva en la montura hace que su ajuste sea aún más fácil.



ELBA		
MODEL   MODELO	S/KL	S/BL
AQUAMARINE	75-41A/SKL	-
WHITE	75-41W/SKL	-
BLUE	75-41B/SKL	-
YELLOW	75-41Y/SKL	-
BLACK	-	75-41N/SBL
BLACK/WHITE	-	75-41NW/SBL



# ELBA MD

ITALIAN DESIGN

S/KL



S/BL



6 pieces/unit  
6 unidades/código

- Tempered glass dual-lens mask with silicone skirt.
- Suitable for children and people with a slender face.
  - Buckle on the frame makes adjusting a breeze.

- Máscara de dos lentes con vidrio templado y un faldón hecho en silicona hipoalergénica de alta calidad.
- resulta muy práctica para niños o personas con una forma facial más delgada.
  - La hebilla que lleva en la montura hace que su ajuste sea aún más fácil.

ELBA MD			
MODEL   MODELO	S/KL	S/BL	
<input type="checkbox"/> WHITE	75-42W/SKL	-	
<input type="checkbox"/> BLUE	75-42B/SKL	-	
<input type="checkbox"/> YELLOW	75-42Y/SKL	-	
<input type="checkbox"/> PINK	75-42P/SKL	-	
<input type="checkbox"/> BLACK	-	75-42N/SBL	
<input type="checkbox"/> BLACK/WHITE	-	75-42NW/SBL	



# GIGLIO

ITALIAN DESIGN

S/KL



S/BL



6 pieces/unit  
6 unidades/código

Tempered glass single-lens mask with high-quality hypoallergenic silicone skirt.

- Polycarbonate frame.
- Buckle on the frame makes adjusting a breeze.

Máscara de un lente y vidrio templado, disponible con un faldón de silicona hipoalergénica.

- Montura hecha de policarbonato.
- Hebilla con doble botón en la montura para un ajuste incluso más fácil.

GIGLIO		
MODEL   MODELO	S/KL	S/BL
AQUAMARINE	75-47A/SKL	-
WHITE	75-47W/SKL	-
BLUE	75-47B/SKL	-
YELLOW	75-47Y/SKL	-
BLACK	-	75-47N/SBL
BLACK/WHITE	-	75-47NW/SBL

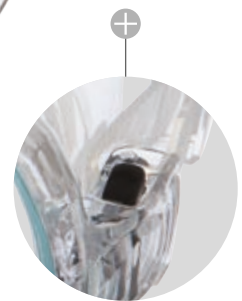

# GIGLIO MD

ITALIAN DESIGN

S/KL



S/BL



6 pieces/unit  
6 unidades/código

Tempered glass single-lens mask with high-quality hypoallergenic silicone skirt.

- Suitable for children and people with a slender face.
- Buckle on the frame makes adjusting a breeze.

Máscara de un solo lente con vidrio templado y un faldón hecho en silicona hipoalérgica de alta calidad.

- resulta muy práctica para niños o personas con una forma facial más delgada.

GIGLIO MD			
MODEL   MODELO	S/KL	S/BL	
<input type="checkbox"/> WHITE	75-48W/SKL	-	
<input type="checkbox"/> BLUE	75-48B/SKL	-	
<input type="checkbox"/> YELLOW	75-48Y/SKL	-	
<input type="checkbox"/> PINK	75-48P/SKL	-	
<input type="checkbox"/> BLACK	-	75-48N/SBL	
<input type="checkbox"/> BLACK/WHITE	-	75-48NW/SBL	





## BELLA - BELLA COLOR

ITALIAN DESIGN

S/KL



S/COL



6 pieces/unit  
6 unidades/código

Dual-lens mask with tempered glass and a hypoallergenic silicone skirt. Suitable for children and adults with more slender faces.

Máscara de un lente con vidrio templado y un faldón hecho en silicona hipoalergénica. Apta para niños.

BELLA		S/KL
MODEL   MODELO		
AQUAMARINE		75-45A/SKL
YELLOW		75-45Y/SKL

BELLA COLOR		S/COL
MODEL   MODELO		
CLEAR BLUE		75-45AZ/SAZ
PINK		75-45P/SPI

## MARINA - MARINA COLOR

ITALIAN DESIGN

S/KL



S/COL



6 pieces/unit  
6 unidades/código

Single-lens mask in tempered glass with a hypoallergenic silicone skirt. Suitable for children.

Máscara de un lente con vidrio templado y un faldón hecho en silicona hipoalergénica de color. Apta para niños.

MARINA		S/KL
MODEL   MODELO		
BLUE		9426B
YELLOW		9426Y
PINK		9426P

MARINA COLOR		S/COL
MODEL   MODELO		
CLEAR BLUE		75-7AZ/SAZ
PINK		75-7P/SPI

## BAIA

ITALIAN DESIGN



SEBS



6 pieces/unit  
6 unidades/código

Frameless single-lens mask with a special hypoallergenic elastomer skirt. Shock-resistant polycarbonate safety lens. Easy Touch Buckle, with quick-adjust button on the strap. Liquid silicone strap. Ideal for snorkeling. Suitable for children from 4 to 8 years old.

Máscara sin montura de un solo lente con un faldón especial hecho en elastómero hipoalergénico. Lentes de seguridad hechas en policarbonato resistente a los golpes. Hebilla Easy Touch con botón de ajuste rápido en la tira. Tira hecha de silicona líquida. Ideal para esnórquel. Apta para niños de edades comprendidas entre 4 y 8 años.

MODEL   MODELO	SEBS
 AQUAMARINE	75-38A/TPRAQ
 PINK	75-38P/TPRPI

## BAIA KID

ITALIAN DESIGN



SEBS



6 pieces/unit  
6 unidades/código

Frameless single-lens mask with a special hypoallergenic elastomer skirt. Shock-resistant polycarbonate safety lens. Easy Touch Buckle, with quick-adjust button on the strap. Liquid silicone strap. Ideal for snorkeling. Suitable for children from 3 to 6 years old.

Máscara sin montura de un solo lente con un faldón especial hecho en elastómero hipoalergénico. Lentes de seguridad hechas en policarbonato resistente a los golpes. Hebilla Easy Touch con botón de ajuste rápido en la tira. Tira hecha de silicona líquida. Ideal para esnórquel. Apta para niños de edades comprendidas entre 3 y 6 años.

MODEL   MODELO	SEBS
 AQUAMARINE	75-39A/TPRAQ
 PINK	75-39P/TPRPI

## ISCHIA

ITALIAN DESIGN

SLT



6 pieces/unit  
6 unidades/código

Dual-lens mask with tempered glass and hypoallergenic SLT skirt that guarantees it will sit comfortably against your face.

Máscara de dos lentes con vidrio templado y faldón en SLT hipoalergénica, que garantiza una comodidad excelente al llevarla puesta.

ISCHIA	
MODEL   MODELO	SLT
■ BLUE	75-43B
■ YELLOW	75-43Y

## ISCHIA MD

ITALIAN DESIGN

SLT



6 pieces/unit  
6 unidades/código

Dual-lens mask with tempered glass and hypoallergenic SLT skirt that guarantees it will sit comfortably against your face.

Máscara de dos lentes con vidrio templado y faldón en SLT hipoalergénica, que garantiza una comodidad excelente al llevarla puesta.

ISCHIA MD	
MODEL   MODELO	SLT
■ BLUE	75-44B
■ YELLOW	75-44Y



## PANAREA

ITALIAN DESIGN

SLT



6 pieces/unit  
6 unidades/código

Single-lens mask with tempered glass, hypoallergenic SLT skirt, and polycarbonate frame.

Máscara de un lente con vidrio templado, faldón en SLT hipoalergénica de color y montura de policarbonato.

PANAREA		
MODEL   MODELO	SLT	
■ BLUE	75-49B	
■ YELLOW	75-49Y	

## PANAREA MD

ITALIAN DESIGN

SLT



6 pieces/unit  
6 unidades/código

Single-lens mask with tempered glass and hypoallergenic SLT skirt that guarantees it will sit comfortably against your face.

Máscara de dos lentes con vidrio templado y faldón SLT hipoalergénica de color, que garantiza una excelente comodidad al llevarla puesta.

PANAREA MD		
MODEL   MODELO	SLT	
■ BLUE	75-50B	
■ YELLOW	75-50Y	

# MARINA SLT

ITALIAN DESIGN



6 pieces/unit  
6 unidades/código

Single-lens mask with phthalate-free SLT skirt.  
Suitable for children.

Máscara de un solo lente con faldón de SLT sin ftalatos.  
Apta para niños.

MODEL   MODELO	SLT
BLUE	9428B
YELLOW	9428Y
PINK	9428P



SLT

# PROCIDA - PROCIDA COLOR

ITALIAN DESIGN



6 pieces/unit  
6 unidades/código

Mask for kids with hypoallergenic SLT skirt.  
Dual-lens model with tempered glass.

Máscara para niños con faldón de SLT hipoalergénica transparente.  
Modelo de doble lente con vidrio templado.

PROCIDA		
MODEL   MODELO	SLT/COL	SLT
BLUE	75-46AZ/SLTAZ	75-46B
YELLOW	-	75-46Y
PINK	75-46P/SLTPI	75-46P



SLT/COL



SLT

# VORTEX DRY

ITALIAN DESIGN

S/BL

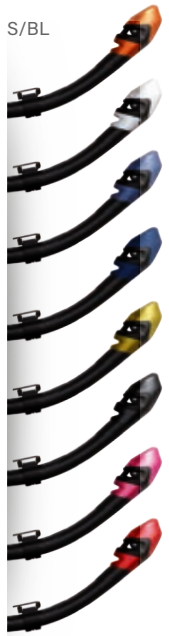

S/KL



## QUICK SNORKEL RETAINER RETENEDOR RAPIDO DE SNORKEL



COD. 0870009

Universal, for all snorkel types

Universal, para todos los tipos de tubos de esnórquel



PURE SILICONE



12 pieces/unit  
12 unidades/código

- Model: black or clear silicone snorkel with dry top system and purge valve.
- Mouthpiece: in liquid silicone.
- Tube: plastic material.
- Corrugated: in liquid silicone.

- Modelo: esnórquel de silicona negro o transparente con sistema Top Dry y válvula de descarga.
- Boquilla: silicona líquida.
- Tubo: material plástico.
- Parte corrugada: silicona líquida.

MODEL   MODELO	S/BL	MODEL   MODELO	S/KL
BLACK/ORANGE	84-22OM/SBL	AQUAMARINE	84-22A/SKL
BLACK/WHITE	84-22W/SBL	WHITE	84-22W/SKL
BLACK/CLEAR BLUE	84-22BC/SBL	WHITE/AQUAMARINE	84-22WA/SKL
BLACK/METALLIC BLUE	84-22BM/SBL	WHITE/PINK	84-22WP/SKL
BLACK/YELLOW	84-22Y/SBL	BLUE	84-22B/SKL
BLACK	84-22N/SBL	YELLOW	84-22Y/SKL
BLACK/PINK	84-22P/SBL	PINK	84-22P/SKL
BLACK/METALLIC RED	84-22RM/SBL		





# FAST TECH DRY

ITALIAN DESIGN



12 pieces/unit  
12 unidades/código

- Model: clear or black silicone snorkel with dry top system and purge valve.
- Mouthpiece: liquid silicone.
- Tube: plastic material.
- Other features: ABS body with liquid silicone corrugated hose; purge valve.

- Modelo: esnórquel de silicona negra o transparente con el sistema Dry Top y válvula de descarga.
- Boquilla: silicona líquida.
- Tubo: material plástico con manguera de silicona líquida corrugada.
- Otras prestaciones: manguera de silicona líquida corrugada, negra o transparente. Válvula de descarga. Válvula seca.

MODEL   MODELO	S/KL	S/BL
AQUAMARINE	84-32A/SKL	-
WHITE	84-32W/SKL	-
BLUE	84-32B/SKL	-
YELLOW	84-32Y/SKL	-
PINK	84-32P/SKL	-
BLACK	-	84-32N/SBL
BLACK/WHITE	-	84-32NW/SBL



# VORTEX

ITALIAN DESIGN



- Model: Snorkel with anti-splash top and purge valve.
- Mouthpiece: liquid silicone.
- Tube: body in plastic technopolymer with corrugated in liquid silicone and polycarbonate ends.
- Other features: purge valve. Anti-splash top.

- Modelo: tubo de esnórquel con sistema antisalpicaduras en la parte superior y válvula de descarga.
- Boquilla: silicona líquida.
- Tubo: cuerpo en tecnopolímero plástico con manguera en silicona líquida y extremos de policarbonato.
- Otras prestaciones: válvula de descarga. Parte superior antisalpicaduras.

MODEL   MODELO	S/KL	S/BL
<input type="checkbox"/> WHITE	84-1W/SKL	-
<input type="checkbox"/> BLUE	84-1B/SKL	-
<input type="checkbox"/> CLEAR BLUE	84-1BC/SKL	-
<input type="checkbox"/> TRANSPARENT	84-16T/SKL	-
<input checked="" type="checkbox"/> BLACK/RED	-	84-16NR/SBL

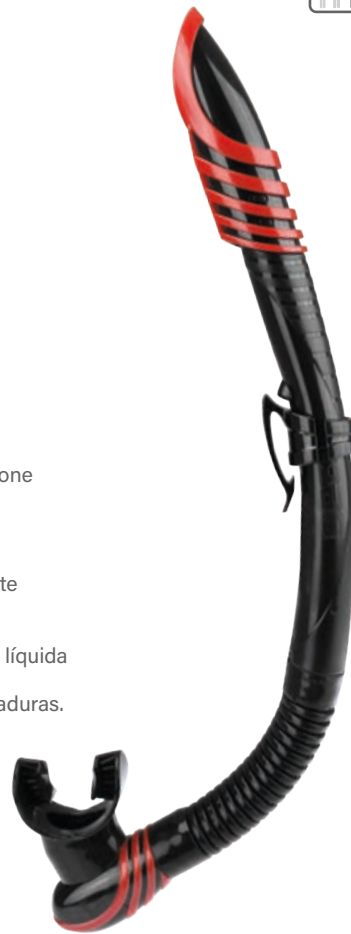

12 pieces/unit  
12 unidades/código



# FAST TECH

ITALIAN DESIGN



FAST SNORKEL RETAINER  
RETENEDOR DE SNORKEL FAST  
COD. 214N

- Model: Snorkel with anti-splash top and purge valve.
- Mouthpiece: silicone.
- Tube: ABS body with liquid silicone corrugated hose.

- Modelo: tubo de esnórquel con sistema antisalpicaduras en la parte superior y válvula de descarga.
- Boquilla: silicona.
- Tubo: cuerpo ABS con tubo corrugado de silicona líquida.

MODEL   MODELO	S/KL
<input checked="" type="checkbox"/> BLUE	476B
<input checked="" type="checkbox"/> YELLOW	476G
<input checked="" type="checkbox"/> BLACK	476N
<input checked="" type="checkbox"/> RED	476R



12 pieces/unit  
12 unidades/código



## FAST

ITALIAN DESIGN



12 pieces/unit  
12 unidades/código

Snorkel with anti-splash System. Mouthpiece in liquid silicone. The reduced internal volume in the tube decreases the quantity of exhaled air rich in carbon dioxide.

Tubo de esnórquel con sistema antisalpicaduras. Boquilla de silicona líquida. El volumen interno reducido en el tubo disminuye la cantidad de aire exhalado, rico en dióxido de carbono.

MODEL   MODELO	S/KL	S/BL
YELLOW	84-35Y/SKL	-
BLUE	84-35B/SKL	-
WHITE	84-35W/SKL	-
BLACK	84-35N/SKL	84-35N/SBL
AQUAMARINE	84-35A/SKL	-
PINK	84-35P/SKL	-



## JET

ITALIAN DESIGN



12 pieces/unit  
12 unidades/código

- Mouthpiece: silicone.
- Tube: plastic technopolymer.

- Esnórquel: Tecnopolímero plástico
- Boquilla: Silicona ergonómica.

MODEL   MODELO	S/KL
BLUE	483B
BLACK	483N
TRANSPARENT	483T



## FLASH

ITALIAN DESIGN



12 pieces/unit  
12 unidades/código

Plastic technopolymer snorkel with polycarbonate anti-splash top and silicone mouthpiece.

Tubo de esnórquel en tecnopolímero de plástico con sistema antisalpicaduras en la parte superior de policarbonato y boquilla de silicona.

MODEL   MODELO	S/KL	S/BL
AQUAMARINE	84-26A/SKL	-
WHITE	84-26W/SKL	-
BLUE	84-26B/SKL	-
YELLOW	84-26Y/SKL	-
BLACK	84-26N/SKL	84-26N/SBL
PINK	84-26P/SKL	-











# TRIBE DRY

ITALIAN DESIGN

Snorkel with dry top system and purge valve. Body in technopolymer and polycarbonate, mouthpiece in liquid silicone. The reduced inner volume of the tube lowers the amount of carbon-dioxide-rich exhaled air, making it especially well suited to kids and people of smaller stature.

Tubo de esnórquel con sistema Top Dry y válvula de fuga. Cuerpo hecho de tecnopolímero y policarbonato, y boquilla de silicona líquida. El reducido volumen interno del tubo disminuye la cantidad de aire espirada, rico en dióxido de carbono, lo que hace que sea especialmente adecuado para niños y personas de compleción pequeña.

MODEL   MODELO	S/KL
 AQUAMARINE	84-33A/SKL
 WHITE	84-33W/SKL
 BLUE	84-33B/SKL
 YELLOW	84-33Y/SKL
 BLACK	84-33N/SKL
 PINK	84-33P/SKL
 CLEAR BLUE	84-33AZ/SKL



NEW COLOR



PURE SILICONE



12 pieces/unit  
12 unidades/código



NEW COLOR

S/KL

# TRIBE

ITALIAN DESIGN

Snorkel with anti-splash top and purge valve. Body in technopolymer and polycarbonate, mouthpiece in liquid silicone. The reduced inner volume of the tube lowers the amount of carbon-dioxide-rich exhaled air, making it especially well suited to kids and people of smaller stature.

Tubo de esnórquel con sistema antisalpicaduras en la parte superior y válvula de descarga. Cuerpo hecho en tecnopolímero y policarbonato, y boquilla de silicona líquida. El volumen interior reducido del tubo reduce la cantidad de aire exhalado rico en dióxido de carbono, lo cual lo hace especialmente adecuado para niños y personas de poca estatura.

MODEL   MODELO	S/KL
 AQUAMARINE	84-27A/SKL
 WHITE	84-27W/SKL
 BLUE	84-27B/SKL
 YELLOW	84-27Y/SKL
 BLACK	84-27N/SKL
 PINK	84-27P/SKL



PURE SILICONE



12 pieces/unit  
12 unidades/código



S/KL

## Z GRANDE

ITALIAN DESIGN



Polythene snorkel with SLT mouthpiece.

Tubo de esnórquel hecho de polietileno con boquilla de SLT.

MODEL   MODELO	SLT
CLEAR BLUE	234BC
YELLOW	234G
BLACK	234N
TRANSPARENT	234T



12 pieces/unit  
12 unidades/código



## CLASSIC

MADE IN ITALY

Polythene snorkel with EPDM rubber mouthpiece.

Tubo de esnórquel de polietileno y boquilla de goma EPDM.

MODEL   MODELO	SLT
BLACK	211



12 pieces/unit  
12 unidades/código



## CORRUGATO

MADE IN ITALY

Polythene snorkel with flexible corrugated hose. EPDM rubber mouthpiece.

Tubo de esnórquel hecho de polietileno y manguito flexible corrugado. Boquilla de goma EPDM.

MODEL   MODELO	SLT
BLACK	230N



12 pieces/unit  
12 unidades/código



## Z PICCOLO

ITALIAN DESIGN

Snorkel for children in polythene with SLT mouthpiece.

Tubo de esnórquel hecho de polietileno y boquilla de SLT.

MODEL   MODELO	SLT
CLEAR BLUE	233BC
YELLOW	233G
PINK	233F
TRANSPARENT	233T



12 pieces/unit  
12 unidades/código



### QUICK SNORKEL RETAINER RETENEDOR RAPIDO DE SNORKEL



Universal, for all snorkel types.  
Universal, para todos los tipos de tubos de esnórquel.

COD. 0870009

### UNIVERSAL SNORKEL RETAINER RETENEDOR UNIVERSAL DE SNORKEL



Universal Ø 26 ring loop.  
Anilla universal de 26 mm de diámetro.

COD. 211/D

### FAST RETAINER RETENEDOR DE SNORKEL FAST



Black Fast snorkel retainer.  
Retenedor de snorkel Fast negro.

COD. 214N

### SNORKEL RETAINER RING ANILLA DE SUJECIÓN PARA ESNÓRQUEL



Universal snorkel retainer loop.  
Anilla de sujeción universal para tubo de esnórquel.

COD. S43005

## Pinne | Fins

Quick, agile, fluid kicks for products that offer the maximum comfort and are incredibly easy to use: SEAC® snorkeling fins are ideal for getting the most fun out of every second you spend in the water.

Aleteadas rápidas, ágiles y fluidas para productos que ofrecen la máxima comodidad y que presentan una facilidad de uso inimaginable: Las aletas para esnórquel de SEAC® son perfectas para aprovechar al máximo cada minuto que pasamos en el agua.





## SPEED

MADE IN ITALY

Full-foot fin with blade made in 3 materials, and foot pocket in soft thermoplastic rubber. It features optimized geometries to deliver the most power from your efforts. Offered in 10 sizes.

Aleta de calzante cerrado con una pala elaborada en 3 materiales y cavidad para el pie hecha en suave caucho termoplástico. Integra unas formas geométricas optimizadas con el fin de conferir una potencia máxima en cada aleteo. Disponible en 10 tallas.



SIZE   TALLA	26/28	29/31	32/33	34/35	36/37
WHITE	71-15W/26-28	71-15W/29-31	71-15W/32-33	71-15W/34-35	71-15W/36-37
BLUE	71-15B/26-28	71-15B/29-31	71-15B/32-33	71-15B/34-35	71-15B/36-37
YELLOW	71-15Y/26-28	71-15Y/29-31	71-15Y/32-33	71-15Y/34-35	71-15Y/36-37
BLACK	71-15N/26-28	71-15N/29-31	71-15N/32-33	71-15N/34-35	71-15N/36-37
CLEAR BLUE	71-15BAZ/26-28	71-15WAZ/29-31	71-15WAZ/32-33	71-15WAZ/34-35	71-15WAZ/36-37

SIZE   TALLA	38/39	40/41	42/43	44/45	46/47
WHITE	71-15W/38-39	71-15W/40-41	71-15W/42-43	71-15W/44-45	71-15W/46-47
BLUE	71-15B/38-39	71-15B/40-41	71-15B/42-43	71-15B/44-45	71-15B/46-47
YELLOW	71-15Y/38-39	71-15Y/40-41	71-15Y/42-43	71-15Y/44-45	71-15Y/46-47
BLACK	71-15N/38-39	71-15N/40-41	71-15N/42-43	71-15N/44-45	71-15N/46-47
CLEAR BLUE	71-15WAZ/38-39	71-15WAZ/40-41	71-15WAZ/42-43	71-15WAZ/44-45	71-15WAZ/46-47



6 pieces/unit  
6 unidades/código

## TEAM

MADE IN ITALY

Small blade, full-foot fin, made in 3 materials. Excellent for snorkeling, and ideal for leg workouts in the pool.

Aleta de calzante cerrado y una pala más pequeña que la media, elaborada en 3 materiales. Perfecta para practicar esnórquel e ideal para entrenar las piernas en la piscina.

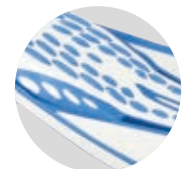

6 pieces/unit  
6 unidades/código

SIZE   TALLA	34/35	36/37	38/39	40/41	42/43	44/45	46/47
BLUE	71-28B/34-35	71-28B/36-37	71-28B/38-39	71-28B/40-41	71-28B/42-43	71-28B/44-45	71-28B/46-47
BLACK	71-28N/34-35	71-28N/36-37	71-28N/38-39	71-28N/40-41	71-28N/42-43	71-28N/44-45	71-28N/46-47
RED	71-28R/34-35	71-28R/36-37	71-28R/38-39	71-28R/40-41	71-28R/42-43	71-28R/44-45	71-28R/46-47
GREEN	71-28V/34-35	71-28V/36-37	71-28V/38-39	71-28V/40-41	71-28V/42-43	71-28V/44-45	71-28V/46-47

# ALA

ITALIAN DESIGN

Full-foot fin that's great for snorkeling. Comfortable foot pocket in soft thermoplastic rubber. Dual-material blade designed and manufactured to achieve good propulsion with minimal effort, ensuring excellent performance. Offered in 9 sizes.

Aleta de calzante cerrado perfecta para la práctica de esnórquel. Cómoda cavidad para el pie elaborada en suave caucho termoplástico. Pala elaborada en dos materiales y diseñada y fabricada para obtener una buena propulsión con un mínimo esfuerzo, asegurando un rendimiento excelente. Disponible en 9 tallas.



SIZE   TALLA	28/30	31/33	34/35	36/37
WHITE	71-33W/28-30	71-33W/31-33	71-33W/34-35	71-33W/36-37
METALLIC BLUE	71-33BM/28-30	71-33BM/31-33	71-33BM/34-35	71-33BM/36-37
YELLOW	71-33Y/28-30	71-33Y/31-33	71-33Y/34-35	71-33Y/36-37
PINK	71-33P/28-30	71-33P/31-33	71-33P/34-35	71-33P/36-37

SIZE   TALLA	38/39	40/41	42/43	44/45	46/47
WHITE	71-33W/38-39	71-33W/40-41	71-33W/42-43	71-33W/44-45	71-33W/46-47
METALLIC BLUE	71-33BM/38-39	71-33BM/40-41	71-33BM/42-43	71-33BM/44-45	71-33BM/46-47
YELLOW	71-33Y/38-39	71-33Y/40-41	71-33Y/42-43	71-33Y/44-45	71-33Y/46-47
PINK	71-33P/38-39	-	-	-	-



6 pieces/unit  
6 unidades/código

# SPINTA

ITALIAN DESIGN

Full-foot fin that's great for water sports. Geometries and materials optimized to deliver excellent power, but also to satisfy the primary goal of delivering the easiest and most comfortable finning action. Offered in 9 sizes.

Aleta de calzante cerrado perfecta para la práctica de deportes acuáticos. Integra unas geometrías y materiales optimizados no sólo para ofrecer una potencia excelente sino también para satisfacer el objetivo principal de ofrecer unos ciclos de aleteo más fáciles y cómodos. Disponible en 9 tallas.



SIZE   TALLA	28/30	31/33	34/35	36/37
BLUE	71-39B/28-30	71-39B/31-33	71-39B/34-35	71-39B/36-37
YELLOW	71-39Y/28-30	71-39Y/31-33	71-39Y/34-35	71-39Y/36-37

SIZE   TALLA	38/39	40/41	42/43	44/45	46/47
BLUE	71-39B/38-39	71-39B/40-41	71-39B/42-43	71-39B/44-45	71-39B/46-47
YELLOW	71-39Y/38-39	71-39Y/40-41	71-39Y/42-43	71-39Y/44-45	71-39Y/46-47



6 pieces/unit  
6 unidades/código

# SPRINT

ITALIAN DESIGN

Open-heel fin adjustable to 6 different positions per size. Closure system using highly elastic and durable elastomer strap. Blade made of a special polyolefin resin and foot pocket in thermoplastic rubber.

Aleta de calzante abierto ajustable en 6 posiciones diferentes por talla. Sistema de cierre que se sirve de una correa altamente elástica hecha en elastómero de gran resistencia. Pala fabricada a partir de una resina especial de poliolefina y cavidad para el pie hecha en caucho termoplástico.



BRACELET   BAND	XXS/S	S/XL
COD.	07001	07002



SIZE   TALLA	XXS/XS	XS/S	S/M	M/L	L/XL
SIZE   TALLA (EU)	32/35	36/38	39/41	42/44	45 /47
BLUE	71-14B/XXS-XS	71-14B/XS-S	71-14B/S-M	71-14B/M-L	71-14B/L-XL
YELLOW	71-14Y/XXS-XS	71-14Y/XS-S	71-14Y/S-M	71-14Y/M-L	71-14Y/L-XL



6 pieces/code  
6 unidades/código

# ZOOM

ITALIAN DESIGN

Open-heel fin adjustable to 6 different positions per size. Closure system using highly elastic and durable elastomer strap. The blade is made of a special polyolefin resin, and its innovative design guarantees fluid finning. Foot pocket in thermoplastic rubber.

Aleta de calzante abierto ajustable en 6 posiciones diferentes por talla. Sistema de cierre que se sirve de una correa altamente elástica hecha en elastómero de gran resistencia. La pala se ha realizado a partir de una resina especial de poliolefina, y su diseño innovador garantiza fluidez en el aleteado. Cavidad para el pie hecha a partir de caucho termoplástico.

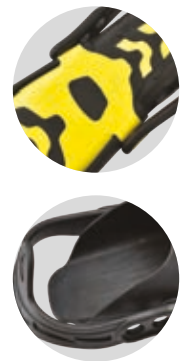

STRAP   CORREA	XXS/S	S/XL
COD.	07001	07002



SIZE   TALLA	XXS/XS	XS/S	S/M	M/L	L/ XL
SIZE   TALLA (EU)	32/35	36/38	39/41	42/44	45 /47
BLUE	71-41B/XXS-XS	71-41B/XS-S	71-41B/S-M	71-41B/M-L	71-41B/L-XL
YELLOW	71-41Y/XXS-XS	71-41Y/XS-S	71-41Y/S-M	71-41Y/M-L	71-41Y/L-XL
PINK	71-41P/XXS-XS	71-41P/XS-S	71-41P/S-M	-	-



6 pieces/code  
6 unidades/código



## VELA

ITALIAN DESIGN

Short fin designed for training in the pool.  
Ergonomic foot pocket and supple blade.  
Edge fully covered in rubber to prevent blows.  
Can also be used for snorkeling.

Aleta corta diseñada para entrenar en la piscina.  
Calzante ergonómico y pala flexible.  
Borde totalmente cubierto con goma para evitar impactos.  
También se puede usar para practicar esnórquel.



SIZE   TALLA (EU)	32/33	34/35	36/37	38/39
WHITE	71-46W/32-33	71-46W/34-35	71-46W/36-37	71-46W/38-39
BLUE	71-46B/32-33	71-46B/34-35	71-46B/36-37	71-46B/38-39
YELLOW	71-46Y/32-33	71-46Y/34-35	71-46Y/36-37	71-46Y/38-39
BLACK	71-46N/32-33	71-46N/34-35	71-46N/36-37	71-46N/38-39
CLEAR BLUE	71-46AZ/32-33	71-46AZ/34-35	71-46AZ/36-37	71-46AZ/38-39

SIZE   TALLA (EU)	40/41	42/43	44/45	46/47
WHITE	71-46W/40-41	71-46W/42-43	71-46W/44-45	71-46W/46-47
BLUE	71-46B/40-41	71-46B/42-43	71-46B/44-45	71-46B/46-47
YELLOW	71-46Y/40-41	71-46Y/42-43	71-46Y/44-45	71-46Y/46-47
BLACK	71-46N/40-41	71-46N/42-43	71-46N/44-45	71-46N/46-47
CLEAR BLUE	71-46AZ/40-41	71-46AZ/42-43	71-46AZ/44-45	71-46AZ/46-47



6 pieces/code  
6 unidades/código

## VELA OH

ITALIAN DESIGN

Adjustable open-foot fin for snorkeling.  
Short blade ideal for snorkeling and training, available in 5 sizes, from 32-35 (XXS-XS) and 45-47 (L-XL).  
The fit can be adjusted to 6 positions per size, for maximum stability and comfort.  
Strap made of highly flexible thermoplastic elastomer.  
Foot pocket in soft thermoplastic rubber and blade in special polyolefin resin to offer excellent performance without special exertion.

Aleta regulable de zapato abierto para esnórquel.  
Pala corta ideal para esnórquel y entrenamiento, disponible en 5 tallas, del 32-35 (XXS-XS) al 45-47 (L-XL).  
Regulación del zapato en 6 posiciones en cada talla para la máxima estabilidad y confort durante el uso.  
Correa fabricada en elastómero termoplástico de alta elasticidad.  
Zapato de goma blanda termoplástica y pala en resina especial de poliolefina para ofrecer prestaciones óptimas sin esfuerzo.



SIZE   TALLA	XXS/XS	XS/S	S/M	M/L	L/XL
WHITE	71-47W/XXS-XS	71-47W/XS-S	71-47W/S-M	71-47W/M-L	71-47W/L-XL
BLUE	71-47B/XXS-XS	71-47B/XS-S	71-47B/S-M	71-47B/M-L	71-47B/L-XL
BLACK	71-47N/XXS-XS	71-47N/XS-S	71-47N/S-M	71-47N/M-L	71-47N/L-XL

SIZE   TALLA (EU)	32/35	36/38	39/41	42/44	45 /47
-------------------	-------	-------	-------	-------	--------

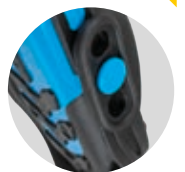

6 pieces/code  
6 unidades/código







## Snorkeling set | Conjunto de esnórquel

Moving among rich, colorful reefs exploring the beauties of the sea? You can, easily and enjoyably, with SEAC® snorkeling sets. Whether you're shopping for adults or kids, one lens or two, full-foot or open-heel fins, our company has the right set to meet your needs.

¿Le gusta disfrutar de los ricos y coloridos arrecifes explorando las bellezas del mar? Con los sets para esnórquel de SEAC®, ahora puede hacerlo de manera fácil y divertida. Ya sea que busque productos para adultos o para niños, máscaras de uno o dos lentes, aletas de pie abierto o cerrado, nuestra empresa puede brindarle el conjunto perfecto para sus necesidades.





# SET TRIS SPRINT DRY

ITALIAN DESIGN



snorkeling|2020



Set includes Sprint open heel fins, a Giglio silicone mask, and a Fast Tech Dry snorkel with valve.

Conjunto compuesto por aletas Sprint y calzante abierto, máscara Giglio hecha de silicona y tubo de esnórquel Fast Tech Dry con válvula.

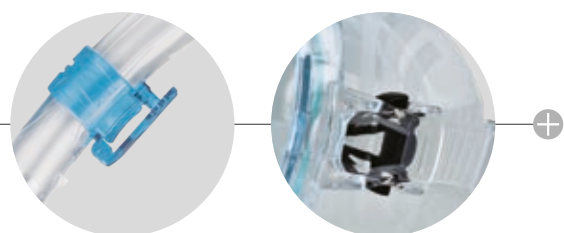

SIZE   TALLA	32/35	36/38	39/41	42/44	45/47
MODEL   MODELO	JR	MD	AD	AD	AD
COD.	89-30B/32-35	89-30B/36-38	89-30B/39-41	89-30B/42-44	89-30B/45-47

## SET ZOOM AD

ITALIAN DESIGN



Set includes Zoom open-heel fins, an Elba silicone mask, and a Fast Tech snorkel with valve.

El conjunto incluye: Aletas Zoom de calzante abierto, una máscara Elba hecha en silicona y el tubo de esnórquel Fast Tech con válvula.

SIZE   TALLA	39/41	42/44	45/47
■ BLUE	89-29B/39-41	89-29B/42-44	89-29B/45-47

## SET ZOOM MD

ITALIAN DESIGN



Set includes Zoom open-heel fins, an Elba MD silicone mask, and a Tribe snorkel with valve.

Este conjunto incluye unas aletas Zoom de calzante abierto, una máscara Elba MD hecha en silicona y el tubo de esnórquel Tribe con válvula.

SIZE   TALLA	36/38
■ BLUE	89-29B/36-38

## SET ZOOM JR

ITALIAN DESIGN



Set includes Zoom open-heel fins, a Bella silicone mask, and a Tribe snorkel with valve.

Este conjunto incluye unas aletas Zoom de calzante abierto, una máscara Bella de silicona y el tubo de esnórquel Tribe con válvula.

SIZE   TALLA	32/35
■ BLUE	89-29B/32-35

## SET SPINTA AD

ITALIAN DESIGN



Set includes Spinta full-foot fins, a Panarea SLT mask, and a Flash snorkel.

Este conjunto incluye unas aletas Spinta de calzante cerrado, una máscara Elba de silicona y el tubo de esnórquel Flash.

SIZE   TALLA	40/41	42/43	44/45	46/47
■ BLUE	89-58B/40-41	89-58B/42-43	89-58B/44-45	89-58B/46-47

## SET SPINTA MD

ITALIAN DESIGN



Set includes Spinta full-foot fins, a Elba MD silicone mask, and a Mini Flash snorkel.

Este conjunto incluye unas aletas Spinta de calzante cerrado, una máscara Elba MD de silicona y el tubo de esnórquel Mini Flash.

SIZE   TALLA	34/35	36/37	38/39
■ BLUE	89-58B/34-35	89-58B/36-37	89-58B/38-39

## SET SPINTA JR

ITALIAN DESIGN



Set includes Spinta full-foot fins, a Bella silicone mask, and a Mini Flash snorkel.

Este conjunto incluye unas aletas Spinta de calzante cerrado, una máscara Bella de silicona y el tubo de esnórquel Mini Flash.

SIZE   TALLA	28/30	31/33
■ BLUE	89-58B/28-30	89-58B/31-33



## SET ELBA

ITALIAN DESIGN



NEW COLOR



Set includes Elba dual-lens silicone mask and Fast snorkel with valve (Jet snorkel for S/BL).

Este conjunto incluye una máscara Elba de doble lente hecha en silicona y el tubo de esnórquel Fast Tech con válvula (Snorkel Jet para S/BL).

MODEL   MODELO	S/KL	S/BL
BLUE	89-73B	-
YELLOW	89-73Y	-
BLACK	-	89-53N



## SET GIGLIO

ITALIAN DESIGN



Set includes single-lens Giglio clear silicone mask and Fast with valve.

Este conjunto incluye una máscara transparente Giglio con un lente y hecha en silicona, y el tubo de esnórquel Fast Tech con válvula.

MODEL   MODELO	S/KL	S/BL
BLUE	89-71B	-
YELLOW	89-71Y	-
BLACK	-	89-55N



## SET EXTREME | SET EXTREME SBL

ITALIAN DESIGN



Set including Extreme silicone mask and Bora HD snorkel with anti-splash top and valve (Top Flex for the S/BL version).

Conjunto compuesto por máscara Extreme de silicona y esnórquel Bora HD con válvula y parte superior antisalpicaduras (Top Flex para la versión S/BL).

MODEL   MODELO	S/KL	S/BL
BLUE	89-42BC	-
YELLOW	89-42Y	-
BLACK	-	89-24N

## SET ELBA VALVE MD

ITALIAN DESIGN



Set includes Elba MD clear silicone mask and Tribe snorkel with valve.

Este conjunto incluye una máscara transparente Elba MD de silicona y el tubo de esnórquel Tribe con válvula.

SET ELBA VALVE MD	S/KL
BLUE	89-72B
YELLOW	89-72Y

## SET GIGLIO MD VALVE

ITALIAN DESIGN



Set includes Giglio MD clear silicone mask and Tribe snorkel with valve.

Este conjunto incluye una máscara transparente Giglio MD de silicona y el tubo de esnórquel Tribe con válvula.

MODEL   MODELO	S/KL
■ BLUE	89-70B
■ YELLOW	89-70Y

## SET BELLA COLOR

ITALIAN DESIGN



Set includes Bella colored silicone mask and Tribe snorkel with valve and anti-splash top.

Este conjunto incluye una máscara de color Bella de silicona, y el tubo de esnórquel Tribe con válvula y sistema antisplacaduras en la parte superior.

MODEL   MODELO	S/COL
■ CLEAR BLUE	89-51AZ
■ PINK	89-52P



## SET BELLA

ITALIAN DESIGN



Set includes Bella clear silicone mask and Tribe snorkel with anti-splash top.

Este conjunto incluye una máscara transparente Bella de silicona y el tubo de esnórquel Miniflash con sistema antisalpicaduras en la parte superior.

COD. 89-35A

## SET MARINA

ITALIAN DESIGN



Set includes Marina silicone mask and Z Piccolo snorkel.

Este conjunto incluye una máscara Marina de silicona y un tubo de esnórquel Z Piccolo.

MODEL   MODELO	S/KL
BLUE	9467B
YELLOW	9467Y
PINK	9467P



## SET BAIA

ITALIAN DESIGN



Set includes Baia mask and Z Piccolo snorkel.

Este conjunto incluye una máscara Baia y un tubo de esnórquel Z Piccolo.

MODEL   MODELO	SLT
 AQUAMARINE	89-27A
 PINK	89-28P



## SET ISCHIA

ITALIAN DESIGN



Set includes Ischia clear SLT mask and Z Grande snorkel with PVC mouthpiece.

Este conjunto incluye una máscara transparente Ischia de SLT y el tubo de esnórquel Z Grande con boquilla de PVC.

MODEL   MODELO	SLT
 BLUE	89-41B
 YELLOW	89-41Y

## SET ISCHIA MD

ITALIAN DESIGN



Set includes Ischia MD clear SLT mask and Z Piccolo snorkel with PVC mouthpiece.

Este conjunto incluye una máscara transparente Ischia MD de SLT y el tubo de esnórquel Z Piccolo con boquilla de PVC.

MODEL   MODELO	SLT
BLUE	89-34B
YELLOW	89-34Y

## SET PANAREA

ITALIAN DESIGN



Set includes Panarea clear SLT mask and Z Grande snorkel with PVC mouthpiece.

Este conjunto incluye una máscara transparente Panarea de SLT y el tubo de esnórquel Z Grande con boquilla de PVC.

MODEL   MODELO	SLT
BLUE	89-40B
YELLOW	89-40Y



## SET PANAREA MD

ITALIAN DESIGN



Set includes Panarea MD clear SLT mask and Z Piccolo snorkel with PVC mouthpiece.

Este conjunto incluye una máscara transparente Panarea MD de SLT y el tubo de esnórquel Z Piccolo con boquilla de PVC.

MODEL   MODELO	SLT
■ BLUE	89-33B
■ YELLOW	89-33Y

## SET PROCIDA COLOR

ITALIAN DESIGN



Set includes Procida SLT mask and Z Piccolo snorkel with PVC mouthpiece.

Conjunto compuesto por una máscara Procida de SLT y el tubo de esnórquel Minijet con boquilla de silicona.

COD. 89-64AZ

## SET MARINA SLT

ITALIAN DESIGN



Set includes Marina clear SLT mask and Z Piccolo snorkel.

Este conjunto incluye una máscara transparente Marina de SLT y el tubo de esnórquel Z Piccolo.

MODEL   MODELO	SLT
■ BLUE	9468B
■ YELLOW	9468Y
■ PINK	9468P







## Rash guard

SEAC® suits and rash guards are made for diving, snorkeling, surfing, kite surfing, and all the other water sports. They're practical, comfy, and quick and easy to put on any time you want to enjoy nimble freedom of movement.

Los trajes y las camisetas «rash guard» SEAC® están pensados para deportes que van de las inmersiones o del esnórquel al surf, al kitesurf y a todos los deportes acuáticos. Prácticos, cómodos y rápidos de poner en cualquier situación, para poder estar libre y realizar movimientos rápidos.





# RAA EVO - RAA KID EVO

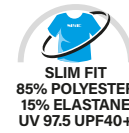

Scratch-resistant rash guard and shorts designed for swimming and snorkeling. Protects against UV rays with UPF40+ sun protection. Flat stitching, a body-hugging cut, and excellent elasticity for maximum comfort while recreating. 85% nylon - 15% Spandex.

Rash guard y Pantalones cortos resistentes a los arañazos, diseñados para nadar y practicar esnórquel. Ofrece protección contra los rayos UV con UPF+40. Costura plana, corte ajustado y elasticidad óptima para ofrecer el máximo confort en deportes recreativos. 85% nailon - 15% Spandex.

RAA LONG EVO	XS	S	M	L	XL	XXL	XXXL	XXXXL
MAN   HOMBRE	9316/01	9316/02	9316/03	9316/04	9316/05	9316/06	9316/07	9316/08
LADY   MUJER	155-1/XS	155-1/S	155-1/M	155-1/L	155-1/XL	-	-	-

RAA SHORT EVO	XS	S	M	L	XL	XXL	XXXL	XXXXL
MAN   HOMBRE	9317/01	9317/02	9317/03	9317/04	9317/05	9317/06	9317/07	9317/08
LADY   MUJER	155-3/XS	155-3/S	155-3/M	155-3/L	155-3/XL	-	-	-

RAA PANT EVO	XS	S	M	L	XL	XXL	XXXL	XXXXL
MAN   HOMBRE	9318/01	9318/02	9318/03	9318/04	9318/05	9318/06	9318/07	9318/08
LADY   MUJER	155-5/XS	155-5/S	155-5/M	155-5/L	155-5/XL	-	-	-

RAA KID EVO	6	8	10	12
RAA LONG KID EVO	155-2/6	155-2/8	155-2/10	155-2/12
RAA SHORT KID EVO	155-4/6	155-4/8	155-4/10	155-4/12
RAA PANT KID EVO	155-6/6	155-6/8	155-6/10	155-6/12

## T-SUN LONG

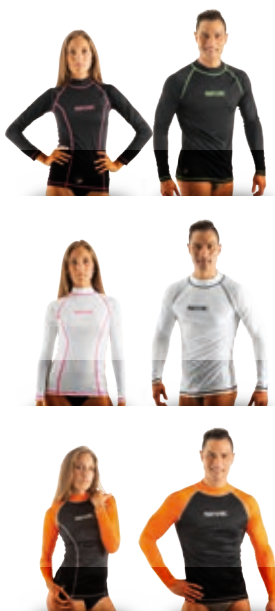

NEW COLOR



SIZE   TALLA		XXS	XS	S	M	L	XL	XXL	XXXL
MAN HOMBRE	BLACK/GREEN	155-9/XXS	155-9/XS	155-9/S	155-9/M	155-9/L	155-9/XL	155-9/XXL	155-9/XXXL
	WHITE/BLACK	155-14/XXS	155-14/XS	155-14/S	155-14/M	155-14/L	155-14/XL	155-14/XXL	155-14/XXXL
	BLACK/ORANGE	155-24/XXS	155-24/XS	155-24/S	155-24/M	155-24/L	155-24/XL	155-24/XXL	155-24/XXXL
LADY MUJER	BLACK/PINK	-	155-11/XS	155-11/S	155-11/M	155-11/L	155-11/XL	-	-
	WHITE/PINK	-	155-15/XS	155-15/S	155-15/M	155-15/L	155-15/XL	-	-
	BLACK/ORANGE	-	155-16/XS	155-16/S	155-16/M	155-16/L	155-16/XL	-	-

## T-SUN SHORT

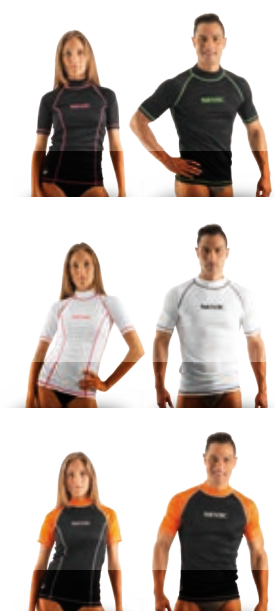

NEW COLOR



SIZE   TALLA		XXS	XS	S	M	L	XL	XXL	XXXL
MAN HOMBRE	BK/GREEN	155-17/XXS	155-17/XS	155-17/S	155-17/M	155-17/L	155-17/XL	155-17/XXL	155-17/XXXL
	WHITE/BK	155-22/XXS	155-22/XS	155-22/S	155-22/M	155-22/L	155-22/XL	155-22/XXL	155-22/XXXL
	BK/ORANGE	155-18/XXS	155-18/XS	155-18/S	155-18/M	155-18/L	155-18/XL	155-18/XXL	155-18/XXXL
LADY MUJER	BK/PINK	-	155-19/XS	155-19/S	155-19/M	155-19/L	155-19/XL	-	-
	WHITE/PINK	-	155-23/XS	155-23/S	155-23/M	155-23/L	155-23/XL	-	-
	BK/ORANGE	-	155-16LNO/XS	155-16LNO/S	155-16LNO/M	155-16LNO/L	155-16LNO/XL	-	-

## T-SUN LONG KID - T-SUN SHORT KID



T-SUN LONG KID		3	5	7	9	11
	CLEAR BLUE	155-12/3	155-12/5	155-12/7	155-12/9	155-12/11
	PINK	155-13/3	155-13/5	155-13/7	155-13/9	155-13/11

T-SUN SHORT KID		3	5	7	9	11
	CLEAR BLUE	155-20/3	155-20/5	155-20/7	155-20/9	155-20/11
	PINK	155-21/3	155-21/5	155-21/7	155-21/9	155-21/11

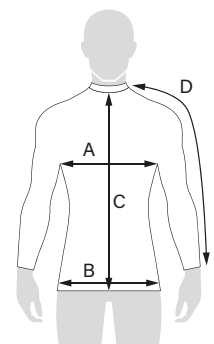

## RASH GUARD SIZE TABLE

### TABLA DE TALLAS PARA RASH GUARDS

AGE   EDAD	1/2 CHEST 1/2 PECHO A (cm)	1/2 HIPS 1/2 CADERAS B (cm)	TORSO LENGTH LONGITUD DEL TORSO C (cm)	SHORT SLEEVE MANGA CORTA D (cm)	LONG SLEEVE MANGA LARGA D (cm)
3-4	29	30	43	20	45
5-6	31	32	47	22	49
7-8	33	34	51	24	53
9-10	35.5	37	57	26	57
11-12	37	38	58	28	61
13-14	39	40	61	30	65



## Accessories | Accesorios

SEAC's snorkeling line is not limited just to products for the water. With a wide selection of dry bags, technical bags, reef shoes, and various accessories, we're by your side everywhere you go!

La línea para esnórquel de SEAC® no se limita exclusivamente a productos sólo para el agua. Con una amplia selección de bolsas estancas, bolsas técnicas, calzado para arrecife y diversos accesorios, estamos aquí para avanzar contigo allá donde vayas.



# REEF



6 pieces/unit  
6 unidades/código



Neoprene shoe with reinforced rubber sole.

Escarpín de neopreno con suela de goma reforzada.

SIZE   TALLA	28	29	30	31	32	33	34	35	36	37
■ BLUE	3848/28	3848/29	3848/30	3848/31	3848/32	3848/33	3848/34	3848/35	3849/36	3849/37
■ GREY	150-1G/28	150-1G/29	150-1G/30	150-1G/31	150-1G/32	150-1G/33	150-1G/34	150-1G/35	150-1G/36	150-1G/37
	38	39	40	41	42	43	44	45	46	
■ BLUE	3849/38	3849/39	3849/40	3849/41	3849/42	3849/43	3849/44	3849/45	3849/46	
■ GREY	150-1G/38	150-1G/39	150-1G/40	150-1G/41	150-1G/42	150-1G/43	150-1G/44	150-1G/45	150-1G/46	

# HAWAII



6 pieces/unit  
6 unidades/código



Neoprene shoe with reinforced rubber sole.

Escarpín de neopreno con suela de goma reforzada.

SIZE   TALLA	28	29	30	31	32	33	
COD.	150-11WG/28	150-11WG/29	150-11WG/30	150-11WG/31	150-11WG/32	150-11WG/33	
	34	35	36	37	38	39	40
	150-11WG/34	150-11WG/35	150-11WG/36	150-11WG/37	150-11WG/38	150-11WG/39	150-11WG/40
	41	42	43	44	45	46	47
	150-11WG/41	150-11WG/42	150-11WG/43	150-11WG/44	150-11WG/45	150-11WG/46	150-11WG/47

**SAND**6 pieces/unit  
6 unidades/código

Neoprene shoe with reinforced rubber sole.

Escarpín de neopreno con suela de goma reforzada.

SIZE   TALLA	28	29	30	31	32	33	34
COD.	150-12WB/28	150-12WB/29	150-12WB/30	150-12WB/31	150-12WB/32	150-12WB/33	150-12WB/34
	35	36	37	38	39	40	41
	150-12WB/35	150-12WB/36	150-12WB/37	150-12WB/38	150-12WB/39	150-12WB/40	150-12WB/41
	42	43	44	45	46		
	150-12WB/42	150-12WB/43	150-12WB/44	150-12WB/45	150-12WB/46		

**RAINBOW JR LIGHT**6 pieces/unit  
6 unidades/código

Neoprene shoe with reinforced rubber sole.

Escarpín de neopreno con suela de goma reforzada.

SIZE   TALLA	22	23	24	25	26	27	28
COD.	150-10A/22	150-10A/23	150-10A/24	150-10A/25	150-10A/26	150-10A/27	150-10A/28
	29	30	31	32	33	34	35
	150-10A/29	150-10A/30	150-10A/31	150-10A/32	150-10A/33	150-10A/34	150-10A/35



# MALAGA



6 pieces/unit  
6 unidades/código

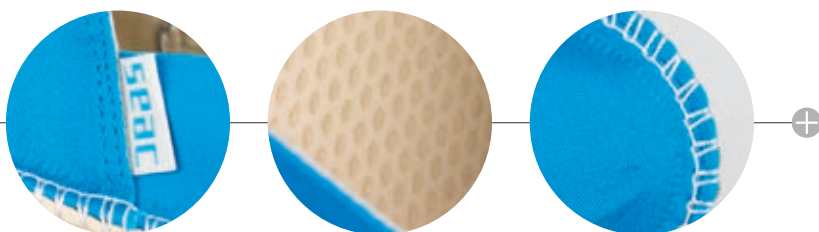

Shoe with soft non-slip EVA sole. Cotton upper. Extremely lightweight and comfortable. Available in two colors.

Calzado con suela de EVA suave y anti-deslizante. Parte superior de algodón. Extremadamente liviano y cómodo. Disponible en dos colores.

SIZE   TALLA	35	36	37	38	39	40
■ BLUE	150-15AZ/35	150-15AZ/36	150-15/AZ37	150-15AZ/38	150-15AZ/39	150-15AZ/40
□ WHITE	150-15W/35	150-15W/36	150-15W/37	150-15W/38	150-15W/39	150-15W/40

SIZE   TALLA	41	42	43	44	45	46
■ BLUE	150-15AZ/41	150-15AZ/42	150-15AZ/43	150-15AZ/44	150-15AZ/45	150-15AZ/46
□ WHITE	150-15W/41	150-15W/42	150-15W/43	150-15W/44	150-15W/45	150-15W/46

## MAUI

Take Seac® style with you everywhere, with the insanely comfortable MAUI flip flops.

- The anti-slip rubber sole varies in thickness to achieve maximum comfort.
- Lightweight material is resistant to water and changes in temperature.
- Seac® logo on the straps and upper sole.
- Available in 4 colors

Lleve el estilo Seac® con usted a todos lados, con las nuevas e increíblemente cómodas chanclas MAUI.

- La suela de goma anti-deslizamiento varía en espesor, para lograr el máximo confort.
- El material liviano es resistente al agua y a los cambios en la temperatura.
- El logo de Seac® se encuentra en las tiras y la parte superior de la suela.
- Disponibles en 4 colores



6 pieces/unit  
6 unidades/código

SIZE   TALLA	33/34	35/36	37/38	39/40
ROYAL/WHITE	150-13BW/33-34	150-13BW/35-36	150-13BW/37-38	150-13BW/39-40
NAVY/PURPLE	150-13BF/33-34	150-13BF/35-36	150-13BF/37-38	150-13BF/39-40
BLACK/AZURE	150-13NBC/33-34	150-13NBC/35-36	150-13NBC/37-38	150-13NBC/39-40
GREEN/YELLOW	150-13VY/33-34	150-13VY/35-36	150-13VY/37-38	150-13VY/39-40

SIZE   TALLA	41/42	43/44	45/46	47/48
ROYAL/WHITE	150-13BW/41-42	150-13BW/43-44	150-13BW/45-46	150-13BW/47-48
NAVY/PURPLE	150-13BF/41-42	-	-	-
BLACK/AZURE	150-13NBC/41-42	150-13NBC/43-44	150-13NBC/45-46	150-13NBC/47-48
GREEN/YELLOW	150-13VY/41-42	150-13VY/43-44	150-13VY/45-46	150-13VY/47-48



## OHAU

At home, in the pool, in the sea. Enjoy your free time with Seac® OAHU flip flops.

- Lightweight anti-slip rubber sole.
- Material resistant to water and changes in temperature.
- Available in 4 colors with Seac® logo on the straps.

En casa, en la piscina, en el mar. Disfrute de su tiempo libre con las chanclas OAHU de Seac®.

- Suela de goma liviana anti-deslizamiento.
- Material resistente al agua y a los cambios en la temperatura.
- Disponibles en 4 colores con el logo de Seac® en las tiras.



6 pieces/unit  
6 unidades/código

SIZE   TALLA	33/34	35/36	37/38	39/40
WHITE	150-14W/33-34	150-14W/35-36	150-14W/37-38	150-14W/39-40
WHITE/AZURE	150-14WB/33-34	150-14WB/35-36	150-14WB/37-38	150-14WB/39-40
NAVY/YELLOW	150-14BY/33-34	150-14BY/35-36	150-14BY/37-38	150-14BY/39-40
BLACK/GREY	150-14NG/33-34	150-14NG/35-36	150-14NG/37-38	150-14NG/39-40

SIZE   TALLA	41/42	43/44	45/46	47/48
WHITE	150-14W/41-42	150-14W/43-44	150-14W/45-46	150-14W/47-48
WHITE/AZURE	150-14WB/41-42	150-14WB/43-44	150-14WB/45-46	150-14WB/47-48
NAVY/YELLOW	150-14BY/41-42	150-14BY/43-44	150-14BY/45-46	150-14BY/47-48
BLACK/GREY	150-14NG/41-42	150-14NG/43-44	150-14NG/45-46	150-14NG/47-48



# CHRONOS

Plastic case and rubber strap.  
Available in three colors.  
Water resistant to 100 mt.

Carcasa de plástico y correa de goma.  
Disponible en tres colores.  
Resistente al agua hasta 100 metros.



CHRONOS		
	BLUE	147-4B
	BLACK	147-4N
	RED	147-4R



# CLASSIC

Stainless steel case and rubber strap.  
Available in 2 colors.  
Water resistant to 100 mt.

Carcasa de plástico y correa de goma.  
Disponible en 2 colores.  
Resistente al agua hasta 100 metros.

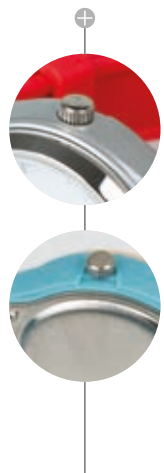

CLASSIC		
	AQUAMARINE	147-3AZ
	RED	147-3CO









## SPORTY

SPORTY is the new watch by SEAC® for active people. Stainless steel/resin case and rubber strap. Available in 4 colors. Water resistant 100 mt.

SPORTY es el nuevo reloj SEAC® para personas activas. Caja de acero inoxidable / resina y correa de caucho. Disponible en 4 colores. Resistente al agua 100 mt.



SPORTY		
	BLUE	147-1B
	MILITARY GREEN	147-1VM
	ORANGE	147-1O
	CLEAR BLUE	147-1AZ





## MOVER

Always on time even on the beach with SEAC® MOVER. Stainless steel case and rubber strap. Available in 2 colors. Water resistant 100 mt.

Siempre a tiempo, incluso en la playa con SEAC® MOVER. Caja de acero inoxidable y correa de caucho. Disponible en 2 colores. Resistente al agua 100 mt.



MOVER		
	BLACK/RED	147-2RN
	BLACK	147-2N



## ANTIFOG BIO GEL

MADE IN ITALY



24 pieces/unit  
24 unidades/código

VERSION   VERSIÓN	15 ml	30 ml	DISPLAY
COD.	111-99	1608	300-15

## SNORKELING BAG

Carry bags, ideal for transporting your snorkeling gear.

Bolsas ideales para llevar el equipo de esnórquel.



4800088



711



C20066

VERSION   VERSIÓN	SET BIS 24X51 cm	MESH	30X60 cm
COD.	4800088	711	C20066

## BEACH MAT



BEACH MAT	
COD.	152-29B
PACKAGE   PAQUETE	(6 PIECES   6 PIEZAS)
SIZE   TALLA	180 X 90 cm

## PHONE CASE



**NEW**



PHONE CASE	
<input type="checkbox"/> WHITE	92-28W
<input checked="" type="checkbox"/> BLACK	92-28N

snorkeling | 2020

## SNORKELING VEST



25 pieces/unit  
25 unidades/código



Snorkeling vest with oral inflation valve and manual air dump.

Chaleco para esnórquel con válvula de inflador bucal y válvula de salida de aire manual.

SIZE   TALLA	S - M	L - XL
COD.	86602/S	86604/L



FREEDIVING 2020



## Computers | Ordenadores

SEAC® freediving computers, designed in Italy, are conceived to monitor performance and optimal recovery times, to keep you consistently at your best and delivering the most, in complete safety, dive after dive.

Los ordenadores para apnea de SEAC®, diseñados en Italia, fueron concebidos para monitorear el desempeño y los tiempos de recuperación óptimos, de modo de mantener al buceador siempre en su mejor estado y en condiciones absolutamente seguras, inmersión tras inmersión.





# DRIVER

ITALIAN DESIGN



New wrist-mount computer for freediving, able to constantly monitor performance, dive values, and recovery times. Extensive internal memory, with logbook downloadable to PC or Mac.

- Dive/ascent speeds, temperature, total dive time, and depth, all on the same screen.
- MSRT function (minimum surface recovery time) for the diver's safety.
- Setting for fresh or salt water.
- Extensive logbook memory divided into 100 sessions and 250 individual dives.
- Download and synchronize using software for PC and Mac.
- User-replaceable battery.
- Illuminated and sound alarms can be deactivated.

Nuevo ordenador para apnea: se coloca en la muñeca y es capaz de monitorear de manera constante el desempeño, los valores de inmersión y los tiempos de recuperación. Memoria interna amplia, con bitácora que puede descargarse a una PC o Mac.

- Velocidades de inmersión/ascenso, temperatura, tiempo total de inmersión, y profundidad, todo en la misma pantalla.
- Función MSRT (tiempo de recuperación mínimo en superficie) para mayor seguridad del buceador.
- Posibilidad de configurar el ordenador para agua dulce o salada.
- Amplia memoria de la bitácora, dividida en sesiones e inmersiones individuales.
- Se puede descargar y sincronizar usando un software para PC y Mac.
- Batería sustituible por el usuario.
- Las alarmas con sonido e iluminación pueden ser desactivadas.



COLOR

BLACK

GREEN

COD.

160-3N

160-3V



# PARTNER

ITALIAN DESIGN



Recreational wrist-mount dive computers with easy to use, backlit display.

- Records your freediving sessions up to 99 dives.
- Stopwatch and countdown function.
- Dive time, descent/ascent time, depth, and temperature on the same screen.
- Standard CR2032 battery.
- Maximum depth: 100 m

- Ordenadores de buceo recreativo para colocar en la muñeca, con una pantalla iluminada y fácil de usar.
- Registra sus sesiones de buceo en apnea, hasta 99 inmersiones.
- Función de cronómetro y cuenta regresiva.
- Tiempo de inmersión, tiempo de descenso/ascenso, profundidad y temperatura en la misma pantalla.
- Batería CR2032 estándar.



COLOR		
	BLACK	RED
COD.	160-4N	160-4R

## TECHNICAL CHARACTERISTICS | CARACTERÍSTICAS TÉCNICAS

	DRIVER	PARTNER
DIVE MODE   MODO DIVE	AUTO AND MANUAL AUTOMÁTICO Y MANUAL	MANUAL MANUAL
DESCENT/ASCENT RATE VELOCIDAD DE DESCENSO / ASCENSO	✓	-
MSRT FUNCTION   FUNCIÓN MSRT	✓	-
MAXIMUM DEPTH PROFUNDIDAD MÁXIMA	100 m	100 m
DIVE TIME	✓	✓
SURFACE TIME	✓	✓
TEMPERATURE   TEMPERATURA	-20 ▪ +70 C°	-9.9 ▪ +60 C°
STOPWATCH FUNCTION FUNCIÓN DE CRONÓMETRO	✓	✓
COUNTDOWN FUNCTION FUNCIÓN DE COUNTDOWN	✓	✓
PACER FUNCTION   FUNCIÓN DE PACER	-	✓
WATER ADAPTATION ADAPTACIÓN AL AGUA	MANUAL (SALT OR FRESH) MANUAL (AGUA SALADA O AGUA DULCE)	-
TIME/DEPTH ALARM ALARMAS DE TIEMPO / PROFUNDIDAD	ON/OFF	✓
DIVE MODE HYDRATION REMINDER RECORDATORIO DE HIDRATACIÓN	✓	-
DOUBLE TIME ZONES DOBLE HUSO HORARIO	✓	✓
ALARM   ALARMA	✓	✓
BACKLIGHTING RETROILUMINACIÓN	✓	✓
LOGBOOK	100 SESSIONS / 250 DIVES (UP TO 199 DIVES PER SESSION) 100 SESIONES / 250 INMERSIONES (MÁXIMO 199 INMERSIONES POR SESIÓN)	30 SESSIONS / 99 DIVES 30 SESIONES / 99 INMERSIONES
BATTERY   BATERÍA	REPLACEABLE   SUSTITUIBLE	REPLACEABLE   SUSTITUIBLE
PC/MAC CONNECTION INTERFAZ PC / MAC	✓	-
FIRMWARE UPDATES ACTUALIZACIONES DE SOFTWARE	✓	-

### USB CABLE FOR COMPUTER INTERFACE (DRIVER) CABLE USB PARA INTERFAZ DE LA COMPUTADORA (DRIVER)



COD. 163-11



## Wetsuits | Trajes húmedos

"Tailor-made" wetsuit line: this is the approach SEAC® uses to design and manufacture its line of suits for spearfishing and freediving. The anatomical, preformed cut that characterizes every model our company makes is the result of numerous computer processes, and was designed ad hoc based on a variety of requirements, including fit and the nature of the materials we use. We use only the finest neoprene when making our suits, and we pay careful attention to even the smallest details to make them a true second skin in the water. We even take care to store them at full length; they are only folded and packaged when they ship.

Línea de trajes húmedos "hechos a medida": este es el enfoque que SEAC utiliza para diseñar y confeccionar su línea de trajes para pesca submarina y buceo en apnea. El corte anatómico y ergonómico característico de cada uno de los modelos que nuestra empresa produce, es el resultado de numerosos procesos informáticos; asimismo, se diseñan internamente por nuestros expertos a partir de los diversos requisitos que se toman en consideración, entre los que se cuentan un buen ajuste y la naturaleza de los materiales que utilizamos. Utilizamos únicamente neopreno de la más alta calidad en la confección de nuestros trajes, y prestamos una cuidada atención al detalle incluso más pequeño para convertirlos en una verdadera segunda piel en el agua. Incluso tenemos el cuidado de almacenarlos estirados en toda su largada y solo se llegan a doblar y embalar en el momento del envío.





# GHOST

ITALIAN DESIGN



5 mm

7 mm

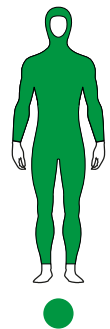

UltraStretch material

Superelastic two-piece camouflage neoprene suit. Exclusive SEAC® camouflage fabric in shades of dark brown, green, and orange.

Suit glued and blind stitched. Coated fabric on the outside and open-cell interior.

Anatomic and preformed cut on the arms/knees/back, featuring Aquastop around the face and at the wrists and ankles with the SSRS System (super-stretch round seal).

Jacket in 7 and 5 mm with incorporated hood, scratch-proof Powertext forearm guards, beaver tail closure with two plastic grommets and melco tape chest pad.

High-waisted pant, 5 mm thick with scratch-proof Powertext fabric knee pads. SEAC® exclusive superstretch camouflage fabric.

SEAC® exclusive superstretch camouflage fabric.

Traje de neopreno de dos piezas, superelástico y camuflado. Tela camuflada exclusiva de SEAC® en tonos verde y anaranjado. Traje ensamblado con cola y una costura invisible. Tejido de revestimiento en la parte exterior y celdas abiertas en la parte interior.

Corte anatómico y ergonómico en los brazos/rodillas/espalda y acabados Aquastop en la zona de la cara, además de en muñecas y tobillos gracias al sistema SSRS (sellado integral superelástico).

Chaqueta en 7 y 5 mm con capucha incorporada, protección en antebrazos de Powertext resistente a los arañazos, cierre en cola de castor con dos ojales de plástico y acolchado en el pecho en Melco Tape.

Pantalones de cintura alta y un grosor de 5 mm que incorporan unas rodilleras en tejido Powertext resistentes a los arañazos. Tela camuflada superelástica exclusiva de SEAC®

	SIZE   TALLA	S	M	L	XL	XXL	XXXL
ORANGE CAMO	JACKET   CHAQUETA 5 mm	1-96/S	1-96/M	1-96/L	1-96/XL	1-96/XXL	1-96/XXXL
	JACKET   CHAQUETA 7 mm	1-95/S	1-95/M	1-95/L	1-95/XL	1-95/XXL	1-95/XXXL
	PANT   PANTALONES 5 mm	1-102/S	1-102/M	1-102/L	1-102/XL	1-102/XXL	1-102/XXXL
GREEN CAMO	JACKET   CHAQUETA 5 mm	1-101/S	1-101/M	1-101/L	1-101/XL	1-101/XXL	1-101/XXXL
	JACKET   CHAQUETA 7 mm	1-100/S	1-100/M	1-100/L	1-100/XL	1-100/XXL	1-100/XXXL
	PANT   PANTALONES 5 mm	1-105/S	1-105/M	1-105/L	1-105/XL	1-105/XXL	1-105/XXXL

# GHOST

ITALIAN DESIGN



NEW



5 mm

7 mm

Superelastic two-piece camouflage neoprene suit. Exclusive SEAC® camouflage fabric in shades of dark brown, green, and orange.

Suit glued and blind stitched. Coated fabric on the outside and open-cell interior.

Anatomic and preformed cut on the arms/knees/back, featuring Aquastop around the face and at the wrists and ankles with the SSRS System (super-stretch round seal).

Jacket in 7 and 5 mm with incorporated hood, scratch-proof Powertext forearm guards, beaver tail closure with two plastic grommets and melco tape chest pad.

High-waisted pant, 5 mm thick with scratch-proof Powertext fabric knee pads.

SEAC® exclusive superstretch camouflage fabric.

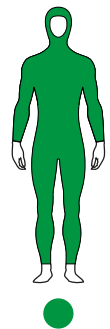

UltraStretch material

Traje de neopreno de dos piezas, superelástico y camuflado. Tela camuflada exclusiva de SEAC® en tonos de marrón oscuro. Traje ensamblado con cola y una costura invisible. Tejido de revestimiento en la parte exterior y celdas abiertas en la parte interior.

Corte anatómico y ergonómico en los brazos/rodillas/espalda y acabados Aquastop en la zona de la cara, además de en muñecas y tobillos gracias al sistema SSRS (sellado integral superelástico).

Chaqueta en 7 y 5 mm con capucha incorporada, protección en antebrazos de Powertext resistente a los arañazos, cierre en cola de castor con dos ojales de plástico y acolchado en el pecho en Melco Tape.

Pantalones de cintura alta y un grosor de 5 mm que incorporan unas rodilleras en tejido Powertext resistentes a los arañazos. Tela camuflada superelástica exclusiva de SEAC®

SIZE   TALLA	S	M	L	XL	XXL	XXXL	
 BROWN CAMO	JACKET   CHAQUETA 5 mm	1-99/S	1-99/M	1-99/L	1-99/XL	1-99/XXL	1-99/XXXL
	JACKET   CHAQUETA 7 mm	1-98/S	1-98/M	1-98/L	1-98/XL	1-98/XXL	1-98/XXXL
	PANT   PANTALONES 5 mm	1-104/S	1-104/M	1-104/L	1-104/XL	1-104/XXL	1-104/XXXL

# GANNET

ITALIAN DESIGN



3 mm

5 mm

7 mm

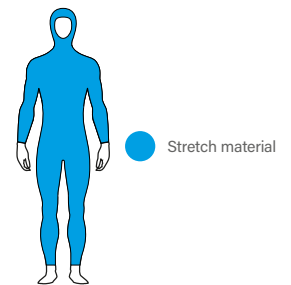
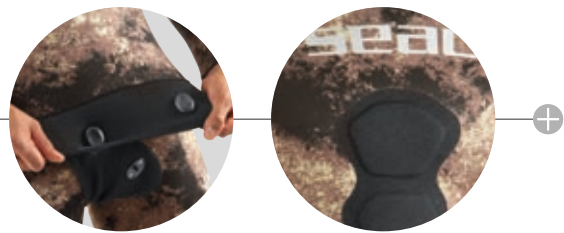

Two-piece spearfishing suit: hooded jacket and high-waisted pants.  
 Soft x-stretch neoprene with SEAC® exclusive camouflage fabric in shades of brown and green.  
 Suit glued and blind stitched. Coated fabric on the outside and open-cell interior.  
 Anatomical preformed cut on the arms, knees, back and raw cuts around the face, wrists, and ankles.  
 7, 5 and 3 mm Jacket, beaver tail closure with two plastic grommets, and melco tape chest pad.  
 High-waisted pant, 5 and 3 mm thick with scratch-proof Powertex fabric knee pads.

Traje de dos piezas para pesca submarina: chaqueta con capucha y pantalones de cintura alta.  
 Neopreno suave superelástico con tela camuflada exclusiva de SEAC®, en tonos de marrón y verde.  
 Traje ensamblado con cola y una costura invisible. Tejido de revestimiento en la parte exterior y celdas abiertas en la parte interior.  
 Corte ergonómico y anatómico en brazos, rodillas, espalda y corte limpio alrededor de la cara, las muñecas y los tobillos.  
 Chaqueta de 7, 5 y 3 mm, cierre de cola de castor con dos ojales de plástico y acolchado en el pecho en Melco Tape.  
 Pantalones de cintura alta y un grosor de 5 y 3 mm que incorporan unas rodilleras en tejido Powertex resistentes a los arañazos.

SIZE   TALLA		S	M	L	XL	XXL	XXXL
BROWN CAMO	JACKET   CHAQUETA 3 mm	1-112/S	1-112/M	1-112/L	1-112/XL	1-112/XXL	1-112/XXXL
	JACKET   CHAQUETA 5 mm	1-91/S	1-91/M	1-91/L	1-91/XL	1-91/XXL	1-91/XXXL
	JACKET   CHAQUETA 7 mm	1-111/S	1-111/M	1-111/L	1-111/XL	1-111/XXL	1-111/XXXL
	PANT   PANTALONES 3 mm	1-113/S	1-113/M	1-113/L	1-113/XL	1-113/XXL	1-113/XXXL
	PANT   PANTALONES 5 mm	1-93/S	1-93/M	1-93/L	1-93/XL	1-93/XXL	1-93/XXXL



# GANNET

ITALIAN DESIGN



5 mm

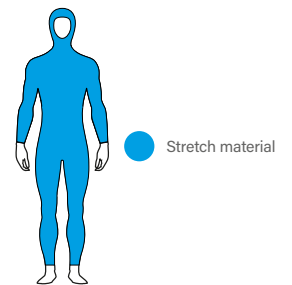
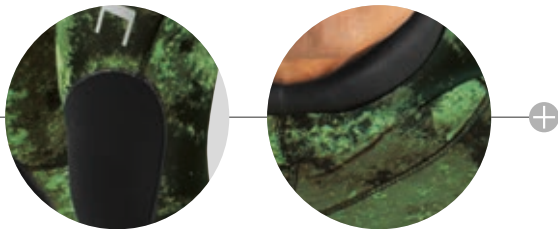

Two-piece spearfishing suit: hooded jacket and high-waisted pants.  
 Soft x-stretch neoprene with SEAC® exclusive camouflage fabric in shades of brown and green.  
 Suit glued and blind stitched. Coated fabric on the outside and open-cell interior.  
 Anatomical preformed cut on the arms, knees, back and raw cuts around the face, wrists, and ankles.  
 5 mm Jacket, beaver tail closure with two plastic grommets, and melco tape chest pad.  
 High-waisted pant, 5 mm thick with scratch-proof Powertex fabric knee pads.

Traje de dos piezas para pesca submarina: chaqueta con capucha y pantalones de cintura alta.  
 Neopreno suave superelástico con tela camuflada exclusiva de SEAC®, en tonos de marrón y verde.  
 Traje ensamblado con cola y una costura invisible. Tejido de revestimiento en la parte exterior y celdas abiertas en la parte interior.  
 Corte ergonómico y anatómico en brazos, rodillas, espalda y corte limpio alrededor de la cara, las muñecas y los tobillos.  
 Chaqueta de 5 mm, cierre de cola de castor con dos ojales de plástico y acolchado en el pecho en Melco Tape.  
 Pantalones de cintura alta y un grosor de 5 mm que incorporan unas rodilleras en tejido Powertex resistentes a los arañazos.

SIZE   TALLA		S	M	L	XL	XXL	XXXL
GREEN CAMO	JACKET   CHAQUETA 5 mm	1-92/S	1-92/M	1-92/L	1-92/XL	1-92/XXL	1-92/XXXL
	PANT   PANTALONES 5 mm	1-94/S	1-94/M	1-94/L	1-94/XL	1-94/XXL	1-94/XXXL

# BLACK SHARK

ITALIAN DESIGN



3 mm

5 mm

7 mm

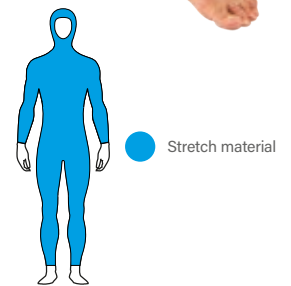
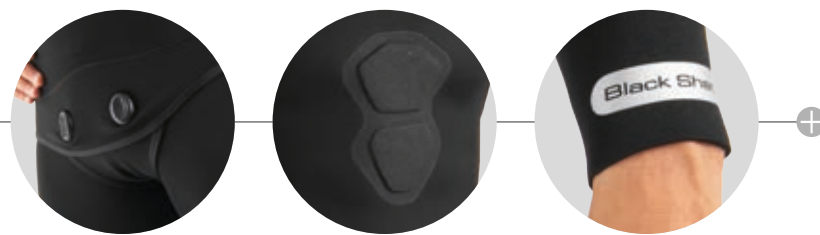

Two-piece spearfishing suit: hooded jacket and high-waisted pants.  
 Suit glued and blind stitched, in x-stretch single-lined neoprene and open-cell interior.  
 Anatomical preformed cut on the arms, knees, back and raw cuts around the face, wrists, and ankles.  
 7, 5 and 3 mm Jacket, beaver tail closure with two plastic grommets, and melco tape chest pad.  
 High-waisted pant, 7, 5 and 3 mm thick with scratch-proof Powertex fabric knee pads.

Traje de dos piezas para pesca submarina: chaqueta con capucha y pantalones de cintura alta.  
 Traje húmedo ensamblado con cola y costuras invisibles, en neopreno superelástico unicapa y celdas abiertas en la parte interior.  
 Corte ergonómico y anatómico en brazos, rodillas, espalda y corte limpio alrededor de la cara, las muñecas y los tobillos.  
 Chaqueta de 7, 5 y 3 mm, cierre de cola de castor con dos ojales de plástico y acolchado en el pecho en Melco Tape.  
 Pantalones de cintura alta y un grosor de 7, 5 y 3 mm que incorporan unas rodilleras en tejido Powertex resistentes a los arañazos.

SIZE   TALLA	S	M	L	XL	XXL	XXXL
BLACK SHARK 7 mm	1-106/S	1-106/M	1-106/L	1-106/XL	1-106/XXL	1-106/XXXL
BLACK SHARK 5 mm	1-107/S	1-107/M	1-107/L	1-107/XL	1-107/XXL	1-107/XXXL
BLACK SHARK 3 mm	1-108/S	1-108/M	1-108/L	1-108/XL	1-108/XXL	1-108/XXXL

# PROTECTION 9

ITALIAN DESIGN



Stretch material



9 mm



9 mm two-piece open cell suit consisting of a hooded jacket and Farmer John. This model features an anatomical, preformed cut on the arms and legs. Knee pads reinforced with latest-generation Supratex II. Jacket and Farmer John with 9 mm rubber. Arm and calves with preformed cut. Supratex knee pads.

Traje húmedo de dos piezas, de 9 mm de espesor, compuesto por una chaqueta con capucha y mono de tirantes. Hecho con un interior suave y liso de celda abierta, con corte anatómico y ergonómico en brazos y piernas. Rodilleras reforzadas con el tejido de nailón ergonómico de última generación Supratex II. Chaqueta y mono de tirantes confeccionados en goma de 9 mm. Corte ergonómico en brazos y gemelos. Rodilleras acolchadas en Supratex.

SIZE   TALLA	S	M	L	XL	XXL	XXXL
JACKET   CHAQUETA	1-66/S	1-66/M	1-66/L	1-66/XL	1-66/XXL	1-66/XXXL
SALOPETTE   FARMER JOHN	1-67/S	1-67/M	1-67/L	1-67/XL	1-67/XXL	1-67/XXXL

# ROYAL

ITALIAN DESIGN



3.5 mm

5 mm

7 mm



Suit double-lined in nylon, consisting of a jacket with incorporated hood and Farmer John in three thicknesses: 7 mm, 5 mm and 3.5 mm. Jacket with beaver tail closure with two plastic grommets and melco chest pad.

Overlock finishes around the face, wrists, and ankles. Preformed cut on the arms, calves, and back, so the suit adheres better to the body. New cut with Comfort Fit.

Traje doble capa hecho de nailón, compuesto por chaqueta con capucha incorporada y un mono, disponible en tres espesores diferentes: 7 mm, 5 mm y 3.5 mm. Chaqueta con cierre de cola de castor con dos ojales de plástico y acolchado en el pecho en Melco Tape. Acabado en overlock alrededor de la cara, muñecas y tobillos. Corte ergonómico en los brazos, gemelos y espalda, para un mejor ajuste pegado al cuerpo. Nuevo corte con Comfort Fit.

SIZE   TALLA	S	M	L	XL	XXL	XXXL
ROYAL 7 mm	1-82/S	1-82/M	1-82/L	1-82/XL	1-82/XXL	1-82/XXXL
ROYAL 5 mm	1-83/S	1-83/M	1-83/L	1-83/XL	1-83/XXL	1-83/XXXL
ROYAL 3.5 mm	1-84/S	1-84/M	1-84/L	1-84/XL	1-84/XXL	1-84/XXXL



# MAKAIRA

ITALIAN DESIGN



2 mm



AQUASTOP



freediving|2020

Two-piece wetsuit, with hooded jacket and high-waisted pants, in 2-mm double-lined neoprene with a Seac exclusive camo blue lining. Melco chest pad and reinforcements in 3D polyurethane on the knees and forearms. Lycra Seal Aquastop on the hood around the face and on the wrists and ankles. Closure system at the wrists and ankles with superelastic Lycra border. Ample elbow and knee pads in Print PU. Melco chest pad.

Traje húmedo de dos piezas compuesto de una chaqueta con capucha y pantalones de cintura alta, en neopreno de 2 mm de doble capa confeccionado en el exclusivo forro de camuflaje azul de Seac. Acolchado en el pecho con Melco y refuerzos de poliuretano 3D en las rodillas y antebrazos. Sellado Aquastop confeccionado en lycra en la capucha por la parte que bordea la cara, así como en muñecas y tobillos. Sistema de acabado en muñecas y tobillos mediante un reborde en lycra ultraelástica. Amplias almohadillas en codos y rodillas en PU estampado. Acolchado en pecho con el tejido Melco.

SIZE   TALLA	S	M	L	XL	XXL	XXXL
COD.	1-35/S	1-35/M	1-35/L	1-35/XL	1-35/XXL	1-35/XXXL

# BODY FIT CAMO

ITALIAN DESIGN



1.5 mm

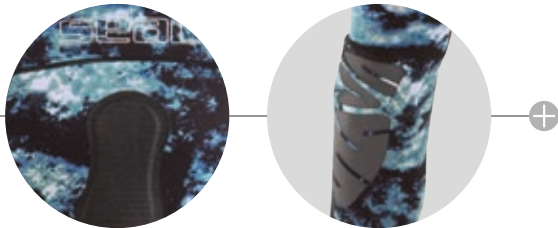

One-piece suit with rear zip in 1.5 mm double-lined neoprene. Exclusive outer coating in SEAC® green/blue camo. Melco chest pad and Tatex Print PU knee pads. Preformed cut for better adherence to the body. Rear zip with highly durable slider. Tatex Print PU knee pads. Chest pad in melco.

Traje de una sola pieza con cremallera en la espalda y confeccionado a partir de una doble capa de neopreno de 1,5 mm. Revestimiento en la parte exterior con el exclusivo tejido de camuflaje verde y azul de SEAC®. Acolchado en el pecho en Melco y en las rodilleras en estampado de PU Tatex. Corte ergonómico para una mejor adherencia al cuerpo. Cremallera en la espalda con un tirador hecho en un material resistente. Rodilleras acolchadas en estampado de PU Tatex. Acolchado en el pecho en Melco.

SIZE   TALLA	S	M	L	XL	XXL
COD.	1-8/S	1-8/M	1-8/L	1-8/XL	1-8/XXL

# PIRAÑA

ITALIAN DESIGN



91% POLYESTER  
9% ELASTANE

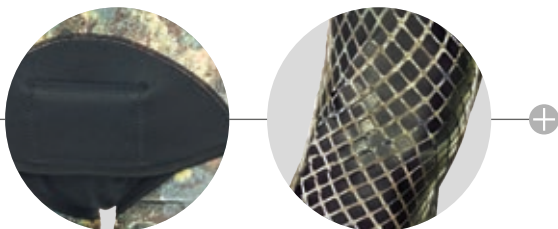

Two-piece suit composed of hooded jacket and high-waisted pants. Model entirely in Elastane fabric. Supratex-lined chest pad in 7 mm neoprene. Lycra finishing around the face, wrists, and ankles. Camouflage design in shades of green, yellow, and brown. 3D PU pads on the knees, elbows, and lower back. 7 mm Supratex chest pad. Beaver tail closure with Velcro.

Traje de dos piezas compuesto de una chaqueta con capucha y pantalones de cintura alta. Modelo íntegramente confeccionado en tejido Elastano con acolchado de poliuretano 3D en rodillas, codos y zona lumbar. Acolchado en la zona del pecho y forro de Supratex en un neopreno de 7 mm de grosor. Acabado en licra alrededor de la cara, muñecas y tobillos. Cierre en cola de castor con Velcro. Diseño de camuflaje en tonos de verde, amarillo y marrón. Acolchado en PU en rodillas, codos y zona lumbar. Acolchado en el pecho en Supratex de 7 mm. Cierre en cola de castor con Velcro.

SIZE   TALLA	S	M	L	XL	XXL	XXXL
COD.	1-37/S	1-37/M	1-37/L	1-37/XL	1-37/XXL	1-37/XXXL

# ENERGY

ITALIAN DESIGN



2 mm

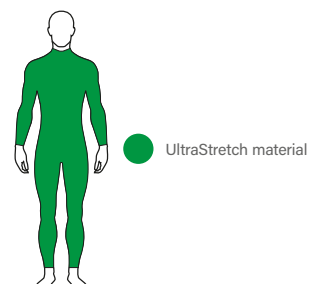

freediving|2020

Suit designed for freediving and swimming in open water, with an anatomical cut under the arms with no stitches for added comfort while swimming. Smooth Skin neoprene on the outside, 2 mm thick, glued and stitched to prevent water seepage, and fully lined with ultra-elastic fabric. Superelastic Smooth Skin collar and injection-hook Velcro closure to avoid damaging the suit. The innovative design, conceived to deliver the best performance, and the bright color on the arms and legs of Energy ensure maximum visibility on the surface when swimming in open water. Superelastic Smooth Skin neoprene. Suit glued and stitched for better thermal insulation. The innovative design is designed for maximum visibility on the surface.

Traje diseñado para la práctica del buceo en apnea y nadar en aguas abiertas, con un corte anatómico bajo los brazos sin costuras para incluso más comodidad al nadar. Neopreno Smooth Skin de 2 mm por la parte exterior, cosido y ensamblado para evitar el filtrado de agua y forrado con un revestimiento de tela ultraelástica. Cuello en Smooth Skin ultraelástico y cierre con Velcro Injection Hook, que evita causar daños en el traje. Este diseño innovador, concebido para ofrecer el mejor rendimiento y el color brillante en brazos y piernas de Energy, garantizan la máxima visibilidad del usuario en la superficie al nadar en aguas abiertas. Neopreno extraelástico Smooth Skin. Traje cosido y ensamblado con cola para un mejor aislamiento térmico. Su diseño innovador se ha concebido para ofrecer una visibilidad máxima del usuario en superficie.

SIZE   TALLA	XS	S	M	L	XL	XXL	XXXL	XXXXL
HOMME   HERREN	-	1-49/S	1-49/M	1-49/L	1-49/XL	1-49/XXL	1-49/XXXL	1-49/XXXXL
DAME   DAMEN	1-50/XS	1-50/S	1-50/M	1-50/L	1-50/XL	1-50/XXL	-	-



# EMOTION

ITALIAN DESIGN



1.5 mm

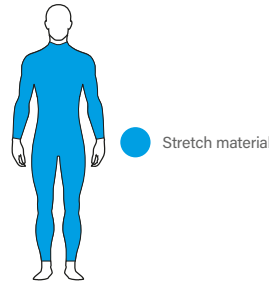
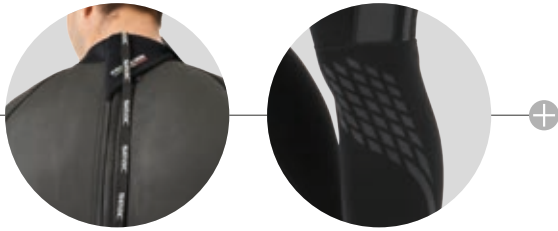

One-piece double-lined 1.5-mm neoprene suit with ample Glide Skin and Mesh Skin inserts. Flat-lock stitching. The anatomical, preformed cut and the lack of stitching around the underarms make this suit ideal for freediving and swimming in open water or the pool. Aquastop on the wrists and ankles with Smooth Skin seal. Multisport suit: freediving, snorkeling, pool and ocean swimming, surfing, etc. No stitching in the underarms. Inserts in glide-skin and mesh-skin neoprene.

Traje de una sola pieza confeccionado en una doble capa de neopreno de 1,5 mm y que incluye unas inserciones amplias en Glide Skin y Mesh Skin. Costura plana. Su corte anatómico y ergonómico, y la ausencia de costura bajo los brazos hacen que este traje resulte ideal tanto para la práctica de buceo en apnea como para nadar en aguas abiertas o en la piscina. Aquastop en las muñecas y tobillos mediante sellado en Smooth Skin. Traje apto para varios deportes: buceo en apnea, esnórquel, natación en piscina y océano, surf, etc. Sin costuras bajo los brazos. Inserciones en Glide Skin y Mesh Skin.

SIZE   TALLA	S	M	L	XL	XXL
COD.	1-38/S	1-38/M	1-38/L	1-38/XL	1-38/XXL

# HUNT VEST | VEST FLUO



New one-size backpack for weights in double-lined neoprene in black or high-visibility fluorescent orange. Ideal for spearfishing, freediving and swimming in open water. Adjustment system with 25-mm strap and buckles with a special fastening system to make it easy to unfasten quickly when needed. Main thickness: 5 mm. 6 neoprene pockets on the back for standard 1-kg weights for a total of 6 kg.

Nueva mochila de talla único para lastre, hecha de neopreno doble capa de color negro y anaranjado fluorescente. Brinda gran visibilidad y es ideal para practicar la pesca submarina, apnea y natación en aguas abiertas. Sistema de ajuste con una correa de 25 mm y hebillas con sistema de ajuste especial que facilitan la liberación rápida cuando se lo necesita. Grosor principal: 5 mm. 6 bolsillos de neopreno en la espalda para lastres estándar de 1 kg, para llegar a un total de 6 kg.

COLOR	BLACK	ORANGE
COD.	99-10N	99-11NO



### ANATOMIC



3.5 mm

5 mm

7 mm

### STANDARD HD



2.5 mm

Smooth Skin ankle and Supratex sole.

Parte superior en Smooth Skin y suela en Supratex.

SIZE   TALLA	S	M	L	XL	XXL
7 mm	0406/02	0406/03	0406/04	0406/05	0406/06
5 mm	0405/02	0405/03	0405/04	0405/05	0405/06
3.5 mm	0404/02	0404/03	0404/04	0404/05	0404/06

2.5 mm neoprene socks and Supratex sole.

Escarpín anatómico de 2,5 mm y suela en Supratex.

XS	S	M	L	XL	XXL
0403/01	0403/02	0403/03	0403/04	0403/05	0403/06

### SEAL SKIN CAMO



3 mm

3 mm, camo covering and Supratex sole.

Recubrimiento en camuflaje de 3 mm y suela Supratex.

SIZE   TALLA	S	M	L	XL	XXL
BLUE CAMO	21-9/S	21-9/M	21-9/L	21-9/XL	21-9/XXL
BROWN CAMO	21-6/S	21-6/M	21-6/L	21-6/XL	21-6/XXL
GREEN CAMO	21-8/S	21-8/M	21-8/L	21-8/XL	21-8/XXL

### TECHNICAL CHARACTERISTICS | CARACTERÍSTICAS TÉCNICAS\*

GLOVES SIZE   TALLA DE GUANTES	XS	S	M	L	XL	XL	XXL
SIZE   TALLA	6	7	8	9	10	11	12
PALM CIRCUMFERENCE - cm CIRCUNFERENCIA DE PALMA - cm	19 - 20.5	20.5 - 22	22 - 23.5	23.5 - 25	25 - 26.5	26.5 - 28	28 - 29.5
BOOTS SIZE   TALLA DE ESCARPINES	XXS	XS	S	M	L	XL	XXL
EU SIZE   TALLA EU	36 - 37	37 - 38	38 - 39	40 - 41	42 - 43	43 - 44	45 - 46
FOOT LENGTH - cm LONGITUD DEL PIE - cm	23	24	25	26	27	28	28

\* The measures are indicative and may vary depending on the model.  
\* Las medidas son indicativas y pueden variar según el modelo.

### COMFORT 3.0



NEW



3.0 mm standard nylon glove, palm in non-slip PU.

Guante de nailon estándar de 3 mm y palma en PU antideslizante.

XXS	XS	S	M	L	XL	XXL
16-12/XXS	16-12/XS	16-12/S	16-12/M	16-12/L	16-12/XL	16-12/XXL

### AMARA COMFORT



NEW



1.5 mm glove in standard nylon, amara on the palm, and Velcro closure with elastic.

Guante de 1,5 mm confeccionado en nailon estándar, amara en la palma de la mano y cierre de Velcro con tira elástica.

XS	S	M	L	XL	XXL
16-8/XS	16-8/S	16-8/M	16-8/L	16-8/XL	16-8/XXL

### ANATOMIC CAMO



	S	M	L	XL	XXL
	16-2/S	16-2/M	16-2/L	16-2/XL	16-2/XXL
	16-3/S	16-3/M	16-3/L	16-3/XL	16-3/XXL
	16-5/S	16-5/M	16-5/L	16-5/XL	16-5/XXL

### ULTRAFLEX CAMO



NEW



XS	S	M	L	XL	XXL
16-13/XS	16-13/S	16-13/M	16-13/L	16-13/XL	16-13/XXL

### ULTRAFLEX



UPGRADE



Ultraflex neoprene glove with Rubber Coated palm.

Guante de neopreno Ultraflex y palma de la mano con recubrimiento de goma.

SIZE   TALLA	XS	S	M	L	XL	XXL
ULTRAFLEX 2 MM	16-11/XS	16-11/S	16-11/M	16-11/L	16-11/XL	16-11/XXL
ULTRAFLEX 3.5 MM	16-10/XS	16-10/S	16-10/M	16-10/L	16-10/XL	16-10/XXL
ULTRAFLEX 5 MM	16-9/XS	16-9/S	16-9/M	16-9/L	16-9/XL	16-9/XXL







# Spearguns | Fusiles

SEAC® sling guns are the result of meticulous internal design, with a careful eye to the various ways they will be used, both competitively and recreationally, with options for demanding users as well as for novices trying out spearfishing for the first time. We select our materials extremely carefully, and we never stop innovating, which ensures our success on the market and wins the enormous appreciation of our users.

SEAC® offers spearfishing enthusiasts its more than thirty years of experience in manufacturing compressed air weapons. Absolute expertise and reliability are watchwords at Seac, along with Italian manufacturing tradition and quality, which set SEAC® spearguns apart. Our weapons are assembled internally and quality tested with special equipment.

Los fusiles de gomas SEAC® son el resultado de un meticuloso trabajo realizado por nuestros diseñadores internos, con una atención al detalle puesta en las diversas maneras en las que los usuarios puedan querer usarlos, ya sea tanto en el ámbito competitivo como en el recreativo, y con opciones disponibles tanto para usuarios exigentes como para principiantes que prueban la pesca submarina por primera vez.

SEAC ofrece a los entusiastas de la pesca submarina más de treinta años de experiencia en la fabricación de armas de aire comprimido. Además de su tradición en una fabricación italiana y de calidad, experiencia y fiabilidad absolutas son ambas consignas de SEAC, que es lo que confiere a sus fusiles una marca de distinción. Nuestras armas se ensamblan internamente en nuestras instalaciones y se someten a pruebas de calidad con equipamientos especiales.





# GUUN 28 | GUUN 28 KAMA

MADE IN ITALY

**EXTRA LIGHT**  
830 gr  
GUUN 28 / 85

**SHARK LASER**  
SHAFT  
Ø 6.5 MM

**REEL INCLUDED**

GUUN 28

GUUN 28 KAMA



**28**  
**MM**

INCLUDED

- Barrel: circular, with 28 mm diam. cross section. Made of extruded 6060 Series Anticorodal aluminum with lower rib. Integrated shaft guide.
- Muzzle: open, with seat for two circular slings and line fastening system to lock the shaft.
- Butt: ergonomically shaped, made in dual materials and differentiated densities. Ideal for extended use. Waterproof seal in the butt, even under extreme loads, thanks to double O-ring seated on a special independent pivoting internal drum.
- Triggering mechanism: in laser-cut stainless steel with antifriction polishing on every component.
- Sling: double circular Progressive Power Red D Dyneema with specially formulated blend and coating to ensure greater resistance to abrasion and UV rays. Diameter 14.5 mm.
- Shaft: in 17-4 PH heat-treated stainless steel, Shark type with small laser-welded fins. Diameter 6.5 mm.
- Mechanism: shifted back to ensure the longest run and most power for the shaft.
- Included standard: Guun 30 m Reel (size 75/85) or Guun 50 m Reel without line (size 95/105).
- Finish (Guun 28 Kama): special Kama camouflage treatment
- Two different handles of different sizes to adapt to any kind of hand.

- Cañón: circular, con una sección transversal de 28 mm de diámetro. Fabricado en aluminio extrudido anticorodal de la serie 6060 con un abrazadera en la parte inferior. Sistema de guía de flecha integrado.
- Cabezal: abierto, con alojamiento para dos gomas circulares y un sistema de unión de la línea para bloquear la flecha.
- Culata: ergonómica, fabricada en material doble y densidades diferenciadas. Ideal para usos prolongados. Sellado impermeable en la culata, incluso bajo condiciones de carga extremas, gracias a una doble junta tórica en un tambor especial interno oscilante e independiente.
- Mecanismo de disparo: en acero inoxidable de corte láser, con lustre anti-fricción en cada uno de los componentes.
- Goma: doble circular Progressive Power Red D Dyneema con una combinación formulada especialmente y recubrimiento que garantiza una mayor resistencia a la abrasión y a los rayos UV. Diámetro 14.5 mm.
- Flecha: tipo Shark en acero inoxidable 17-4 PH tratado térmicamente y con unas pequeñas aletas soldadas a láser. Diámetro 6,5 mm.
- Mecanismo: desplazado para garantizar un recorrido más largo y mayor potencia en la flecha.
- Estándar incluido: carrete Guun 30 (tamaño 75/85) o carrete Guun 50 sin línea (tamaño 95/105).
- Dos asas de distintos tamaños para adaptarse a cualquier tipo de mano.
- Tratamiento especial Kama de camuflaje (Guun 28 Kama)

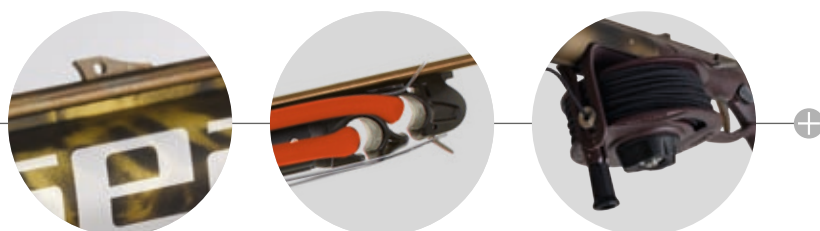

Includes:  
Shark Laser Shaft with single upper barb (ø x cm)  
Power Red Dyneema circular sling (ø x cm)

Include:  
Flecha Shark Laser con rebaba en la parte superior (ø x cm)  
Goma circular Power Red Dyneema (ø x cm)

LENGTH   LONGITUD	75 cm	85 cm	95 cm	105 cm	115 cm	SHAFT   FLECHA	SLINGS   GOMAS
GUUN 28	121-27/75	121-27/85	121-27/95	121-27/105	121-27/115	75	132-11/6,5X115
GUUN 28 KAMA	121-26/75	121-26/85	121-26/95	121-26/105	-	85	132-11/6,5X130
REEL   CARRETE	30 m	30 m	50 m	50 m	50 m	95	132-11/6,5X140
						105	132-11/6,5X150
						115	132-11/6,5X165
							127-29/14.5X48
							127-29/14.5X54
							127-29/14.5X60
							127-29/14.5X64
							127-29/14.5X72



# GUUN 28 NAKED

MADE IN ITALY



- Barrel: circular, with 28 mm diam. cross section. Made of extruded 6060 Series Anticorodal aluminum with lower rib. Integrated shaft guide.
- Muzzle: open, with seat for two circular slings and line fastening system to lock the shaft.
- Triggering mechanism: in laser-cut stainless steel with antifriction polishing on every component.
- Mechanism: shifted back to ensure the longest run and most power for the shaft.
- Cañón: circular, con una sección transversal de 28 mm de diámetro. Fabricado en aluminio extrudido anticorodal de la serie 6060 con un abrazadera en la parte inferior. Sistema de guía de flecha integrado.
- Cabezal: abierto, con alojamiento para dos gomas circulares y un sistema de unión de la línea para bloquear la flecha.
- Mecanismo de disparo: en acero inoxidable de corte láser, con lustre anti-fricción en cada uno de los componentes.
- Mecanismo: desplazado para garantizar un recorrido más largo y mayor potencia en la flecha.

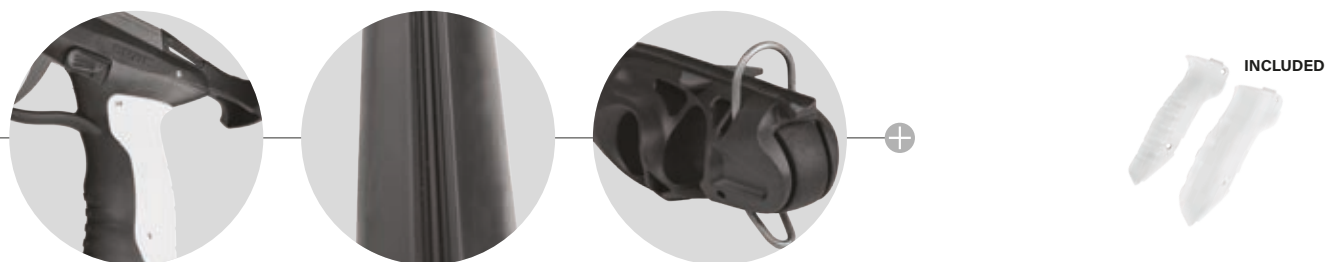

LENGTH   LONGITUD	75 cm	85 cm	95 cm	105 cm	115 cm
GUUN 28 NAKED	121-40/75	121-40/85	121-40/95	121-40/105	121-40/115

# CONDOR

MADE IN ITALY



- Barrel: circular, with 28 mm diam. cross section. Made of extruded 6060 Series Anticorodal aluminum with lower rib. Integrated shaft guide.
- Muzzle: version for using parallel slings.
- Triggering mechanism: in laser-cut stainless steel with antifriction polishing on every component.
- Trigger: in special high-strength technopolymer.
- Cañón: circular, con una sección transversal de 28 mm de diámetro. Fabricado en aluminio extrudido anticorodal de la serie 6060 con un abrazadera en la parte inferior. Sistema de guía de flecha integrado.
- Cabezal: versión para usar gomas paralelas.
- Mecanismo de disparo: en acero inoxidable de corte láser, con lustre anti-fricción en cada uno de los componentes.
- Gatillo: en tecnopolímero especial de gran resistencia.

Includes:  
Inox 17-4PH with single upper barb (ø x cm)  
Dual Power Red slings (ø x cm)

Incluye:  
Flecha Inox 17-4PH con rebaba en la parte superior (ø x cm)  
Par de gomas Power Red (ø x cm)

LENGTH   LONGITUD	50 cm	60 cm	75 cm
COD.	121-31/50	121-31/60	121-31/75
LOADING PAD APOYO DE CARGA	MINI	MINI	STANDARD

LENGTH   LONGITUD	85 cm	95 cm	105 cm
COD.	121-31/85	121-31/95	121-31/105
LOADING PAD APOYO DE CARGA	STANDARD	STANDARD	STANDARD

SHAFT   FLECHA	SLINGS   GOMAS
50	132-4/6,25X85
60	132-4/6,25X95
75	132-4/6,25X115
85	132-4/6,25X130
95	132-4/6,25X140
105	132-4/6,25X150

freediving | 2020

# BLUE GUN - RED GUN

MADE IN ITALY

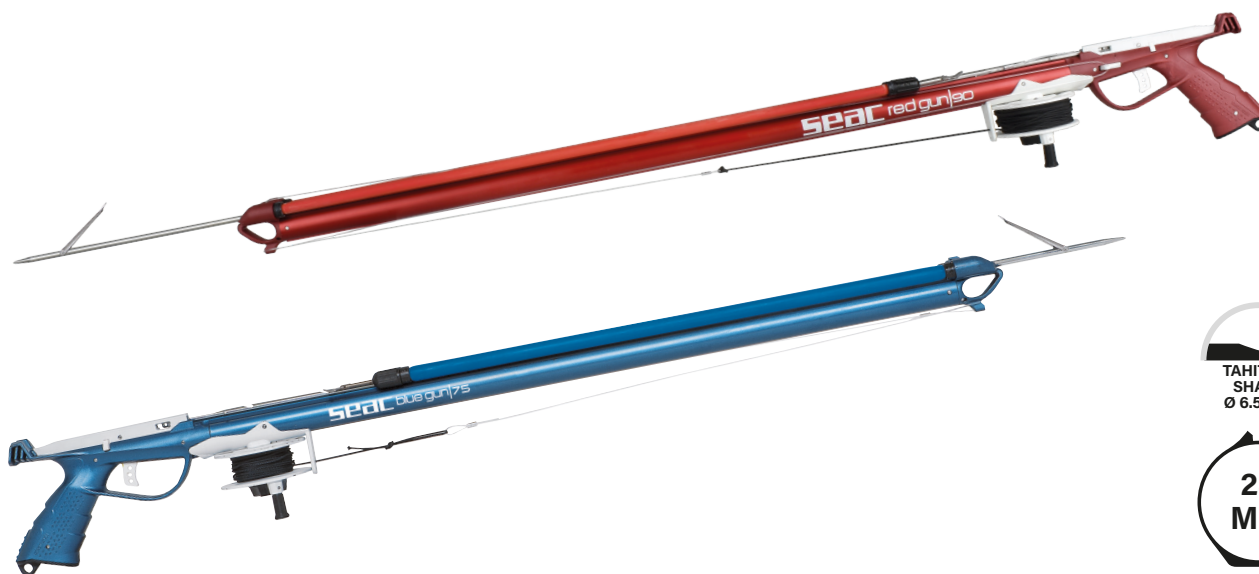

- Barrel: made of extruded 6060 Series Anticorodal aluminum. Integrated shaft guide along the full length of the barrel.
- Firing mechanism: stainless steel.
- Shaft: Tahitian, in 6.5 mm stainless steel.
- Sling (Blue Gun): pair of Power Red slings, 16 mm diameter with articulated wishbone.
- Sling (Red gun): pair of Power Blue slings, 16 mm diameter with articulated wishbone.
- Optional: reel for sling guns.

- Cañón: fabricado en aluminio extrudido anticorodal de la serie 6060. Guía para flecha integrada en todo el largo del cañón.
- Mecanismo de disparo: acero inoxidable.
- Flecha: Tahitiana, en acero inoxidable de 6,5 mm.
- Goma (Blue Gun): un par de gomas Power Blue, de 16 mm de diámetro con obús articulado.
- Goma (Red gun): un par de gomas Power Red, de 16 mm de diámetro con obús articulado.
- Opcional: carrete para fusiles de gomas.



BLUE GUN Includes:  
AISI 303 Shaft with single upper barb (ø x cm)  
Dual Power Blue slings (ø x cm)

BLUE GUN Incluye:  
Flecha AISI 303 con rebaba en la parte superior (ø x cm)  
Par de gomas Power Blue (ø x cm)

	SHAFT   FLECHA	SLINGS   GOMAS
60	132-23/6,5X90	127-31/16X16
75	132-23/6,5X105	127-31/16X18
90	132-23/6,5X120	127-31/16X22
100	132-23/6,5X130	127-31/16X24
110	132-23/6,5X140	127-31/16X26

RED GUN Includes:  
AISI 303 Shaft with single upper barb (ø x cm)  
Dual Power Red slings (ø x cm)

RED GUN Incluye:  
Flecha AISI 303 con rebaba en la parte superior (ø x cm)  
Par de gomas Power Red (ø x cm)

	SHAFT   FLECHA	SLINGS   GOMAS
60	132-23/6,5X90	127-30/16X16
75	132-23/6,5X105	127-30/16X18
90	132-23/6,5X120	127-30/16X22
100	132-23/6,5X130	127-30/16X24
110	132-23/6,5X140	127-30/16X26

LENGTH   LONGITUD	60 cm	75 cm	90 cm
BLUE GUN	121-37/60	121-37/75	121-37/90
RED GUN	121-39/60	121-39/75	121-39/90

LENGTH   LONGITUD	100 cm	110 cm	OPTIONAL REEL CARRETE OPTIONAL
BLUE GUN	121-37/100	121-37/110	COD. 1250277
RED GUN	121-39/100	121-39/110	

# KILLER

MADE IN ITALY

- Barrel: black, made in extruded Anticorodal aluminum to maximize durability and prevent bending.
- Triggering mechanism: in stainless steel and reinforced polyamide to ensure extreme functionality and reliability. Trigger, line-releaser, and safety in shockproof, high-performance nylon.
- Shaft : Tahitian, in 6,5 mm stainless steel.
- Sling: pair of black X-Powerfull slings, 16 mm diameter, with wishbone 4 mm inox.
- Handle: white for good visibility when retrieving the weapon.

- Cañón: negro, hecho en aluminio extrudido anticorodal para maximizar la durabilidad y evitar que se doble.
- Mecanismo de disparo: en acero inoxidable y poliamida reforzada para garantizar una funcionalidad y una confiabilidad extremas. Gatillo, sistema de liberación de línea y seguridad en nailon de alto rendimiento resistente a los impactos.
- Flecha: Tahitiana, en acero inoxidable de 6,5 mm.
- Goma: un par de gomas Powerfull, de 16 mm de diámetro con obús de acero inoxidable de 4 mm.
- Empuñadura: blanca para una buena visibilidad en el momento de recuperar el arma.



TAHITIAN  
SHAFT  
Ø 6.5 MM

28  
MM

Includes:  
AISI 303 shaft with single upper barb (ø x cm)  
Dual X-Power Black slings (ø x cm)

Incluye:  
Flecha AISI 303 con rebaba en la parte superior (ø x cm)  
Par de gomas X-Power Black (ø x cm)

LENGTH   LONGITUD	50 cm	60 cm
COD.	121-38/50	121-38/60

LENGTH   LONGITUD	75 cm	90 cm	100 cm
COD.	121-38/75	121-38/90	121-38/100

SHAFT   FLECHA	SLINGS   GOMAS
50 132-23/6,5X80	127-20/16X14
60 132-23/6,5X90	127-20/16X16
75 132-23/6,5X105	127-20/16X20
90 132-23/6,5X120	127-20/16X22
100 132-23/6,5X130	127-20/16X24

# STING

MADE IN ITALY

- Barrel: in extruded Anticorodal aluminum to maximize durability and prevent bending.
- Muzzle: for parallel slings.
- Butt: new anatomical handle and chest pad.
- Triggering mechanism: in stainless steel and reinforced polyamide to ensure functionality and reliability. Trigger, line-releaser, and safety in shockproof, high-performance nylon.
- Sling: Latex pair, diameter 16 mm.
- Shaft: PR80 in treated steel. Diameter 7 mm. M7 threading. Line fastening system directly on the shaft, as in professional models.
- Included: line in nylon/polyester and harpoon with M7 threading.

- Cañón: negro, hecho en aluminio extrudido anticorodal para maximizar la durabilidad y evitar que se doble.
- Cabezal: para gomas en paralelo.
- Culata: nueva empuñadura anatómica y almohadilla para el pecho.
- Mecanismo de disparo: en acero inoxidable y poliamida reforzada para garantizar una funcionalidad y una confiabilidad extremas. Gatillo, sistema de liberación de línea y seguridad en nailon de alto rendimiento resistente a los impactos.
- Goma: un par de gomas de látex de 16 mm diámetro.
- Flecha: PR80 en acero tratado. Diámetro de 7 mm. Roscado M7. Sistema de sujeción de línea directamente en la flecha, al igual que en los modelos profesionales.
- Incluye: línea de nailon/poliéster y arpón con rosca M7.



PR 80  
SHAFT  
Ø 7.0 MM

28  
MM

Includes:  
PR 80 threaded shaft (ø x cm)  
Dual Amber Latex (ø x cm)

Incluye:  
Flecha roscada PR 80 (ø x cm)  
Par de gomas Amber Latex (ø x cm)

LENGTH   LONGITUD	35 cm	45 cm	55 cm
COD.	3180/35	3180/45	3180/55

LENGTH   LONGITUD	65 cm	75 cm	85 cm
COD.	3180/65	3180/75	3180/85



SHAFT   FLECHA	SLINGS   GOMAS
35 132-9/7,0X50	127-22/16X12
45 132-9/7,0X60	127-22/16X14
55 132-9/7,0X70	127-22/16X16
65 132-9/7,0X85	127-22/16X18
75 132-9/7,0X95	127-22/16X20
85 132-9/7,0X105	127-22/16X22



## GUUN REEL | CARRETE

 MADE IN ITALY

- Double version reel with capacity of 50 or 30 m of 1.5 mm line.
- Double version featuring an automatic and independent internal anti-tangle tensioning system.
  - Sliding spooling guide in wear-resistant stainless steel.
  - Retractable arm.
  - Quick tensioning system can be engaged with 1/3 turn.
  - Reels for Guun and Condor series guns.
- Versión de carrete doble con capacidad de 50 o 30 m de línea de 1,5 mm.
- Versión doble que incorpora un sistema tensor interno automático e independiente para evitar los enredos.
  - Guiado de bobina deslizante fabricado en acero inoxidable resistente al desgaste.
  - Brazo retráctil.
  - Sistema de tensado rápido que permite rotaciones de 1/3.
  - Carretes para los fusiles de las series Guun y Condor.

MÈTRES   METER		30	50
	BLACK	1250238	1250240
	BROWN	1250239	1250241
	WHITE	125-290	-



## REEL FOR SLING GUNS CARRETE PARA FUSIL DE GOMAS

 MADE IN ITALY

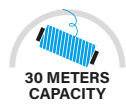

Gun reel compatible with: Blue Gun, Red Gun, Thunder, X-Fire, Ocean, Combat, Ghost, Bolt.

Carrete del fusil compatible con: Blue Gun, Red Gun, Thunder, X-Fire, Ocean, Combat, Ghost, Bolt.

COLOR	 BLACK	 WHITE
COD.	1250275	1250277

## FLOAT | FLOTANTE

 MADE IN ITALY



DIAMETER   DIÁMETRO	28 mm	30 mm
COD.	1190178	1190179



## LOADING PAD APOYO DE CARGA

 MADE IN ITALY



Cushioned loading pad. Two sizes: standard and mini.

Almohadilla de carga acolchada. Dos tamaños: estándar y mini.

SIZE   TALLA	MINI	STANDARD
	BROWN 1250209	1250208
	BLACK 1250207	1250206





## HANDLE COVER CUBIERTA DE MANGO

 MADE IN ITALY



Ergonomic handle in flexible material. Also available in maxi size for larger hands.

Empuñadura ergonómica fabricada en un material flexible.

SIZE   TALLA	STANDARD	MAXI
	WHITE 1250203	1250264
	YELLOW 1250204	1250266
	GREEN 1250205	1250268
	RED 1250249	1250267
	BLUE 1250263	1250265

### X-FIRE MUZZLE | CABEZAL X-FIRE

MADE IN ITALY



Open type with seat for two circular slings, no upper bridge, with line fastening system to lock the shaft. Suitable for barrels with 28 mm external diameter (internal 26 mm).

De tipo abierto con alojamiento para dos gomas circulares, sin puente en la parte superior y sistema de unión de línea para bloquear la flecha. Apto para cañones con un diámetro externo de 28 mm (e interno de 26 mm).

COD. 1250243

### DOUBLE MUZZLE | DOBLE CABEZAL

MADE IN ITALY



Hybrid style that lets you switch easily between dual slings and circular slings. Suitable for barrels with 28 mm external diameter (internal 26 mm).

Estilo híbrido que le permite cambiar fácilmente entre gomas dobles y circulares. Apto para cañones con un diámetro externo de 28 mm (e interno de 26 mm).

	BROWN	1250244
	BLACK	312001

### GUUN 28 MUZZLE | CABEZAL GUUN 28

MADE IN ITALY



Quick-loading open type with seat for two circular slings and line fastening system to lock the shaft. Removable stainless steel bridge. Suitable for barrels with 28 mm external diameter (internal 26 mm).

Tipo abierto para carga rápida con alojamiento para dos gomas circulares y un sistema de unión de la línea para bloquear la flecha. Puente de acero inoxidable extraíble. Apto para cañones con un diámetro externo de 28 mm (e interno de 26 mm).

	BROWN	1250248
	BLACK	1250246

### X-FIRE MUZZLE ONE SLING CABEZAL X-FIRE, UNA GOMA

MADE IN ITALY



Open type with seat for one circular sling, no upper bridge, with line fastening system to lock the shaft. Suitable for barrels with 28 mm external diameter (internal 26 mm).

De tipo abierto con alojamiento para una goma circular, sin puente en la parte superior y con un sistema de unión de línea para bloquear la flecha. Apto para cañones con un diámetro externo de 28 mm (e interno de 26 mm).

COD. 1250242

### CLOSED MUZZLE CABEZAL CERRADO

MADE IN ITALY



Closed top for using parallel slings. Suitable for barrels with 28 mm external diameter (internal 26 mm).

Parte superior cerrada para usar gomas paralelas. Apto para cañones con un diámetro externo de 28 mm (e interno de 26 mm).

	BROWN	S270011
	BLACK	S317001
	BLUE	1250280
	RED	125-2

# TECHNICAL CHARACTERISTICS | CARACTERÍSTICAS TÉCNICAS

SLINGS GOMAS	ANTHRACITE FLEX			PROGRESSIVE POWER RED			PROGRESSIVE POWER BLUE			X-POWERFULL				LATEX AMBRA		
DIAMETER (mm) DIÁMETRO (mm)	14.5	16	17.5	14.5	16	17.5	14.5	16	17.5	14.5	16	17.5	19.5	16	17.5	19.5
OPTIMAL ELONGATION ELONGACIÓN ÓPTIMA	3.5	3.5	3.5	3.4	3.4	3.4	3.3	3.3	3.3	3.3	3.3	3.3	3.3	3.2	3.2	3.2
ELONGATION FORCE FUERZA DE ELONGACIÓN (300%)	300	390	480	360	450	550	320	420	530	310	405	520	600	400	510	580



## ANTHRACITE FLEX



5 meter package of coextruded sling.

Un paquete de 5 metros de goma Progressive Powered Red coextruída.

Ø 14.5 mm	127-7/14,5X500
Ø 16 mm	127-7/16X500
Ø 17.5 mm	127-7/17,5X500



## PROGRESSIVE POWER RED



5 meter package of coextruded sling.

Un paquete de 5 metros de goma Progressive Powered Red coextruída.

Ø 14.5 mm	127-4/14,5X500
Ø 16 mm	127-4/16X500
Ø 17.5 mm	127-4/17,5X500



## PROGRESSIVE POWER BLUE



5 meter package of coextruded sling.

Un paquete de 5 metros de goma Progressive Powered Blue coextruída.

Ø 14.5 mm	127-6/14,5X500
Ø 16 mm	127-6/16X500
Ø 17.5 mm	127-6/17,5X500



## X-POWERFULL



5 meter package of sling.

Paquete de 5 metros de goma X-Powerfull.

Ø 14.5 mm	127-2/14,5X500
Ø 16 mm	127-2/16X500
Ø 17.5 mm	127-2/17,5X500
Ø 19.5 mm	127-2/19,5X500



## LATEX



5 meters package of natural latex sling.

Paquete de 5 metros de goma Amber Latex.

Ø 16 mm	127-1/16X500
Ø 17 mm	127-1/17,5X500
Ø 19.5 mm	127-1/19,5X500





## POWER RED D

MADE IN ITALY

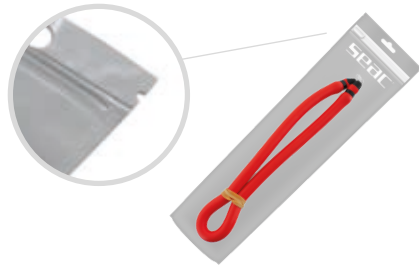

LENGTH   LONGITUD	48 cm	54 cm	60 cm	64 cm	72 cm	
COD. (Ø 14.5 mm)	127-29/14,5X48	127-29/14,5X54	127-29/14,5X60	127-29/14,5X64	127-29/14,5X72	
LENGTH   LONGITUD	48 cm	56 cm	64 cm	72 cm	80 cm	90 cm
COD. (Ø 16 mm)	127-29/16X48	127-29/16X56	127-29/16X64	127-29/16X72	127-29/16X80	127-29/16X90

## POWER BLUE D

MADE IN ITALY

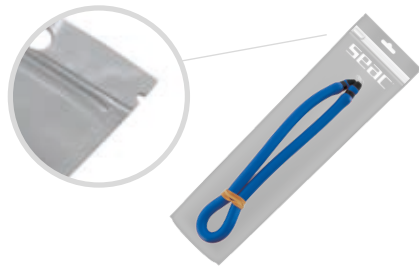

LENGTH   LONGITUD	48 cm	50 cm	54 cm	56 cm	60 cm	62 cm
COD. (Ø 16 mm)	127-32/16X48	127-32/16X50	127-32/16X54	127-32/16X56	127-32/16X60	127-32/16X62
LENGTH   LONGITUD	64 cm	66 cm	72 cm	80 cm	90 cm	
COD. (Ø 16 mm)	127-32/16X64	127-32/16X66	127-32/16X72	127-32/16X80	127-32/16X90	

## X-POWERFULL CIRCULAR

MADE IN ITALY

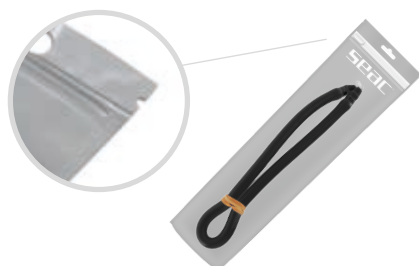

LENGTH   LONGITUD	36 cm	38 cm	40 cm	46 cm	48 cm	50 cm		
COD. (Ø 17.5 mm)	127-21/17,5X36	127-21/17,5X38	127-21/17,5X40	127-21/17,5X46	127-21/17,5X48	127-21/17,5X50		
LENGTH   LONGITUD	54 cm	56 cm	58 cm	62 cm	66 cm	70 cm		
COD. (Ø 17.5 mm)	127-21/17,5X54	127-21/17,5X56	127-21/17,5X58	127-21/17,5X62	127-21/17,5X66	127-21/17,5X70		
LENGTH   LONGITUD	46 cm	50 cm	52 cm	56 cm	60 cm	64 cm	68 cm	72 cm
COD. (Ø 19.5 mm)	127-21/19,5X46	127-21/19,5X50	127-21/19,5X52	127-21/19,5X56	127-21/19,5X60	127-21/19,5X64	127-21/19,5X68	127-21/19,5X72

## DUAL POWER RED PAR DE POWER RED

MADE IN ITALY



LENGTH   LONGITUD	16 cm	18 cm	20 cm	22 cm
-------------------	-------	-------	-------	-------

Ø 16 mm	127-30/16X16	127-30/16X18	127-30/16X20	127-30/16X22
---------	--------------	--------------	--------------	--------------

LENGTH   LONGITUD	24 cm	26 cm	28 cm	30 cm
-------------------	-------	-------	-------	-------

Ø 16 mm	127-30/16X24	127-30/16X26	127-30/16X28	127-30/16X30
---------	--------------	--------------	--------------	--------------

LENGTH   LONGITUD	18 cm	20 cm	22 cm	24 cm	26 cm	28 cm	30 cm
-------------------	-------	-------	-------	-------	-------	-------	-------

Ø 17.5 mm	127-30/17,5X18	127-30/17,5X20	127-30/17,5X22	127-30/17,5X24	127-30/17,5X26	127-30/17,5X28	127-30/17,5X30
-----------	----------------	----------------	----------------	----------------	----------------	----------------	----------------

## DUAL POWER BLUE PAR DE POWER BLUE

MADE IN ITALY

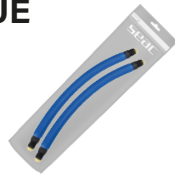

LENGTH   LONGITUD	16 cm	19 cm	22 cm	24 cm	26 cm
-------------------	-------	-------	-------	-------	-------

COD. (Ø 17.5 mm)	127-31/17,5X16	127-31/17,5X19	127-31/17,5X22	127-31/17,5X24	127-31/17,5X26
------------------	----------------	----------------	----------------	----------------	----------------

LENGTH   LONGITUD	16 cm	18 cm	22 cm	24 cm	26 cm	28 cm	30 cm
-------------------	-------	-------	-------	-------	-------	-------	-------

COD. (Ø 16 mm)	127-31/16X16	127-31/16X18	127-31/16X22	127-31/16X24	127-31/16X26	127-31/16X28	127-31/16X30
----------------	--------------	--------------	--------------	--------------	--------------	--------------	--------------

## DUAL LATEX AMBRÉ PAR DE AMBER LATEX

MADE IN ITALY

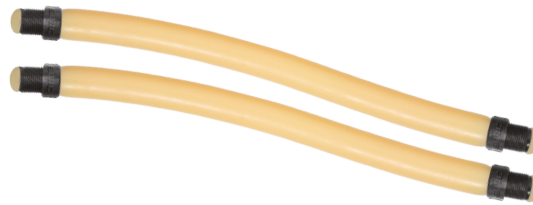

LENGTH   LONGITUD	12 cm	14 cm	16 cm	18 cm	20 cm	22 cm
-------------------	-------	-------	-------	-------	-------	-------

COD. (Ø 16 mm)	127-22/16X12	127-22/16X14	127-22/16X16	127-22/16X18	127-22/16X20	127-22/16X22
----------------	--------------	--------------	--------------	--------------	--------------	--------------

LENGTH   LONGITUD	24 cm	26 cm	28 cm	30 cm	32 cm	36 cm
-------------------	-------	-------	-------	-------	-------	-------

COD. (Ø 16 mm)	127-22/16X24	127-22/16X26	127-22/16X28	127-22/16X30	127-22/16X32	127-22/16X36
----------------	--------------	--------------	--------------	--------------	--------------	--------------

## DUAL X-POWERFULL PAR DE X-POWERFULL

MADE IN ITALY



LENGTH   LONGITUD	14 cm	16 cm	18 cm	20 cm	22 cm	24 cm	26 cm	28 cm	30 cm
-------------------	-------	-------	-------	-------	-------	-------	-------	-------	-------

Ø 16 mm	127-20/16X14	127-20/16X16	127-20/16X18	127-20/16X20	127-20/16X22	127-20/16X24	127-20/16X26	127-20/16X28	127-20/16X30
---------	--------------	--------------	--------------	--------------	--------------	--------------	--------------	--------------	--------------

LENGTH   LONGITUD	16 cm	18 cm	19 cm	20 cm	22 cm
-------------------	-------	-------	-------	-------	-------

Ø 17.5 mm	127-20/17,5X16	127-20/17,5X18	127-20/17,5X19	127-20/17,5X20	127-20/17,5X22
-----------	----------------	----------------	----------------	----------------	----------------

LENGTH   LONGITUD	24 cm	26 cm	28 cm	30 cm	32 cm
-------------------	-------	-------	-------	-------	-------

Ø 17.5 mm	127-20/17,5X24	127-20/17,5X26	127-20/17,5X28	127-20/17,5X30	127-20/17,5X32
-----------	----------------	----------------	----------------	----------------	----------------

LENGTH   LONGITUD	18 cm	20 cm	22 cm	24 cm	26 cm	28 cm	30 cm	32 cm
-------------------	-------	-------	-------	-------	-------	-------	-------	-------

Ø 19.5 mm	127-20/19,5X18	127-20/19,5X20	127-20/19,5X22	127-20/19,5X24	127-20/19,5X26	127-20/19,5X28	127-20/19,5X30	127-20/19,5X32
-----------	----------------	----------------	----------------	----------------	----------------	----------------	----------------	----------------

## STANDARD WISHBONE OBÚS ESTÁNDAR

 **MADE IN ITALY**

Standard wishbone.

Obús estándar.



COD. 089

## ARTICULATED WISHBONE OBÚS ARTICULADO

 **MADE IN ITALY**

Universal articulated wishbone.

Obús articulado universal.



COD. 3585

## WISHBONE Ø 4 mm OBÚS Ø 4 mm

 **MADE IN ITALY**

Simple flattened wishbone in 304 stainless steel, line ø 4 mm assembled with brass bushings.

Obús plano sencillo en acero inoxidable 304, diámetro de la línea de 4 mm montada con cojinetes de latón.



COD. 270501

## WISHBONE BUSHINGS Ø 4 mm COJINETES DE 4 MM DE DIÁMETRO

 **MADE IN ITALY**

Simple flattened wishbone in 304 stainless steel, line ø 4 mm.

Obús plano sencillo en acero inoxidable 304, diámetro de la línea de 4 mm.



COD. 1250199

## WISHBONE Ø 3 mm OBÚS Ø 3 mm

 **MADE IN ITALY**

Simple flattened wishbone in 304 stainless steel, line ø 3 mm, small radius.

Obús plano sencillo en acero inoxidable 304, diámetro de la línea de 3 mm, radio pequeño.



COD. 270502

## OMEGA WISHBONE OBÚS OMEGA

 **MADE IN ITALY**

Wishbone with puller and washer.

Obús con tirador y arandela.



COD. 270504

## OMEGA WISHBONE M5 OBÚS OMEGA M5

 **MADE IN ITALY**

Wishbone with M5 threaded puller.

Obús con tirador roscado M5.



COD. 270503

## HEAD CONNECTOR PIN KIT KIT DE CLAVIJAS PARA CONECTAR CABEZALES

 **MADE IN ITALY**

Sling connector bushing kit and pins.

Kit de bujes y clavijas para conectar las gomas.



COD. 3577



# CACCIA HF

MADE IN ITALY



- Outer barrel: aluminum alloy cylinder with a hydrodynamic shape achieved using Hydroforming technology. This makes it possible to increase the capacity of the outer barrel to make it easier to aim horizontally and to improve trim and buoyancy. The area near the handle is cylindrical so that a reel (optional) can be mounted.
  - Muzzle: the end narrows to make the shaft easier to see, thereby improving the line of sight.
  - Handle: with ergonomic computer design. Made in two soft overmoulded materials to improve comfort and grip.
  - Barrel: with a narrower diameter of 11.2 mm, it reduces the amount of water the weapon has to expel, decreasing loading force and delivering a significant increase in shaft exit speed.
  - Characteristics: the reduced size of the piston that acts on the trigger mechanism allows for excellent sensitivity and lower firing force.
  - Included: stainless steel shaft, 7 mm in diameter, injector, harpoon, harpoon loader, line, and carrying bag.
- Cañón exterior: cilindro fabricado a partir de una aleación de aluminio y con una forma hidrodinámica que se ha obtenido mediante la aplicación de la tecnología de hidroconformado. Esto permite aumentar la capacidad del cañón exterior y hace que sea más fácil apuntar en una posición horizontal, mejorando el trimado y la flotación. El área que está cerca de la empuñadura es cilíndrica, de modo que se pueda montar un Carrete (opcional).
  - Cabezal: el extremo final se hace más angosto para que la flecha sea más fácil de ver, lo cual mejora la línea de visión.
  - Empuñadura: con diseño ergonómico computarizado. Fabricada en dos materiales suaves sobremoldeados para una mayor comodidad y agarre.
  - Cañón: con un diámetro más angosto de 11,2 mm que reduce la cantidad de agua que debe expulsar el arma, lo cual reduce la fuerza de carga y brinda un considerable aumento en la velocidad de salida de la flecha.
  - Características: el tamaño reducido del pistón que actúa sobre el mecanismo de disparo, permite lograr una sensibilidad excelente y una menor fuerza de disparo.
  - Incluye: flecha de acero inoxidable, de 7 mm de diámetro, inyector, arpón, cargador de arpón, línea y bolsa de transporte.

freediving|2020

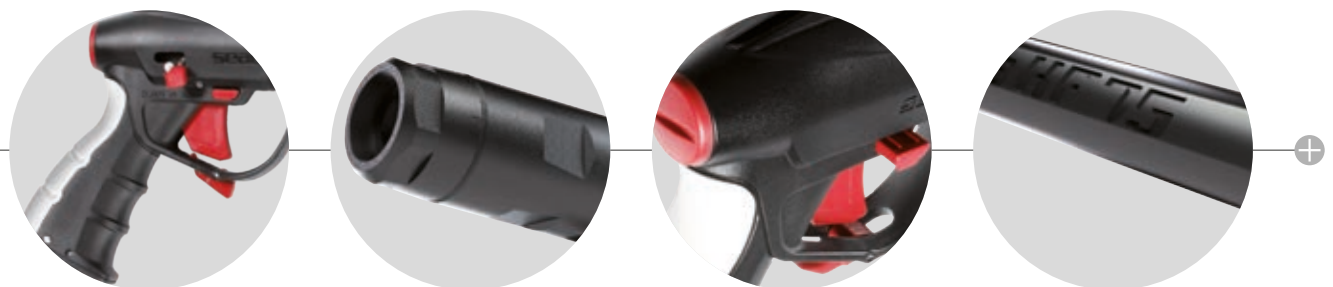

LENGTH   LONGITUD	75 cm	90 cm	115 cm
COD.	457	458	459
SHAFT   FLECHA	77.3 cm	87.3 cm	113.3 cm

# ASSO C/R - ASSO S/R

MADE IN ITALY

13  
MM

ASSO C/R  
with power regulation  
con regulación de potencia



ASSO S/R  
without power regulation  
sin regulación de potencia



- Outer barrel: aluminum alloy cylinder, diameter 40 mm.
- Muzzle: in light alloy with larger holes to optimize water drainage.
- Handle: ergonomic and functional.
- Barrel: 13 mm in diameter, making it possible to use 8 mm shafts.
- Characteristics: regulator that makes it possible to reduce the weapon's power by half when needed (Asso C/R), Wide range of sizes.
- Included: steel shaft, injector, harpoon, harpoon loader, line, carrying bag (Asso C/R).
- Optional (Asso S/R): Asso 30 holster.

- Cañón exterior: cilindro de aleación de aluminio, 40 mm de diámetro.
- Cabezal: fabricado en una aleación ligera con orificios más grandes para un mejor secado.
- Empuñadura: ergonómica y funcional.
- Cañón: 13 mm de diámetro, lo que permite usar flechas de 8 mm .
- Características: regulador que permite reducir la potencia del arma a la mitad siempre que se necesite. Amplio intervalo de tamaños, desde 50 cm a 135 cm.
- Incluye: flecha de acero, inyector, arpón, cargador de arpón, línea y bolsa de transporte.

ASSO C/R	50 cm	65 cm	75 cm	90 cm	115 cm	135 cm
COD.	605	606	607	608	609	615
SHAFT   FLECHA	52.3 cm	67.3 cm	77.3 cm	87.3 cm	113.3 cm	132.3 cm
ASSO S/R	30 cm	40 cm	50 cm	65 cm	75 cm	
COD.	600	601	602	603	604	
SHAFT   FLECHA	24.3 cm	37.3 cm	52.3 cm	67.3 cm	77.3 cm	

## ASSO 30 HOLSTER FUNDA ASSO 30

 **MADE IN ITALY**



Holster for ASSO 30 pneumatic gun.

Funda ASSO 30 para fusil neumático.

COD. 611

## PNEUMATIC GUN REEL BOBINA PARA FUSIL NEUMÁTICO

 **MADE IN ITALY**



Reel for pneumatic spearguns.

Carrete para fusiles neumáticos.

COD. 100

## PNEUMATIC GUN OIL ACEITE PARA FUSIL NEUMÁTICO

 **MADE IN ITALY**



Oil for compressed-air guns, 100 ml.

Aceite para fusiles de aire comprimido, 100 ml.

COD. 60600

## SHARK LASER SHAFT | FLECHA SHARK LASER

 **MADE IN ITALY**



Heated-treated 17-4 PH stainless steel,  
Shark style with laser-welded fins and single upper barb.  
Diameter: 6.5/7 mm.

Modelo Shark, fabricado en acero inoxidable 17-4 PH tratado térmicamente;  
incluye unas aletas y una rebaba en la parte superior soldadas a láser.  
Diámetro: 6,5-7 mm.

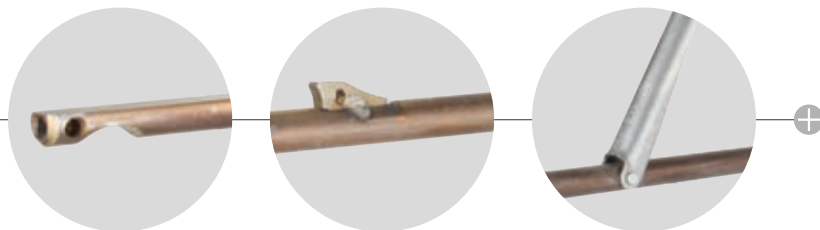
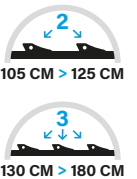

LENGTH   LONGITUD	105 cm	115 cm	120 cm	125 cm	130 cm
COD. (Ø 6.5 mm)	132-11/6,5X105	132-11/6,5X115	132-11/6,5X120	132-11/6,5X125	132-11/6,5X130
COD. (Ø 7.0 mm)	132-11/7X105	132-11/7X115	132-11/7X120	132-11/7X125	132-11/7X130

LENGTH   LONGITUD	135 cm	140 cm	145 cm	150 cm	165 cm	180 cm
COD. (Ø 6.5 mm)	132-11/6,5X135	132-11/6,5X140	132-11/6,5X145	132-11/6,5X150	132-11/6,5X165	-
COD. (Ø 7.0 mm)	132-11/7X135	132-11/7X140	132-11/7X145	132-11/7X150	132-11/7X165	132-11/7X180



## INOX 17-4 PH TAHITIAN | INOX 17-4 PH TAHITIANA

MADE IN ITALY



Tahitian shaft, 17-4 PH stainless steel with single upper barb.

- Tensile strength: 1300N/mm<sup>2</sup>.
- Hardness: 45 Hrc.
- Barb: 7.4 cm.
- Diameter: 6.25 mm.

Flecha tahitiana de acero inoxidable 17-4 PH con una rebaba única situada en la parte superior.

- Fuerza de tensión: 1300N/mm<sup>2</sup>.
- Dureza: 45 HRC.
- Rebaba: 7,4 cm.
- Diámetro: 6,25 mm.

COD.	132-4/6,25X85	132-4/6,25X95	132-4/6,25X105	132-4/6,25X115	132-4/6,25X120
LENGTH   LONGITUD	85 cm	95 cm	105 cm	115 cm	120 cm

COD.	132-4/6,25X125	132-4/6,25X130	132-4/6,25X135	132-4/6,25X140	132-4/6,25X145	132-4/6,25X150
LENGTH   LONGITUD	125 cm	130 cm	135 cm	140 cm	145 cm	150 cm

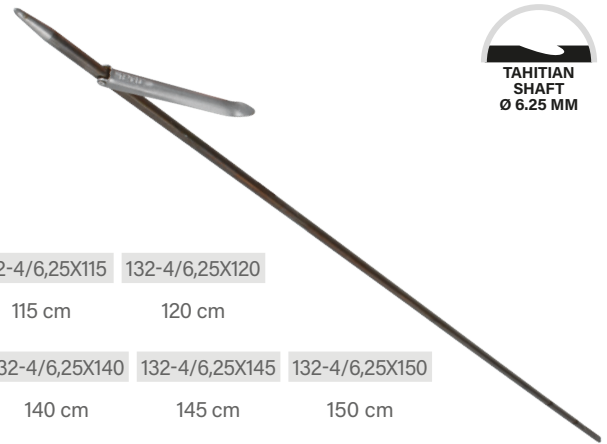

## 17-4PH ROUND | 17-4PH REDONDA



Round Tahitian shaft, 17-4 PH stainless steel with single upper barb.  
Diameter: 6.25 and 6.50 mm.

Flecha tahitiana redonda de acero inoxidable 17-4 PH con monoaleta superior.  
Diámetro: 6,25 y 6,50 mm.

REPLACEMENT BARB | ALETA DE RECAMBIO  
COD. S311126

LENGTH LONGITUD	105 cm	115 cm	120 cm	125 cm	130 cm	135 cm	140 cm	145 cm
6.25 mm	132-13/6,25X105	132-13/6,25X115	132-13/6,25X120	132-13/6,25X125	132-13/6,25X130	132-13/6,25X135	132-13/6,25X140	-
6.50 mm	132-13/6,5X105	132-13/6,5X115	132-13/6,5X120	132-13/6,5X125	132-13/6,5X130	132-13/6,5X135	132-13/6,5X140	132-13/6,5X145



## INOX

MADE IN ITALY



Tahitian shaft, stainless steel, with single upper barb.

- Tensile strength: 750N/mm<sup>2</sup>.
- Barb: 7.4 cm.
- Diameter: 6.5 mm.

Flecha tahitiana de acero inoxidable con una rebaba única situada en la parte superior.

- Fuerza de tensión: 750N/mm<sup>2</sup>.
- Rebaba: 7,4 cm.
- Diámetro: 6,5 mm.

LENGTH   LONGITUD	80 cm	90 cm	105 cm
COD.	132-23/6,5X80	132-23/6,5X90	132-23/6,5X105

LENGTH   LONGITUD	115 cm	120 cm	130 cm	140 cm
COD.	132-23/6,5X115	132-23/6,5X120	132-23/6,5X130	132-23/6,5X140

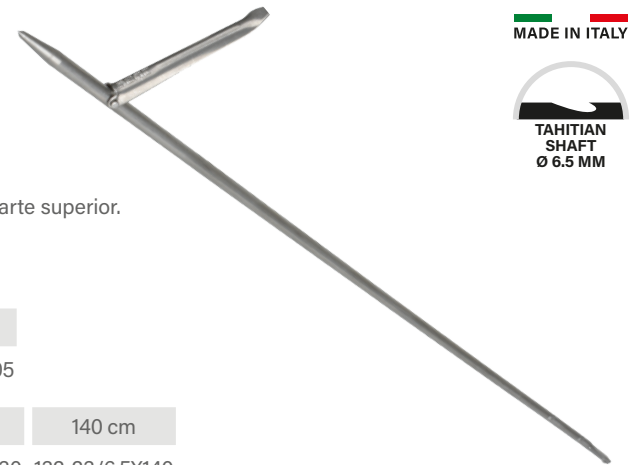

## PR 80 THREADED SHAFT FLECHA ROSCADA PR 80

MADE IN ITALY



Threaded steel shaft for spearguns.  
• Diameter: 7 mm.

Flecha roscada de acero para fusil.  
• Diámetro: 7 mm.

LENGTH   LONGITUD	50 cm	60 cm	70 cm	85 cm	95 cm	105 cm
COD.	132-9/7X50	132-9/7X60	132-9/7X70	132-9/7X85	132-9/7X95	132-9/7X105

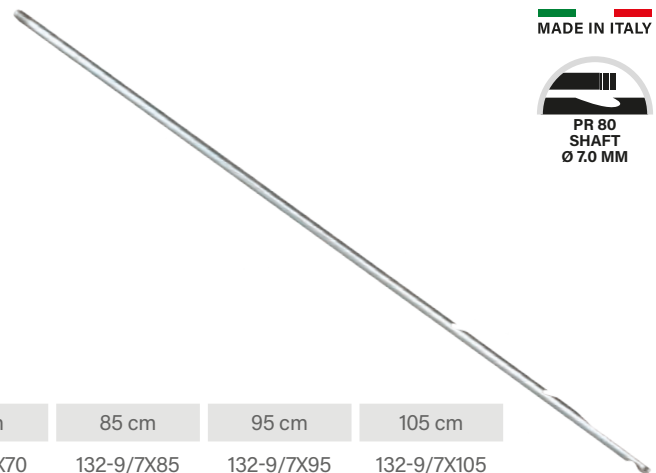

# SHAFT FOR AIR GUNS FLECHA PARA FUSILES DE AIRE

 **MADE IN ITALY**



Shaft for compressed-air guns.

Flechas para fusiles de aire comprimido.

LENGTH   LONGITUD	37.3 cm	52.3 cm	67.3 cm	77.3 cm	87.3 cm	113.3 cm	132.3 cm	
INOX Ø 7.0 mm	132-3/7X37,3	132-3/7X52,3	132-3/7X67,3	132-3/7X77,3	132-3/7X87,3	132-3/7X113,3	132-3/7X132,3	
ASSO LENGTH LONGITUD ASSO	30 cm	40 cm	50 cm	65 cm	75 cm	90 cm	115 cm	135 cm
ASSO INOX Ø 8.0 mm	132-2/8X24,3	132-2/8X37,3	132-2/8X52,3	132-2/8X67,3	132-2/8X77,3	132-2/8X87,3	132-2/8X113,3	132-2/8X132,3
ASSO Ø 8.0 mm	132-1/8X24,3	132-1/8X37,3	132-1/8X52,3	132-1/8X67,3	132-1/8X77,3	132-1/8X87,3	132-1/8X113,3	132-1/8X132,3

## ONE BARB | UNA REBABA

 **MADE IN ITALY**

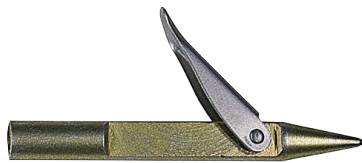

With one stainless steel barb.

Una rebaba de acero inoxidable.

COD. 122

## TWO BARBS | DOS REBABAS

 **MADE IN ITALY**

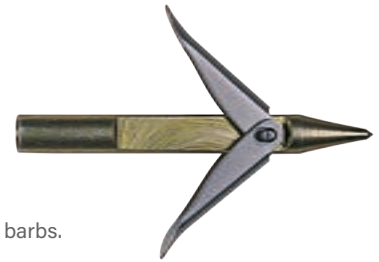

With two stainless steel barbs.

Con dos rebabas de acero inoxidable.

COD. 123

## 100% STAINLESS STEEL, TWO BARBS DOS REBABAS, 100 % ACERO INOX

 **MADE IN ITALY**



100% stainless steel with two barbs.

100 % acero inoxidable con dos rebabas.

COD. 125

## ZUM ONE BARB ZUM UNA REBABA

 **MADE IN ITALY**



100% stainless steel with one barb.

100 % acero inoxidable con una rebaba.

COD. 135M

## MINI MIG

 **MADE IN ITALY**



100% stainless steel with two short barbs.

100 % acero inoxidable con dos rebabas cortas.

COD. 134

## MINI CONCORDE

 **MADE IN ITALY**



Conical tip, 100% stainless steel.

Punta cónica, 100 % acero inoxidable.

COD. 138

**KILLER 3P LIGHT  
KILLER 3P LIGERO**

3 pronged tempered light head, Nylon body. Killer series, produced in special highly resistant, high quality steel.

Cabezal liviano templado con 3 puntas, cuerpo de nailon. Serie Killer, producida en un acero de primera calidad, especialmente resistente.



COD. 136-12/3L

**KILLER 4P LIGHT  
KILLER 4P LIGERO**

4 pronged tempered light head, Nylon body. Killer series, produced in special highly resistant, high quality steel.

Cabezal liviano templado con 4 puntas, cuerpo de nailon. Serie Killer, producida en un acero de primera calidad, especialmente resistente.



COD. 136-12/4L

**KILLER 3P HEAVY  
KILLER 3P PESADO**

3 pronged tempered heavy head, Nylon body. Killer series, produced in special highly resistant, high quality steel.

Cabezal pesado templado con 3 puntas, cuerpo de nailon. Serie Killer, producida en un acero de primera calidad, especialmente resistente.



COD. 136-12/3P

**KILLER 4P HEAVY  
KILLER 4P PESADO**

4 pronged tempered heavy head, Nylon body. Killer series, produced in special highly resistant, high quality steel.

Cabezal pesado templado con 4 puntas, cuerpo de nailon. Serie Killer, producida en un acero de primera calidad, especialmente resistente.



COD. 136-12/4P

**KILLER 3P SPECIAL**

3 pronged head, Nylon body, tempered Special prongs. Killer series, produced in special highly resistant, high quality steel.

Cabezal con 3 puntas, cuerpo de nailon, puntas Special templadas. Serie Killer, producida en un acero de primera calidad, especialmente resistente.



COD. 136-13/3

**KILLER 5P SPECIAL  
KILLER 5 STK. SPECIAL**

5 pronged head, Nylon body, tempered Special prongs. Killer series, produced in special highly resistant, high quality steel. Also available with dual tipped central barb (D/A).

5 puntas Special templadas y con base de nailon. Serie Killer producida en un acero de primera calidad, especialmente resistente. También disponible con rebabas dobles (R/D).



(D/A)



MODEL   MODELO	SPECIAL	SPECIAL (D/A)
COD.	136-13/5	136-13/5-DA

**STEEL 3P HEAVY  
ACERO 3P PESADO**

3 heavy spears in special zinc-plated steel, steel base.

3 lanzas pesadas, hechas en acero especial con baño de zinc y base de acero.



COD. 136-4/3P

**STEEL 5P HEAVY  
ACERO 5P PESADO**

5 heavy spears in special zinc-plated steel, steel base.

5 lanzas pesadas, hechas en acero especial con baño de zinc y base de acero.



COD. 136-4/5P



# KILLER FORKED SHAFT | FLECHA DE TRIDENTE KILLER



Forked shaft with 4 removable prongs in 2 pieces.  
Length: 140 cm.

Forked shaft with four prongs.  
Length: 80 cm.

Flecha de tridente con 4 puntas extraíbles en 2 unidades.  
Longitud: 140 cm.

Flecha de tridente con cuatro puntas.  
Longitud: 80 cm.



LENGTH   LONGITUD	80 cm	140 cm
COD.	143-2/80	143-2/140

## POLPONE

MADE IN ITALY



Spring-loaded speargun with anodized aluminum barrel.  
• Length: 60 cm.  
• Shaft included.

Fusil cargado con muelle con cañón de aluminio anodizado.  
• Longitud: 60 cm.  
• Flecha incluida.

POLPONE 26001/50

THREADED SHAFT | FLECHA ROSCADA 132-10/7X37,5



## Fins | Aletas

Lightweight, responsive, and comfortable. These are the basic characteristics around which the entire design of SEAC® spearfishing fins revolves. To allow freedivers and fishermen to remain underwater for prolonged periods and to deliver maximum power at the right time, it's crucial to design the footpockets to be as comfortable and functional as possible. At SEAC®, we work tirelessly to create superior quality fins every time, relying on this research on ergonomics and on the design of blades in various materials and lengths.

Liviano, adaptable y cómodo. Éstas son las características básicas sobre las cuales se basa todo el diseño de las aletas para pesca submarina de SEAC®. Para permitir que los buceadores y pescadores permanezcan bajo el agua durante períodos de tiempo más prolongados, y para ofrecer una potencia máxima en el momento correcto, es fundamental diseñar calzantes que ofrezcan la mayor comodidad y funcionalidad posibles. En SEAC®, trabajamos incansablemente para crear aletas de calidad superior, confiando en la investigación realizada sobre ergonomía y en el diseño de palas de diversos materiales y longitudes.





# MOTUS CARBON

MADE IN FRANCE

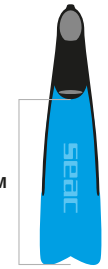

- Model: interchangeable carbon blade fin with closed foot pocket.
- Foot pocket: made in two materials with different densities. Hard thermoplastic rubber for the sole and ribs, and soft around the foot to optimize the comfort/performance ratio. 22° angle between the blade and the foot pocket to optimize thrust.
- Blade material: Unidirectional 100% pre-preg carbon and internal reinforcements in carbon with 45° weave.

- Modelo: aleta con pala de carbono intercambiable y calzante cerrado.
- Calzante: hecho en dos materiales con dos densidades diferentes. Goma termoplástica más dura en la parte de la suela y las crestas, y más suave alrededor del pie para una mejora de la relación comodidad-rendimiento. Ángulo de 22° entre la pala y el calzante para un impulso mejorado con el mismo esfuerzo.
- Material de la pala: 100 % carbono preimpregnado unidireccional y refuerzos internos en carbono con un tejido de 45°.

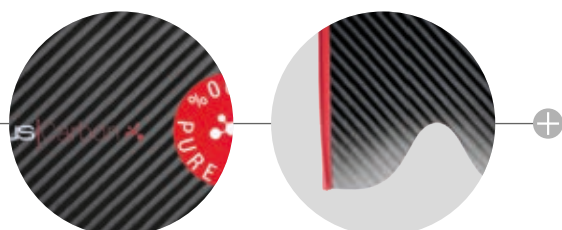

SIZE   TALLA	36/38	39/40	41/42	43/44	45/46	47/48
COD.	71-40N/36-38	71-40N/39-40	71-40N/41-42	71-40N/43-44	71-40N/45-46	71-40N/47-48



# MOTUS | MOTUS CAMO

MADE IN ITALY



- Model: interchangeable blade fin with closed foot pocket.
- Foot pocket material: made in two materials with different densities. Hard thermoplastic rubber for the sole and ribs, and soft around the foot to optimize the comfort/performance ratio. 22° angle between the blade and the foot pocket to optimize thrust.
- Blade material: special technopolymer with a formula that emphasizes the flexibility and responsiveness of the blade.
- Finish (camo): The special brown, green, red and blue camouflage effect is achieved using ICS (injection color system) technology.

- Modelo: aleta con pala intercambiable y calzante cerrado.
- Material del calzante: hecho en dos materiales con dos densidades diferentes. Goma termoplástica más dura en la parte de la suela y las crestas, y más suave alrededor del pie para una mejora de la relación comodidad-rendimiento. Ángulo de 22° entre la pala y el calzante para un impulso mejorado con el mismo esfuerzo.
- Material de la pala: tecnopolímero especial cuya formulación pone en relieve la capacidad de flexibilidad y reactividad de la pala.
- Acabado (camuflaje): El notorio efecto mimético marrón, verde, rojo y azul se obtiene gracias a la tecnología ICS (injection color system).

SIZE   TALLA	36/38	39/40	41/42	43/44	45/46	47/48
BLACK	71-25N/36-38	71-25N/39-40	71-25N/41-42	71-25N/43-44	71-25N/45-46	71-25N/47-48
GREEN CAMO	71-25CV/36-38	71-25CV/39-40	71-25CV/41-42	71-25CV/43-44	71-25CV/45-46	71-25CV/47-48
BROWN CAMO	71-25CM/36-38	71-25CM/39-40	71-25CM/41-42	71-25CM/43-44	71-25CM/45-46	71-25CM/47-48
RED CAMO	71-25CR/36-38	71-25CR/39-40	71-25CR/41-42	71-25CR/43-44	71-25CR/45-46	71-25CR/47-48
BLUE CAMO	71-25CB/36-38	71-25CB/39-40	71-25CB/41-42	71-25CB/43-44	71-25CB/45-46	71-25CB/47-48
GREY CAMO	71-25CG/36-38	71-25CG/39-40	71-25CG/41-42	71-25CG/43-44	71-25CG/45-46	71-25CG/47-48

# MOTUS BLADES | PALA MOTUS

NEW COLOR

NEW



Each package contains one replacement blade

Una sola pala para embalaje

COLOR	CARBON	BLACK	BLUE CAMO	GREEN CAMO	BROWN CAMO	RED CAMO	GREY CAMO
COD.	73-28N	73-17N	73-27B	73-27V	73-27M	73-27R	73-27G

## MOTUS FIN FOOT POCKET CALZANTE DE LA ALETA MOTUS



SIZE   TALLA	36/38	39/40	41/42	43/44	45/46	47/48
COD.	73-16N/36-38	73-16N/39-40	73-16N/41-42	73-16N/43-44	73-16N/45-46	73-16N/47-48

## MOTUS FIN ASSEMBLY KIT KIT DE MONTAJE DE LA ALETA MOTUS



COD. 73-19

# SHOUT CAMO

MADE IN ITALY



- Model: rigid long-blade fin designed to deliver optimal propulsion under all conditions.
- Foot pocket material: made in thermoplastic rubber, highly prized for its comfort, and designed for use with a neoprene boot.
- Blade material: thermoplastic technopolymer with a high modulus of elasticity. The special grey, brown, and green camouflage effect is achieved using ICS (injection color system) technology.
- Modelo: aleta de pala larga para ofrecer una propulsión óptima bajo cualquier condición.
- Material del calzante: hecho en goma termoplástica, altamente destacada por su comodidad y diseñada para usar con un escaquin de neopreno.
- Material de la pala: tecnopolímero termoplástico con un módulo de elasticidad. El efecto especial de camuflaje en gris, marrón y verde se ha logrado usando la tecnología ICS (sistema de color por inyección).

SIZE   TALLA	39/40	41/42	43/44	45/46	47/48
GREY CAMO	71-44CG/39-40	71-44CG/41-42	71-44CG/43-44	71-44CG/45-46	71-44CG/47-48
BROWN CAMO	71-44CM/39-40	71-44CM/41-42	71-44CM/43-44	71-44CM/45-46	71-44CM/47-48
GREEN CAMO	71-44CV/39-40	71-44CV/41-42	71-44CV/43-44	71-44CV/45-46	71-44CV/47-48

# TALENT CAMO

MADE IN ITALY

NEW COLOR



NEW

- Model: rigid medium-long-blade fin designed for use in shallow water.
- Foot pocket material: made in thermoplastic rubber, highly prized for its comfort, and designed for use with a neoprene boot.
- Blade material: thermoplastic technopolymer with a high modulus of elasticity. The special grey, brown, and green camouflage effect is achieved using ICS (injection color system) technology.
- Modelo: aleta de pala mediana-larga, diseñada para usar en aguas poco profundas.
- Material del calzante: hecho en goma termoplástica, altamente destacada por su comodidad y diseñada para usar con un escaquin de neopreno.
- Material de la pala: tecnopolímero termoplástico con un módulo de elasticidad. El efecto especial de camuflaje en gris, marrón y verde se ha logrado usando la tecnología ICS (sistema de color por inyección).

SIZE   TALLA	39/40	41/42	43/44	45/46	47/48
GREY CAMO	71-24CG/39-40	71-24CG/41-42	71-24CG/43-44	71-24CG/45-46	71-24CG/47-48
BROWN CAMO	71-24CM/39-40	71-24CM/41-42	71-24CM/43-44	71-24CM/45-46	71-24CM/47-48
GREEN CAMO	71-24CV/39-40	71-24CV/41-42	71-24CV/43-44	71-24CV/45-46	71-24CV/47-48
ORANGE CAMO	71-24CR/30-40	71-24CR/41-42	71-24CR/43-44	71-24CR/45-46	71-24CR/47-48

50 CM

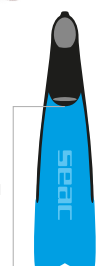





SEA

TEMPERED GLASS

SEA



## Masks and snorkels | Máscaras y esnórqueles

With a camouflage design coordinated with our full line of equipment, the shapes and colors of our masks are designed to meld seamlessly with both the fisherman and the seabed and surrounding environment.

The masks are made of opaque silicone, making them non-reflective, which helps camouflage them, and they are smaller in size to fit comfortably and take up as little space as possible while you're in the water.

To round out our camouflage lines and more, we offer simple and functional snorkels for underwater spearfishing.

Made of quality liquid silicone with unique camouflage colors, each product can be matched with a mask, fins, and suit.

Con un diseño de camuflaje que se ha coordinado con toda la línea de equipos completa, las tonalidades y los colores de nuestras máscaras se han diseñado para poder camuflarse perfectamente tanto con el pescador como con el lecho y el entorno marino en donde éste se halle. Las máscaras se fabrican a partir de una silicona opaca, haciendo que no sean reflectantes, lo cual ayuda a camuflarlas mejor, y son más pequeñas de tamaño para ajustarse cómodamente y ocupar el menor espacio posible mientras está en el agua.

Para completar nuestras líneas de camuflaje, entre otros, ofrecemos unos tubos de esnórquel que son sencillos y funcionales para la práctica de pesca submarina. Fabricados a partir de una silicona líquida de alta calidad con unos exclusivos colores de camuflaje, cada uno de estos productos permite combinarse con una máscara, aletas y el traje de buceo.





# M70

ITALIAN DESIGN



- Model: Mask made with semi-frameless technology. The internal volume has been reduced so far that the diver almost never needs to equalize.
- Frame: semi-frameless technology with the skirt overmolded directly onto the frame.
- Skirt: High quality opaque liquid silicone.
- Lenses: in 3-mm tempered glass.
- Buckle: 3D pivoting directly on the skirt.
- Packaging: transparent rigid box.
- Other features: the anatomical skirt offers optimal comfort for different shapes of faces. The field of vision is ample because the lenses are very close to the eyes. Liquid silicone with special non-reflective opaque treatment.

- Modelo: máscara fabricada a partir de la tecnología de semimontura. Se ha reducido el volumen interno de modo que el buceador casi nunca necesita ecualizar.
- Color: marrón, azul y rojo.
- Montura: tecnología de semi-montura con faldón sobremoldado directamente sobre la montura.
- Faldón: silicona líquida de alta calidad con un tratamiento opaco.
- Lentes: cristal templado de 3 mm.
- Hebilla: oscilante en 3D directamente sobre el faldón.
- Embalaje: caja rígida transparente.
- Otras prestaciones: faldón anatómico que ofrece una comodidad óptima para las diferentes formas de rostros. El campo de visión es amplio porque las lentes están muy cerca de los ojos. Silicona líquida con un tratamiento especial opaco no reflectante.

MODEL   MODELO	S/COL
BLACK	75-30N/SBL
BLUE	75-30B/SB
BROWN	75-30M/SBR
RED	75-30R/SR



6 pieces/unit  
6 unidades/código



# TOUCH

ITALIAN DESIGN



- Structure: silicone mounted with "frameless" technology.
- Skirt: liquid silicone with differentiated thicknesses, comfortable, compact, and smaller in volume.
- Lens: single lens in tempered glass.
- Buckles: dual button.
- Design: designed and manufactured in Italy.
- Packaging: transparent rigid box included.
- Other features: opaque colored Comfort Silicone skirt. Frameless technology with reduced internal volume. Strap customized with SEAC logo.

- Estructura: silicona montada con la tecnología «sin montura».
- Faldón: silicona líquida con diferentes grosores, cómoda, compacta y más pequeña en volumen.
- Lentes: lente única con cristal templado.
- Hebillas: botón doble.
- Diseño: creado y fabricado en Italia.
- Embalaje: incluye una caja rígida transparente.
- Otras prestaciones: faldón de silicona Comfort en color opaco. Tecnología sin montura con volumen interno reducido. Correa personalizada con el logotipo de SEAC.

MODEL   MODELO	S/COL
BLACK	75-55N/SBL
BLUE	75-55B/SB



6 pieces/unit  
6 unidades/código





# ONE CAMO

ITALIAN DESIGN



- Model: mask with reduced internal volume.
- Color: camouflage achieved using Water Transfer Film technology coordinated with SEAC camo lines.
- Frame: in polycarbonate.
- Skirt: High quality with opaque treatment liquid silicone.
- Lenses: 3-mm tempered glass.
- Optical lenses: available from -1.00 to -6.00.
- Buckle: integrated into the frame.
- Packaging: transparent rigid box.

- Modelo: máscara sin montura con volumen interno reducido.
- Color: el camuflado se logra a través de la tecnología Water Transfer Film coordinada con las líneas de camuflado de SEAC.
- Montura: de policarbonato.
- Faldón: silicona líquida de alta calidad con un tratamiento opaco.
- Lentes: cristal templado de 3 mm.
- Lente óptica: disponible desde -1,00 hasta -6,00.
- Hebilla: integrada en la montura.
- Embalaje: incluye una caja rígida transparente.



6 pieces/unit  
6 unidades/código



OPTIONAL OPTICAL LENSES  
-1.0 to -6.0



TEMPERED GLASS



PURE SILICONE

MODEL   MODELO	S/COL
GREY CAMO	9449CG
BROWN CAMO	9451CM
GREEN CAMO	9452CV
BLUE CAMO	9450CB
BLACK CAMO	9449K



NEW

# ONE | ONE PRO

ITALIAN DESIGN



6 pieces/unit  
6 unidades/código



- Frame: polycarbonate.
- Skirt: hypoallergenic liquid silicone.
- Strap: silicone.
- Lenses: in tempered glass.
- Optical lenses: options from -1.0 to -6.0.
- Packaging: transparent rigid box included.
- Other features: anatomical skirt in high-quality liquid silicone.
- Buckle on the frame with Easy Touch system.
- Option to mount optical lenses.

- Montura: policarbonato.
- Faldón: silicona líquida hipoalergénica.
- Tira: silicona.
- Lentes: en cristal templado.
- Lente óptica: opciones de -1,0 a -6,0.
- Embalaje: incluye una caja rígida transparente.
- Otras prestaciones: nuevo faldón anatómico en silicona líquida de gran calidad. Hebilla en la montura con el sistema Easy Touch.
- Opción para cambiar a lente óptica.



OPTIONAL OPTICAL LENSES  
-1.0 to -6.0



TEMPERED GLASS



PURE SILICONE

ONE 9449N

ONE PRO 75-56N/SBL

OPTIONAL ACTION CAM ADAPTER  
ADAPTADOR OPCIONAL PARA ACTION CAM  
0780019



# EXTREME CAMO

ITALIAN DESIGN



- Model: mask with reduced internal volume.
- Color: exclusive camouflage achieved using Water Transfer Film technology coordinated with SEAC camo lines.
- Frame: in polycarbonate.
- Skirt: High-quality anatomical liquid silicone.
- Lenses: 3-mm tempered glass.
- Optical lenses: available from -1.00 to -6.00.
- Buckle: integrated into the frame with Easy Touch system.
- Packaging: transparent rigid box.
- Other features: option to mount optical lenses.

- Modelo: máscara sin montura con volumen interno reducido.
- Color: el camuflado se logra a través de la tecnología Water Transfer Film coordinada con las líneas de camuflado de SEAC.
- Montura: de policarbonato.
- Faldón: silicona líquida anatómica de alta calidad.
- Lentes: cristal templado de 3 mm.
- Lente óptica: disponible desde -1,00 hasta -6,00.
- Hebilla: integrada en la montura con el sistema Easy Touch.
- Embalaje: incluye una caja rígida transparente.
- Otras Prestaciones: opción para cambiar a lente óptica.



6 pieces/unit  
6 unidades/código



OPTIONAL OPTICAL LENSES  
-1.0 to -6.0



TEMPERED GLASS



PURE SILICONE

MODEL   MODELO	S/COL
GREY CAMO	75-33CG/SBL
BROWN CAMO	75-33K/SBR
GREEN CAMO	75-33PR/SGR
BLUE CAMO	75-33MK/SB



# EXTREME

ITALIAN DESIGN



TEMPERED GLASS



PURE SILICONE



6 pieces/unit  
6 unidades/código



OPTIONAL OPTICAL LENSES  
-1.0 to -6.0

- Frame: polycarbonate.
- Skirt: hypoallergenic liquid silicone.
- Strap: silicone.
- Lenses: in tempered glass.
- Optical lenses: options from -1.0 to -6.0.
- Other features: buckle on the skirt featuring the Tubing Connected System that ensures a secure seal and minimizes the pressure of the mask against your face. New anatomical skirt in high-quality liquid silicone. Option to mount optical lenses.

- Montura: policarbonato.
- Faldón: silicona líquida hipoalergénica.
- Tira: silicona.
- Lentes: en cristal templado.
- Lente óptica: opciones de -1,0 a -6,0.
- Otras prestaciones: Hebilla en el faldón que incorpora el sistema Tubing Connected para garantizar un sellado seguro y que minimiza la presión de la máscara contra la cara. Nuevo faldón anatómico en silicona líquida de gran calidad. Opción para cambiar a lente óptica.



COD. 75-33N/SBL

# COVE

ITALIAN DESIGN



- Frame: polycarbonate.
- Skirt: hypoallergenic liquid silicone.
- Strap: silicone.
- Lenses: in tempered glass.
- Other features: anatomical skirt in high-quality liquid silicone. Adjustable buckle anchored on the frame.

- Montura: policarbonato.
- Faldón: silicona líquida hipoalergénica.
- Tira: silicona.
- Lentes: en cristal templado.
- Otras prestaciones: nuevo faldón anatómico en silicona líquida de gran calidad. Hebilla ajustable fijada en la montura.



6 pieces/unit  
6 unidades/código



COD. 75-58N/SBL

## SET BIS EXTREME



NEW



6 pieces/unit  
6 unidades/código



Silicone sets ideal for underwater spearfishing and freediving, with a EXTREME mask and TOP FLEX snorkel.

Conjuntos de silicona ideales para pesca submarina y apnea, con máscara EXTREME y tubo de esnórquel TOP FLEX.

COD. 89-24N



## SET BIS COVE

ITALIAN DESIGN



NEW



6 pieces/unit  
6 unidades/código



Silicone sets ideal for underwater spearfishing and freediving, with a COVE mask and TOP FLEX snorkel.

Conjuntos de silicona ideales para pesca submarina y apnea, con máscara COVE y tubo de esnórquel TOP FLEX.

COD. 89-84N





## LIQUID

ITALIAN DESIGN



12 pieces/unit  
12 unidades/código

- Model: 100% High Quality Liquid Silicone snorkel.
- Tube: differentiated cross section designed to ensure excellent breathing and allow the diver to expel water quickly and efficiently. We chose 100% silicone for two main reasons: it's the only material that doesn't change its characteristics or its behavior based on the temperature, and it has sufficient memory to recover its original shape even after being deformed for long periods.
- Mouthpiece: ergonomic in hypoallergenic silicone.

- Modelo: esnórquel 100 % de silicona líquida de alta calidad.
- Tubo: sección transversal diferenciada y diseñada para garantizar una respiración excelente y permitir al buceador expulsar el agua de una manera rápida y eficaz. Hemos elegido un material de 100 % silicona por dos razones principales: es el único material que no cambia sus propiedades o su comportamiento basado en la temperatura, y que tiene memoria de recuperación hacia su forma original, incluso después de haberse deformado durante largos periodos.
- Boquilla: ergonómica, de silicona hipoalérgica.

MODEL   MODELO	S/BL	S/COL
RED	-	84-23R/SR
BLUE	-	84-23B/SB
BLACK	84-23N/SBL	-



## TOP FLEX

ITALIAN DESIGN



12 pieces/unit  
12 unidades/código

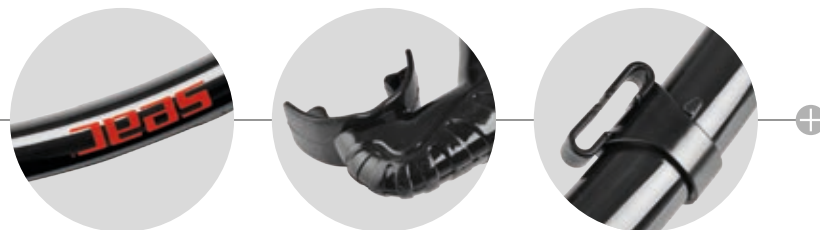

- Model: conceived specifically for spearfishing and freediving, this snorkel was designed to ensure maximum comfort even after many hours of use.
- Mouthpiece material: liquid silicone.
- Modelo: concebido específicamente para la práctica de la pesca submarina y el buceo en apnea, este esnórquel se ha diseñado para garantizar una comodidad máxima incluso después de muchas horas de uso.
- Material de la boquilla: silicona líquida.



COD. 84-34N/SBL

# JET - JET CAMO

ITALIAN DESIGN



12 pieces/unit  
12 unidades/código

- Model: anatomically shaped snorkel.
- Mouthpiece material: liquid silicone.
- Tube (JET): plastic technopolymer.
- Tube (JET CAMO): plastic technopolymer with special camouflage covering achieved using Water Transfer Film technology.

- Modelo: esnórquel modelado anatómicamente.
- Material de la boquilla: silicona líquida.
- Tubo (JET): tecnopolímero plástico.
- Tubo (JET CAMO): tecnopolímero plástico con recubrimiento de camuflaje especial que se logra a través del uso de la tecnología Water Transfer Film.

MODEL   MODELO	S/BL	S/COL
BLACK	484N	-
BLUE	-	486B
BROWN	-	487M
GREEN	-	488V
GREY CAMO	-	484CG
BROWN CAMO	-	487CM
GREEN CAMO	-	488CV
BLUE CAMO	-	486CB

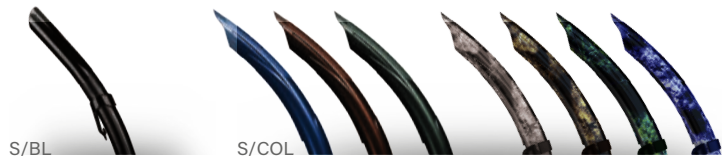

# TURTLE

ITALIAN DESIGN



12 pieces/unit  
12 unidades/código

- Model: snorkel entirely in silicone.
- Tube: in folding silicone with elastic memory that always returns to its original shape, even after being deformed for long periods. Model with snorkel carrying shell included.

- Modelo: esnórquel hecho totalmente de silicona.
- Tubo: en silicona que permite doblarse y memoria elástica que regresa siempre a su forma original, incluso después de haberse deformado durante largos periodos de tiempo. Modelo que incluye una bolsa protectora para transporte.



COD. 84-31N/SBL







## Torches and knives | Linternas y cuchillos

The very finest materials and highly functional precision components make SEAC® torches some of the most beloved with customers.

SEAC® offers a wide range of dive knives made with tempered stainless steel blades to ensure the most reliable possible knife for both quality and performance.

Gracias a nuestros materiales de la mayor calidad y unos componentes de precisión altamente funcionales, las linternas SEAC® han pasado a ser uno de los productos más queridos por nuestros clientes.

SEAC® ofrece una amplia gama de cuchillos de buceo fabricados a partir de hojas de acero inoxidable templado para garantizar un producto final de un cuchillo lo más fiable posible tanto en calidad como en rendimiento.



## R15

Aluminum dive torch with tempered optical glass.

- Dimensions: diameter 47 mm - length 166 mm.
- Weight: 300 gr.
- 1 CREE XP-L LED.
- Battery: Li-Ion 18650 inside the torch, rechargeable via Micro-USB.
- Burn-time: 2 hours at max power - 4 hours at reduced power.
- Width of light beam: zoom adjustable, from 12° to 75°.
- On switch: electromagnetic system.
- Operating modes: light intensity adjustable using magnetic switch.
- Maximum operating depth: 100 mt.
- Light intensity: 900 Lumens.
- Universal torch strap: included.
- Switch lock to prevent accidental ignition.



Linterna para buceo de aluminio con vidrio óptico templado.

- Dimensiones: diámetro 47 mm - longitud 166 mm.
- Peso: 300 gr.
- 1 LED CREE XP-L.
- Batería: ion de litio 18650 en el interior de la linterna, recargable mediante cable micro USB.
- Horas de funcionamiento: 2 horas de luz máxima - 4 horas con energía reducida.
- Amplitud del haz de luz: zoom ajustable, de 12° a 75°.
- Botón de encendido: Sistema electromagnético.
- Modos de funcionamiento: intensidad de la luz ajustable usando el interruptor magnético.
- Profundidad máxima de funcionamiento: 100 m.
- Intensidad de la luz: 900 lúmenes.
- Correa universal para linterna: incluida.
- Traba del botón para evitar encendido accidental.



OPTIONAL  
COD. 0530104



COD. 50-25/AN



## R3FX

Aluminum dive torch with tempered optical glass.

- Dimensions: diameter 42 mm - length 140 mm.
- Weight: 255 gr.
- 1 Cree XPG2 LED.
- Battery: 18650 Li-Ion rechargeable using external battery charger with USB connection.
- On switch: electromagnetic system.
- Operating modes: ON/OFF.
- Maximum operating depth: 100 m.
- Light intensity: 400 Lumens.
- Burn-time: 2 hours at max power - 8 hours at reduced power.
- Universal torch strap: included.
- Switch lock to prevent accidental ignition.



Linterna para buceo de aluminio con vidrio óptico templado.

- Dimensiones: diámetro 42 mm - longitud 140 mm.
- Peso: 255 gr.
- 1 LED CREE XPG2.
- Batería: 18650 de ion de litio recargable mediante cargador de baterías externo con conexión USB.
- Botón de encendido: sistema electromagnético.
- Modos de funcionamiento: Encendido/Apagado.
- Profundidad máxima de funcionamiento: 100 m.
- Intensidad de la luz: 400 lúmenes.
- Horas de funcionamiento: 2 horas de luz máxima - 8 horas con energía reducida.
- Correa universal para linterna: incluida.
- Traba del botón para evitar encendido accidental.



OPTIONAL  
COD. 0530104



COD. 50-23/AN





## T5

Aluminum dive torch with tempered optical glass.

- Dimensions: diameter 31.9 mm - length 144 mm.
- Weight: 125 gr.
- 1 CREE XPG2 LED.
- Battery: 3 x Alkaline AAA.
- Burn-time: 2.2 hours.
- Width of light beam: 9°.
- On switch: press.
- Maximum operating depth: 100 mt.
- Light intensity: 300 Lumens.
- Universal torch strap: included.
- Switch lock to prevent accidental ignition.

Linterna para buceo de aluminio con vidrio óptico templado.

- Dimensiones: diámetro 31,9 mm - longitud 144 mm.
- Peso: 125 gr.
- 1 LED CREE XPG2.
- Batería: 3 baterías alcalinas AAA.
- Horas de funcionamiento: 2,2 horas.
- Amplitud del haz de luz: 9°.
- Botón de encendido: presionar.
- Profundidad máxima de funcionamiento: 100 m.
- Intensidad de la luz: 300 lúmenes.
- Correa universal para linterna: incluida.



OPTIONAL  
COD. 0530104

OPTIONAL RECHARGEABLE  
BATTERY  
BATERÍA RECARGABLE OPCIONAL  
COD. 0530097

OPTIONAL BATTERY CHARGER  
CARGADOR DE BATERÍA OPCIONAL  
COD. 0530098

USB CABLE  
CABLE USB  
0530099

COD. 50-26/AN



## Q5

Technopolymer dive torch.

- Type of batteries: Eight 1.5 V AA/R6 alkaline batteries (not included).
- Burn time: 3 hrs at max power.
- Maximum usage depth: 60 m.
- Dimensions: diameter 60 mm - length 180 mm.
- Weight: 457 gr (with batteries).
- On switch: electromagnetic system.
- Seal: Double radial seal O-ring + L-Ring.
- Glass: clear polycarbonate.
- Lumens: 700 Lumens.
- 3 Cree XPG R5 LEDs.
- Universal torch strap: included.

Tipo de pila: Ocho baterías alcalinas 1,5 V AA/R6 (no incluidas).

- Autonomía: 3 horas en el modo energía máxima.
- Profundidad máxima de funcionamiento: 60 m.
- Dimensiones: diámetro 60 mm - longitud 180 mm.
- Peso: 457 gr. (con baterías).
- Botón de encendido: sistema electromagnético.
- Sellado: Junta tórica con sellado de doble radial.
- Vidrio: policarbonato transparente.
- Lúmenes: 700 lúmenes.
- 3 Cree XPG R5 LEDs.
- Correa universal para linterna: incluida.



OPTIONAL  
COD. 0530104



COD. 50-20/N





## TITANIUM

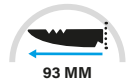
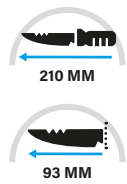

STRAPS INCLUDED  
CORREAS INCLUIDAS



Serrated edge titanium blade. Very lightweight. "Double Release System" lets you pull the knife out one-handed. It can be fastened to the weight belt, arm, or calf.

Hoja de titanio con borde serrado. Muy ligero. Sistema de liberación doble, que le permite jalar del cuchillo con una sola mano. Se puede ajustar al cinturón de lastre, al brazo o a la pantorrilla.

COD. 55-22/N

## SHARP

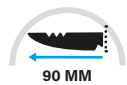

STRAPS INCLUDED  
CORREAS INCLUIDAS



Stiletto-shaped blade and serrated edge. "Double Release System" lets you pull the knife out one-handed. Can be fastened to the arm or calf. Reversible fastening.

Hoja de forma típica tipo estilete y borde con sierra. Sistema de liberación doble, que le permite jalar del cuchillo con una sola mano. Se puede ajustar al brazo o a la pantorrilla. Ajuste reversible.

COD. 55-25/NG

## RAPID DAGA

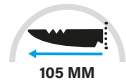
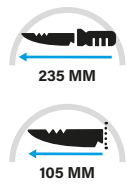

AISI 420 tempered steel blade. Typical stiletto shape.  
 Dual-material ergonomic handle with end-cap hammer. Sheath with Easy Lock system.  
 Reversible fastening.  
 It can be fastened to the weight belt, arm, or calf.

Hoja de acero templado AISI 420. Forma típica tipo estilete.  
 Empuñadura ergonómica de material doble, con mazo al final de la empuñadura. Vaina con sistema Easy Lock.  
 Ajuste reversible.  
 Se puede ajustar al cinturón de lastre, al brazo o a la pantorrilla.

COD. 55-24/NG

NEW

STRAPS INCLUDED  
 CORREAS INCLUIDAS



## RIP FISH

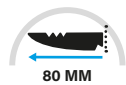

STRAPS INCLUDED  
 CORREAS INCLUIDAS



Dive knife with Dagger type blade, featuring asymmetrical milling and sharpening on both sides. Especially well-suited for spearfishing, when you need to use it quickly for both cutting and filleting. Knife 175 mm long with 75 mm blade. 3.5 mm thick. 57 Hrc hardness steel (Rockwell scale). Upper section of the blade with wide-tooth serrations and lower section with straight edge. Includes connection ties and kit for fastening line. Removable grip makes it easy to clean the blade. Shockproof sheath with Rip Lock safety feature.

Cuchillo de buceo tipo daga con hoja asimétrica y afilada en ambos lados. Especialmente pensado para la pesca submarina, cuando se necesita cortar y filetear. Cuchillo de 175 mm de largo y hoja de 75 mm. 3,5 mm de grosor. Acero con una dureza de 57 HRC (escala Rockwell). Incluye una sección superior de la hoja con sierra de dientes anchos y una sección inferior de borde recto. También presenta un sistema de ataduras y kit para sujeción a la línea. Empuñadura extraíble para un mejor limpiado de la hoja. Vaina a prueba de impacto con sistema de seguridad Rip Lock.

COD. 1754

## SAMURAI

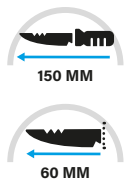

Tempered and polished stainless steel blade for maximum resistance to corrosion.

Hoja de acero inoxidable templado y pulido para una resistencia máxima a la corrosión.

SAMURAI		
☐	WHITE	55-16/W
■	BLACK	55-16/N
■	RED	55-16/R
■	GREEN	55-16/V



## DEVIL HD

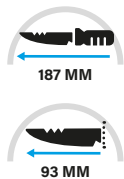

STRAPS INCLUDED  
CORREAS INCLUIDAS



Knife with special tempered stainless steel blade, with stiletto shape designed specifically for underwater spearfishing. Excellent penetration and cutting ability on both edges, straight and serrated. Click sheath with Push & Pull Out system that can be operated one-handed, even when wearing gloves.

Cuchillo con una hoja en acero inoxidable templado especial y una forma tipo estilete diseñada específicamente para la práctica de la pesca submarina. Penetración excelente y, al integrar un lado recto y otro con sierra, permite cortar por ambos costados. Vaina de clic con sistema Push & Pull Out que permite manipularse con una sola mano, incluso con los guantes puestos.

COD. 55-20/N



## Bags and accessories | Bolsas y accesorios

SEAC® offers the most complete collection of dive accessories on the market. Including buoys, nets, belts, lines, and practical bags, SEAC® always has the right accessory for every need.

SEAC® ofrece la colección más completa de accesorios para buceo del mercado. Desde boyas, redes y cinturones, hasta líneas y bolsas prácticas, SEAC® siempre tiene el accesorio correcto para cada necesidad.





## U-BOOT 130



- Waterproof bag made of tarpaulin.
- Lets you carry your equipment wet or dry.
- Side drainage hole for clearing water if you rinse your equipment after use.
- Adjustable shoulder straps.
- Dimensions: 95x40x30 cm
- Volume: 130 lt max.

- Bolsa impermeable hecha de lona.
- Le permite llevar sus equipos, secos o húmedos.
- Orificios laterales de drenaje para escurrir el agua en caso de que enjuague su equipo luego de usarlo.
- Correas ajustables para los hombros.
- Dimensiones: 95x40x30 cm
- Volumen: Máximo 130 litros.

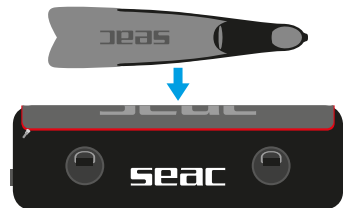

COD. 92-5/130

## U-BOOT 100



- Heat-sealed waterproof bag made of tarpaulin with no stitches.
- Lets you carry your equipment wet or dry.
- Side drainage hole for clearing water if you rinse your equipment after use.
- Dimensions: 95x31x25 cm.
- Volume: 100 lt max.

- Bolsa impermeable termosellada hecha de lona, sin costuras.
- Le permite llevar sus equipos, secos o húmedos.
- Orificios laterales de drenaje para escurrir el agua en caso de que enjuague su equipo luego de usarlo.
- Dimensiones: 95x31x25 cm.
- Volumen: Máximo 100 litros.



COD. 92-5/100

## SEAL



- Material: waterproof heavy duty heat-sealed PVC backpack.
- Dimensions: 32x32x95 cm.
- Volume: 75 l
- Material: mochila de PVC impermeable termosellada de alta resistencia.
- Dimensiones: 32x32x95 cm.
- Volumen: 75 L.



COD. 92-17

## SEAL CAMO



- Material: waterproof heavy duty heat-sealed PVC backpack.
- Dimensions: 32x32x95 cm.
- Volume: 75 l
- Material: mochila de PVC impermeable termosellada de alta resistencia.
- Dimensiones: 32x32x95 cm.
- Volumen: 75 L.



COD. 92-17CM

## U-BOOT CAMO



Roomy water resistant bag in heat-welded PVC. The structure was technically designed to carry both wet and dry equipment. Wet items can be rinsed with fresh water, and a special cap makes drainage easy.

- Material: heat-sealed 500 Denari PVC with reinforcing patches on the handles.
- Dimensions: 94x31x36 cm (105 l).
- Bolsa espaciosa e impermeable confeccionada en PVC termosoldado. La estructura presenta un diseño técnico para poder llevar equipo tanto mojado como seco. Permite lavar los elementos mojados en agua fresca, y el tapón especial que incluye permite un secado más fácil.
- Material: PVC 500 Denari termosellado con parches reforzados en las asas.
- Dimensiones: 94x31x36 cm (105 lt).

COD. 92-5CM



## FREEDIVING FIN BAG BOLSA ALETAS FREEDIVING



95x21x16 CM

NEW



- Bag designed for carrying long fins like Motus.
  - Bag dimensions: approximately 95 cm length x 21 cm width x 16 cm height.
  - Max carry weight: 4 kg.
  - Shoulder strap and upper handle.
  - Convenient opening zip and clear front window.
- Bolsa diseñada para llevar aletas largas como las Motus.
  - Dimensiones de la bolsa: aproximadamente 95 cm de longitud x 21 cm de ancho y 16 cm de alto.
  - Peso máximo que puede transportar: 4 kg.
  - Correa para el hombro y manija superior.
  - Cremallera cómoda y ventana delantera transparente.

COD. 92-22

## HIDE SPEARGUN BAG BOLSA PARA FUSIL



150 CM x Ø 25 CM



- Speargun bag with shoulder belt.
- Bag size: 150 cm long x 25 cm diameter.
  - Internal pocket with Velcro closure.
  - Reinforced bottom.
  - Velcro closure + safety buckle.
  - Cordura fabric.
  - Removable shoulder strap adjustable on 3 eyelets.

- Bolsa con bandolera para fusil de pesca.
- Tamaño de la bolsa: 150 cm de largo x 25 cm de diámetro.
  - Bolsillo interno con cierre de velcro.
  - Fondo reforzado.
  - Cierre de velcro + hebilla de seguridad.
  - Tela cordura.
  - Correa para el hombro ajustable en 3 ojales.

COD. 92-20

## BOUNTY

Inflatable board designed to accompany fishermen to their destination. Allows you to easily get where you're going and carry your extra equipment. You can also use it when you need to rest.

- Material: Heavy Duty PVC in high-visibility orange.
- Structure: large covered forepeak compartment, Velcro closure, 2 D-rings, and a mesh accessories pocket. 3 PVC air chambers. Each is independent to ensure maximum safety. The central chamber specifically is used for floating while the diver rests or moves. 4 D-rings under the keel for towing or anchoring additional equipment. 4 elastic side straps for fastening shafts and/or spearguns. 2 fabric handles on the bow covered with plastic tubing. 1 Alpha bow flag.
- Dimensions: 80x55 cm.

- Tabla inflable diseñada para acompañar a los pescadores a su destino. Le ayuda a llegar allá donde vaya y llevar encima equipo extra. También puede usarlo cuando necesite descansar.
- Material: PVC resistente, en color anaranjado para una mayor visibilidad.
- Estructura: gran compartimento tipo mampara forrado, cierre con Velcro, 2 anillas en D y un bolsillo de malla para accesorios. 3 cámaras de aire de PVC. Cada una es independiente de la otra para asegurar una seguridad máxima. La cámara central se ha diseñado específicamente para usarse como dispositivo de flotación mientras el buceador está descansando o moviéndose. 4 anillas en D bajo la quilla para arrastrar o sujetar cualquier equipo adicional. 4 correas elásticas en el lateral para sujetar flechas o fusiles. 2 asas hechas de tejido en el lazo recubierta en un tubo de plástico. 1 bandera con lazo Alpha.
- Dimensiones: 80 x 55 cm.



COD. 95-17

## SEAMATE

Inflatable board designed to accompany fishermen to their destination. Allows you to easily get where you're going and carry your extra equipment. You can also use it when you need to rest.

- Material: 420 D polyester with black bottom and high-visibility red on top.
- Structure: roomy forepeak pocket. Elastic side straps for attaching spearguns and shafts. 7 D-rings under the keel for towing or anchoring additional equipment. 2 handles on the bow for use when moving. 3 PVC air chambers. Each is independent to ensure maximum safety. 1 Alpha bow flag.
- Dimensions: 85x60 cm.

- Tabla inflable diseñada para acompañar a los pescadores a su destino. Le ayuda a llegar allá donde vaya y llevar encima equipo extra. También puede usarlo cuando necesite descansar.
- Material: poliéster 420 D con la parte inferior en negro y naranja en la parte superior para una mayor visibilidad.
- Estructura: espacioso bolsillo tipo mampara. Correas elásticas laterales para sujetar fusiles de pesca y flechas. 7 anillas en D bajo la quilla para arrastrar o sujetar cualquier equipo adicional. 2 asas en la mampara para usar al moverse. 3 cámaras de aire de PVC. Cada una es independiente de la otra para asegurar una seguridad máxima. 1 bandera con lazo Alpha. Dimensiones: 85 x 60 cm.



COD. 37001

### ANTIFOG BIO GEL

MADE IN ITALY



VERSION	15 ml	30 ml
COD.	111-99	1608

### LARGE BUOY BOYA GRANDE

- Height: 66 cm.
- Circumference: 121 cm.
- Line: 25 m.
- Altura: 66 cm.
- Circunferencia: 121 cm.
- Forro: 25 m.



COD. 196/D
------------

### MASTER FLAG BANDERA MASTER



<b>A</b> COD. 196/C
<b>B</b> COD. 95-3YR (ONLY FOR GREECE   SOLO PARA GRECIA)

### SMALL BUOY BOYA PEQUEÑA

- Height: 56 cm.
- Circumference: 102 cm.
- Line: 25 m.
- Altura: 56 cm.
- Circunferencia: 102 cm.
- Forro: 25 m.



COD. 195/B
------------

### TORPEDO BUOY BOYA TORPEDO



Height: 23 cm. Height + Flag: 50 cm.  
Circumference: 170 cm. Line: 25 m.

Altura: 23 cm. Altura + Bandera: 50 cm.  
Circunferencia: 170 cm. Línea: 25 m.

COD. 188/B
------------

### NEW TORPEDO BUOY NUEVA BOYA SILURO



Master Torpedo Buoy in fluorescent yellow high-visibility PVC-coated fabric. Inner bladder. 3 straps and 2 technopolymer D-Ring for towing accessories. Technopolymer D-Ring for towing. Removable marker flag and line with dual carabiner included.

Nueva boya torpedo confeccionada en PVC de alta resistencia de color amarillo fluorescente. Incluye compartimento estabilizante para llevar agua. 6 ganchos para incluir accesorios. Bandera de señalización extraíble, con cabo y doble mosquetón incluidos.

COD. 95-2Y
------------



## SPHERICAL FLUORESCENT BUOY BOYA FLUORESCENTE ESFÉRICA

- Height: 31 cm.
- Height + Flag: 57 cm.
- Circumference: 104 cm.
- Line: 25 m.

- Altura: 31 cm.
- Altura + bandera: 57 cm.
- Circunferencia: 104 cm.
- Forro: 25 m.



COD. 189/B

## LIGNE | LÍNEA



Roll of line. Package of 100 m.

Bobina de línea. Paquete de 100 m.

COD. 173

## MARSEILLES BELT CINTURÓN MARSEILLES

MADE IN ITALY



Black rubber belt with Marseilles buckle.  
• Length: 160 cm.

Cinturón de goma con hebilla Marseilles.  
• Longitud: 160 cm.

COD. 1970

## INOX BELT CINTURÓN DE ACERO INOXIDABLE

MADE IN ITALY



Black rubber belt with stainless steel buckle.  
• Length: 130 cm.

Cinturón de goma con hebilla de acero  
inoxidable. • Longitud: 130 cm.

COD. 1971

## NYLON BELT CINTURÓN DE NAILON

MADE IN ITALY



Rubber belt with nylon buckle.  
• Length: 130 cm.

Cinturón de goma con hebilla de nailon.  
• Longitud: 130 cm.

COD. 198

## DIVING BELT CINTURÓN DE BUCEO

MADE IN ITALY



Length 140 cm.

Longitud de 140 cm.

	MATERIAL	INOX	NYLON
	BLACK/BLUE	191NB	192NB
	BLACK/SILVER	191NS	192NS

## NYLON/INOX BUCKLE HEBILLA EN INOX Y NAILON

MADE IN ITALY



Universal buckles in stainless steel or nylon.

Hebillas universales en acero inoxidable y nailon.

MATERIAL	INOX	NYLON
COD.	191/B	192/B

**WEIGHTS  
PLOMOS DE LASTRE**

MADE IN ITALY



WEIGHT   PESO	1 kg	2 kg
COD.	182	183

**STANDARD**



Mesh with adjustable belt to be worn around the waist.  
Dimensions: 50x40 cm.

Malla con cinturón ajustable para llevarse alrededor de la cintura.  
Dimensiones: 50 x 40 cm.

COD. 246/BP
-------------

**STANDARD MESH BAG  
BOLSA MALLA ESTÁNDAR**



Mesh bag 60x20 cm.

Bolsa de malla polivalente 60x20 cm.

COD. 247/B
------------

**LUX**

**LUX MESH BAG  
BOLSA DE MALLA LUX**



Mesh bag with adjustable strap and wetsuit guard.  
Dimensions: 50x40 cm.

Bolsa de malla con correa ajustable y compartimento para llevar el traje húmedo. Dimensiones: 50 x 40 cm.

COD. 246/LP
-------------



Mesh bag with handle and reinforced net. 60x30 cm.

Bolsa de malla polivalente con asa y red de refuerzo. 60x30 cm.

COD. 247
----------

**SINGLE LINE + LINE LOCK | MONOLÍNEA + SISTEMA DE BLOQUEO DE LÍNEA**



NEW COLOR

- White 5 m (1.4 mm) + 3 sleeve.
- Black 5 m (1.7 mm) + 3 sleeve.

- Blanco 5 m (1.4 mm) + 3 sistemas de bloqueo de línea.
- Negro 5 m (1.7 mm) + 3 sistemas de bloqueo de línea.

MODEL	WHITE   BLANCO 5 m	BLACK   NEGRO 5 m
COD.	S311125	125-298

**LINE LOCK FOR SINGLE LINE**  
**SISTEMAS DE BLOQUEO DE LÍNEA**  
**POR MONOLÍNEA**

**NEW**



20 pieces/unit  
20 unidades/código

COD. 111-106

**FISH STRINGER CABLE**  
**CABLE PORTAPECES**

   
MADE IN ITALY



COD. 243

**HARPOON LOADER**  
**CARGADOR DE TRIDENTE**

   
MADE IN ITALY



COD. 162

**CHARGEUR UNIVERSEL**  
**UNIVERSALLADER**

   
MADE IN ITALY



COD. 174

**PRONG GUARD FOR HARPOONS**  
**PROTECTOR DE PUNTAS PARA TRIDENTES**

   
MADE IN ITALY



COD.	171/B	171/D	171	171/C
NUMBER OF HEAVY PRONGS NÚM. DE PUNTAS PESADAS	3	5	-	-
NUMBER OF LIGHT PRONGS NÚM. DE PUNTAS LIVIANAS	-	-	3	5

**SHAFT KIT**  
**KIT PARA FLECHAS**

   
MADE IN ITALY



Package of spring, line guide, Ø 7 mm ring and Ø 8 mm stainless ring.

Paquete de muelles, sistema de guías para línea de disparo, anilla de 7 mm de diámetro y anilla de acero inoxidable de 8 mm de diámetro.

DIAMETER   DIÁMETRO	7 mm	8 mm
COD.	250/7	250/B8



### DYNEEMA

MADE IN ITALY



Ø 1 mm - 120 kg - 50 m - BLACK  
 Ø 2 mm - 250 kg - 50 m - WHITE

100% Dyneema. Maximum resistance to abrasion and wear.  
 100 % Dyneema. Resistencia máxima a la abrasión y el desgaste.

DIAMETER   DIÁMETRO	1 mm	2 mm
COD.	1603	1604

### DYNEEMA

MADE IN ITALY



Ø 1.1 mm WAXED WHITE - 50 m  
 Ø 1.4 mm RED 100% - 50 m  
 Ø 1.8 mm BLACK FOR WISHBONES - 50 m

BLANCA de 1.1 mm de diámetro - 50 m  
 100% ROJA de 1.4 mm de diámetro - 50 m  
 NEGRA PARA OBÚS, de 1.8 mm de diámetro - 50 m

DIAMETER   DIÁMETRO	1.1 mm	1.4 mm	1.8 mm
LENGTH   LONGITUD	50 m	50 m	50 m
COD.	111-107	111-108	111-109

### INSERCIONES PARA OJIVA WISHBONE INSERTS



Pair of inserts for Dyneema wishbone.  
 Copia de las inserciones para ojiva en Dyneema.

COD. 1250001
--------------

### SHAFT STRAIGHTENER ENDEREZADOR DE VARILLAS DE FLECHA



Stainless steel tool designed to grasp the end of the shaft for disengaging effectively.  
 Also helpful for straightening shafts of different diameters.

Herramienta de acero inoxidable diseñada para sujetar la punta de la flecha y desengancharla de una manera efectiva. También útil para enderezar arpones de diferentes diámetros.

COD. 1607
-----------

### LATEX BUNGEE



COD. 270505

COD. 125-297

Handy for easily hooking line to the line releaser.  
 Práctico para unir con facilidad la línea al liberador de línea.

VERSION	METAL	ROPE   CUERDA
COD.	270505	125-297

### RAFFI

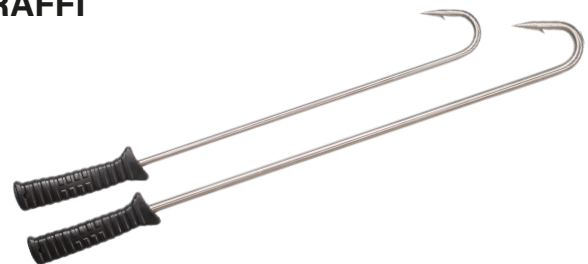

Ergonomic grip (with hole for possible use with a line), conical prong with barb.  
 Material: 304 stainless steel.

Empuñadura ergonómica (con orificio para un posible uso con una línea), punta cónica con rebaba.  
 Material: acero inoxidable 304.

LENGTH   LONGITUD	47 cm	57 cm
DIAMETER   DIÁMETRO	6 mm	8 mm
COD.	1605	1606

## Merchandising | Artículos publicitarios

Passion for the sea, having fun in complete safety, and a relentless search for high quality. Live the SEAC® style with the new line of accessories for your store! Displays, cardboard cutouts, and T-shirts to expertly promote your products, and spread the message "Keep calm and dive SEAC®".

Pasión por el mar, la diversión completamente segura y la búsqueda incesante de la alta calidad. ¡Viva el estilo SEAC® con la nueva línea de accesorios para su tienda! Exhibidores, figuras de cartón y camisetas para promocionar de manera experta sus productos, y difundir el mensaje: "Keep calm and dive SEAC®".



## DISPLAY

Metal display for products  
100x190x50 cm.

Exhibidor de metal para productos.  
100x190x50 cm.

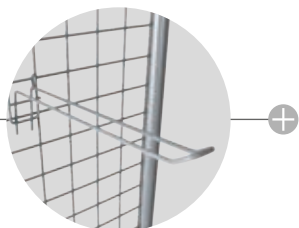

Including a 20 pack of 30 cm hooks.  
Incluye 20 piezas de ganchos de 30 cm.

COD. 9350

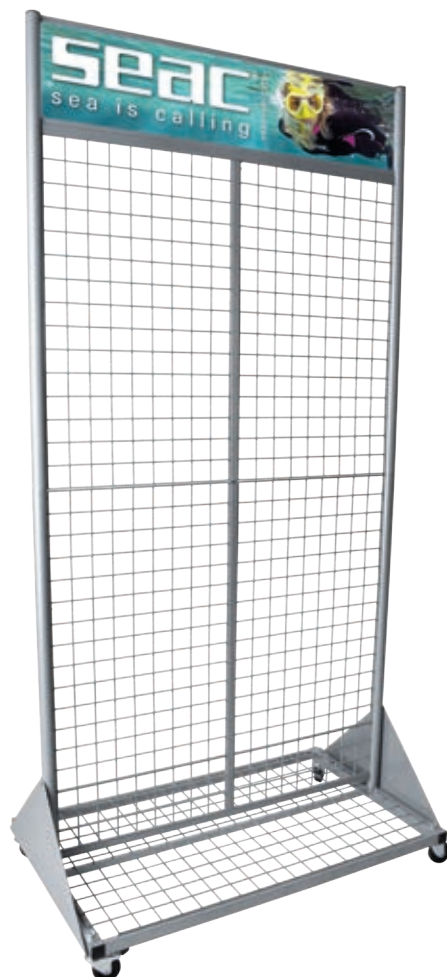
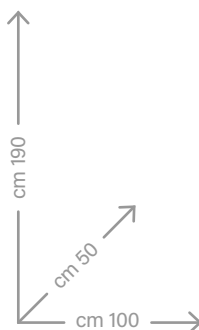

## BEACH FLAG

Beach flag, complete with 280 cm telescopic pole, cross base, waterbag and transport bag, with double curved flag in 100% nautical polyester of 55x200 cm.

Bandera de playa, completa con poste telescópico de 280 cm, base cruzada, bolsa de agua y bolsa para transporte, con bandera curvada doble hecha en poliéster 100% náutico de 55x200 cm.

COD. 300-2B/S





### BIO GEL DISPLAY EXHIBIDOR DE BIO GEL



COD. 300-15

### COMPUTER DISPLAY EXHIBIDOR DE ORDENADORES



Clear plexiglass display for watch computers. Includes parts for mounting to slot wall. Dimensions: 12.5x20x15.5 cm.

Exhibidor transparente de plexiglass para ordenadores de buceo. Incluye partes para montar a la pared. Dimensiones: 12,5x20x15,5 cm.

COD. 300-8

### FULL-MASK DISPLAY



Clear plexiglass display for full-face masks. Includes parts for mounting to slot wall. Dimensions: 15 x 31 x 19 cm.

Exhibidor transparente de plexiglass para máscaras completas. Incluye partes para montar a la pared. Dimensiones: 15 x 31 x 19 cm.

COD. 300-5



# CARDBOARD CUTOUT FIGURAS DE CARTÓN



COD. SCUBA - 300-3/XL

COD. SNORKELING - 300-4/XL

T-SHIRT SEAC®



SIZE   TALLA	XS	S	M	L	XL	XXL	XXXL
TURQUOISE	300-12AZ/XS	300-12AZ/S	300-12AZ/M	300-12AZ/L	300-12AZ/XL	300-12AZ/XXL	300-12AZ/XXXL
BLUE NAVY	300-12B/XS	300-12B/S	300-12B/M	300-12B/L	300-12B/XL	300-12B/XXL	300-12B/XXXL
GREY	-	300-12G/S	300-12G/M	300-12G/L	300-12G/XL	300-12G/XXL	300-12G/XXXL
GREEN	-	300-12V/S	300-12V/M	300-12V/L	300-12V/XL	300-12V/XXL	300-12V/XXXL







# ABISSI

Photo by Rizzo/Corradi

[www.bissonvini.it](http://www.bissonvini.it)



[www.seacsub.com](http://www.seacsub.com)



*Seac® sostiene chi ama il mare e lavora con passione.  
Da questo, nasce la collaborazione tecnica con l'azienda agricola Bisson per la maturazione subacquea dello spumante Abissi.*

*Seac® supports people who love the sea and who work passionately.  
That's why we're part of a technical collaboration with the Bisson vineyards to age Abissi sparkling wine underwater.*

official partner

**seac**<sup>®</sup>  
sea is calling



# SAFE FOR SEAC®

*Vivere il mare nel rispetto dell'ambiente e in totale sicurezza. Da qui nasce la nuova partnership tra SEAC® e SAFE, la prima azienda italiana interamente dedicata al mondo dei SUP gonfiabili diretta da Alessandro Onofri e Daniele Cimatti. Ma cos'è il SUP? Il SUP (Stand Up Paddle) è una tavola gonfiabile per le acque libere dai molteplici utilizzi: surf, race o leisure perfetta per raggiungere gli spot più belli dove fare snorkeling o apnea. Il SUP è semplice da utilizzare, alla portata di tutti e permette di trasportare con facilità la propria attrezzatura. Inoltre, è a impatto zero e questo è uno dei punti cardine che caratterizza questa collaborazione tra SAFE e SEAC®, sempre attenta alla tematica dell'imprescindibile rapporto di rispetto tra uomo e il mare. Oltre all'aspetto ambientale, la collaborazione tra le due aziende pone l'accento anche sulla sicurezza in acque libere. Per SEAC® "conoscenza del mare" vuol dire anche autoconsapevolezza e attenzione al proprio benessere e a quello dei compagni. Il SUP può diventare così sia un mezzo per raggiungere il luogo di immersione senza fatica, ottimizzando le proprie energie, sia un punto d'appoggio sicuro, dall'ampia superficie piatta, fondamentale in caso di stanchezza o malessere. Nace così il primo SUP con inedita livrea SEAC® prodotto della casa SAFE, basato sul modello Adventure 11'6" da 350x84 cm, perfetto per una navigazione sicura e veloce.*

*Living the sea while respecting the environment in total safety is premise from which it start the new partnership between SEAC® and SAFE, the first Italian company entirely dedicated to the world of inflatable SUPs directed by Alessandro Onofri and Daniele Cimatti. But what is a SUP? SUP (Stand Up Paddle) is an inflatable board for open water with multiple uses: surfing, racing or leisure perfect for reaching the most beautiful spots for snorkelling or free diving. The SUP is easy to use, within everyone's reach and allows you to easily transport all your equipment. Furthermore, it has zero impact, this is one of the key points that characterizes this partnership between SAFE and SEAC®, always attentive to the issue of the indispensable relationship between man and the sea. In addition to the environmental aspect, the partnership between the two companies also puts the emphasis on safety in open waters. For SEAC® "knowledge of the sea" also means self-awareness and attention to one's own well-being and that of team members. The SUP can thus become both a means to reach the place of immersion without effort, optimizing energies and with a large flat surface it can offer a secure support point, essential in case of tiredness or discomfort. The first SUP with the inedit (new) SEAC® livery is born, produced by SAFE, developed on the Adventure 11'6" 350x84 cm model, perfect for safe and fast navigation.*

[www.safewaterman.com](http://www.safewaterman.com)







scuba | snorkeling | freediving | 2020

### Headquarter

SEACSUB S.p.a.

Via D. Norero, 29

San Colombano Certenoli

(GE) 16040

Italy

Phone +39 0185 356301

Fax +39 0185 356300

seacsub@seacsub.com

### U.S.A. Branch

SEAC USA Corp.

7855 NW 12th Street, Suite 219

Miami, FL 33126

USA

Phone +1 786 580 3695

seac.usa@seacusa.com



seacsub.com